

# rotork<sup>®</sup>

Keeping the World Flowing  
for Future Generations

## K-TORK Range

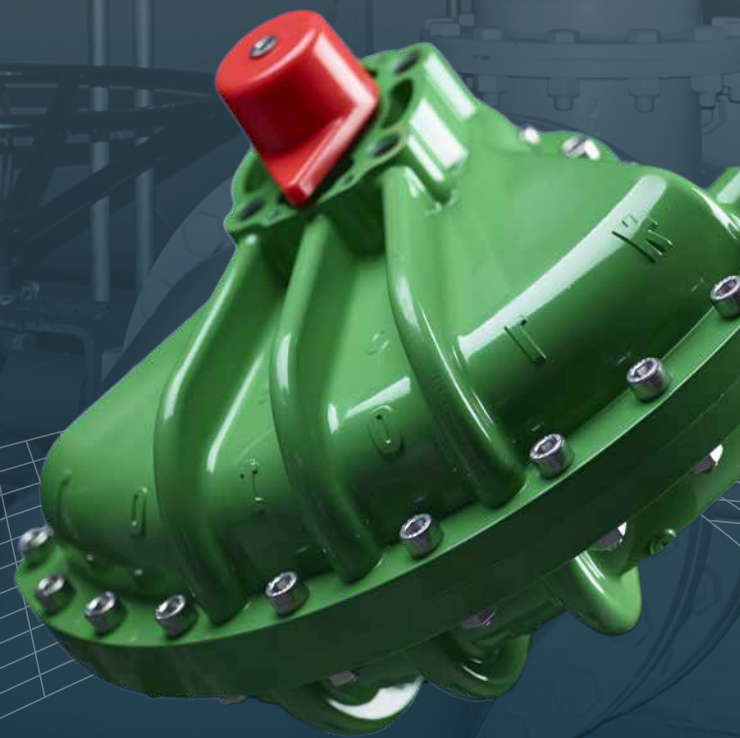

High-performance quarter-turn / rotary  
pneumatic actuators

## Reliability in critical flow control applications

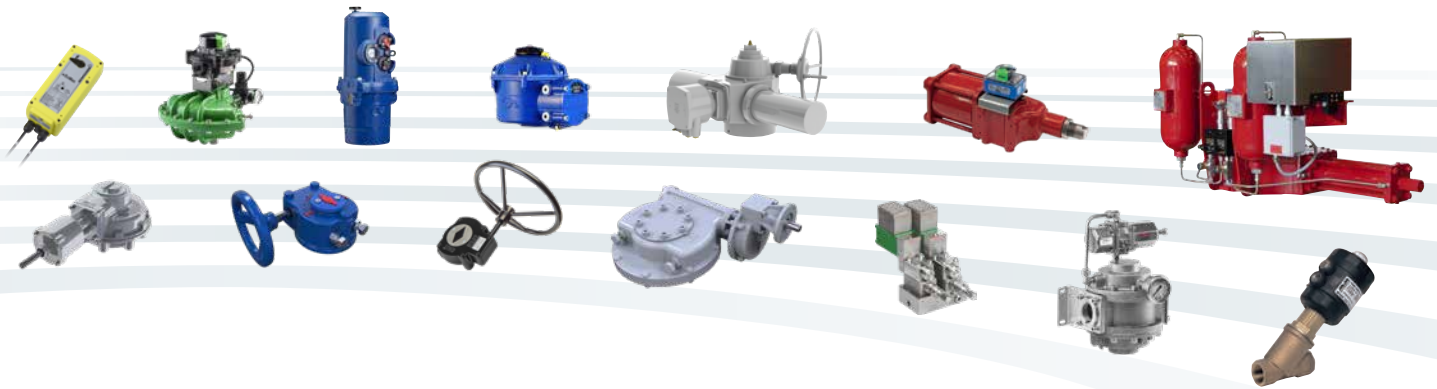

### › **Reliable operation** when it matters

Assured reliability for critical applications and environments. Whether used 24/7 or infrequently, Rotork products will operate reliably and efficiently when called upon.

### › **Quality-driven** global manufacturing

Products designed with 60 years of industry and application knowledge. Research and development across all our facilities ensures cutting edge products are available for every application.

### › **Customer-focused service** worldwide support

Solving customer challenges and developing new solutions. From initial enquiry through to product installation, long-term after-sales care and Client Support Programmes (CSP).

### › **Low cost** of ownership

Long-term reliability prolongs service life. Rotork helps to reduce long term cost of ownership and provides greater efficiency to process and plant.

# K-TORK Range

Section	Page	Section	Page
Rotork	2	Control Systems	11
Introduction	4	Specification and Certification	12
Product Overview	6	Materials of Construction	13
Modular Design	7	Industrial Applications	14
Design Features and Benefits	8	Municipal Applications	15
Double-Acting Actuators	8	Performance Data	16
Spring-Return Actuators	9	Model Number Designation	18
Factory Options	10	Rotork Site Services	19



## Comprehensive product range serving multiple industries

Improved efficiency, assured safety and environmental protection.

Rotork products and services are used throughout industry inclusive of Power, Oil & Gas, Water & Wastewater, HVAC, Marine, Mining, Pulp & Paper, Food & Beverage, Pharmaceutical and Chemical industries around the world.

## Global presence local service

Global company with local support.

Manufacturing sites, service centres, sales offices and *Centres of Excellence* throughout the world provide unrivalled customer services and fast delivery.

## Market leader technical innovator

The recognised market leader for 60 years.

Our customers have relied upon Rotork for innovative solutions to safely manage the flow of liquids, gases and powders.

## Corporate social responsibility

A responsible business leads to being the best business.

We are socially, ethically, environmentally responsible and committed to embedding CSR across all our processes and ways of working.

## Introduction

This brochure provides a comprehensive overview of the applications and associated functions available with K-TORK vane actuators. The vane actuator is a true rotary actuator that does not require the conversion of linear to rotary motion. The actuator is a very simple, highly accurate and reliable quarter-turn / rotary actuator.

K-TORK actuators are available in both double-acting and spring-return configurations. They are used to operate ball, butterfly or plug valves as well as many other mechanisms that require a 90° rotation. K-TORK actuators are used in a variety of industries on many applications.

Our involvement can go further than just providing the actuator; we can also supply valve adaption kits and control systems. Well equipped Rotork trained engineers, technicians and representatives provide worldwide on-site and factory based service. In addition, specialist Rotork Site Services teams offer preventative maintenance, retrofit and client support services.



### Industries

- Refining
- Water Treatment
- Wastewater Treatment
- Petrochemical
- Oil & Gas
- Desalination and RO
- Brewery & Winery
- HVAC
- Pulp & Paper
- Power Generation
- OEM
- Glass Manufacturing
- Food & Beverage
- Pharmaceutical
- Cement & Lime
- Mining & Materials
- Mobile Equipment
- Steel & Aluminium

### Industry Compliance

- CE and ATEX
- CE, FM and CSA approved electrical components
- ANSI / AWWA #C-540-02 and #C-541-08 standards for hydraulic and pneumatic cylinder and vane type actuators
- NAMUR VDI / VDE 3845 accessory mount standards
- ISO 5211 drive dimension standards on all spring-return models

*Note: Dimension data cannot be adequately presented within this brochure. For detailed product drawings and other documentation visit our website [www.rotork.com/en/product/index/ktorkliterature](http://www.rotork.com/en/product/index/ktorkliterature)*





K-Tork actuators are used in many industries, on various quarter turn applications.

They provide high torque output, precise modulating accuracy and are particularly suited to high cycle applications.

## Product Overview

**With only one moving part, the K-TORK Range actuators provide a range of benefits:**

- Compact, space-saving design ideal for membrane or packaged plants, filter galleries and vaults
- Designed for high cycle and precise modulating services
- Linear and constant torque output
- Complete range of pneumatic, analogue and digital controls
- Fail-Close, Fail-Open or Last-Position upon power loss
- No high-voltage power or MCCs required
- Adjustable OPEN / CLOSE speed control
- 100% duty-cycle, immune to thermal overload
- Refined retrofit process to upgrade existing valves

### True Rotary Actuator

K-TORK actuators do not convert linear motion to rotary motion, there is no sideload transferred to the actuator housing or valve stem, resulting in true rotary control and increased life expectancy of butterfly, ball and plug valves.

### Compact / High Torque Output

K-TORK actuators provide high torque output in a small size. The vane actuator design is compact and centres the actuator over the valve, eliminating stress on the valve body and stem.

### Efficiency and Long Life

Unmatched service life is the result of the dual opposed lip seal design. The stainless steel expanders energise the lip seals to the housing for constant, leak free years of performance.

### Corrosion Resistant Finish

Durable polyester powder coat finish. Green standard colour: RAL 6018.

### Modulating Accuracy

The direct drive design of the K-TORK actuator reduces the lost motion or hysteresis, resulting in highly accurate modulating specifications of 0.25% or better. Additionally, the dual-opposed lip seals are low friction.

### Easy Accessory Mounting

Integral NAMUR dimensions conform to VDI/VDE 3845 for top mounted control accessories and NAMUR solenoid interface eliminates fittings and tubing from solenoid valve.

### Future-Proof Controls

K-TORK actuators will stand the test of time. As technology develops, the control system can be updated but the actuator will remain. Controls can be easily upgraded onto the same actuator over time.



### Asset Management / Cost of Ownership

Initial purchase price is only the first component to cost. K-TORK actuators will provide the lowest installed and life cycle cost in demanding Open / Close and Modulating applications. Reduced commissioning time, unplanned maintenance, downtime, routine maintenance, conduit and wiring, power consumption, and outside service costs.

### Safety

The K-TORK spring tension safety band allows for the safe installation or removal of the spring from the actuator. The spring fail direction can be changed from CW to CCW using the same spring, providing flexibility and reducing inventory levels.

### High-Cycle Design

The low friction polyurethane or high temperature seals in each actuator will provide years of trouble free operation. There are no pressure retaining o-ring seals in a K-TORK actuator as these are prone to leak, increase friction and lower service life.

### Modular Design

A spring can be added to double-acting actuators to make them spring-return actuators, reducing stock requirements.

### Spring-Return Reliability and Longevity

Spring is guaranteed for the life of the actuator.

### Spring-Return Balanced Torque Output

Spring tension adjusted to match actuator air supply, providing balanced air / spring torque output.

The low torque loss associated with K-TORK spring-return actuators can result in smaller actuator selection and associated cost savings.



# Modular Design

## The Best Modular Solution

K-TORK actuators are modular, versatile and available in both double-acting and spring-return configurations.

K-TORK actuators provide a simple, proven method to mount failsafe springs, manual overrides and control accessories. The components can be added or removed, serviced or upgraded while mounted to the valve.

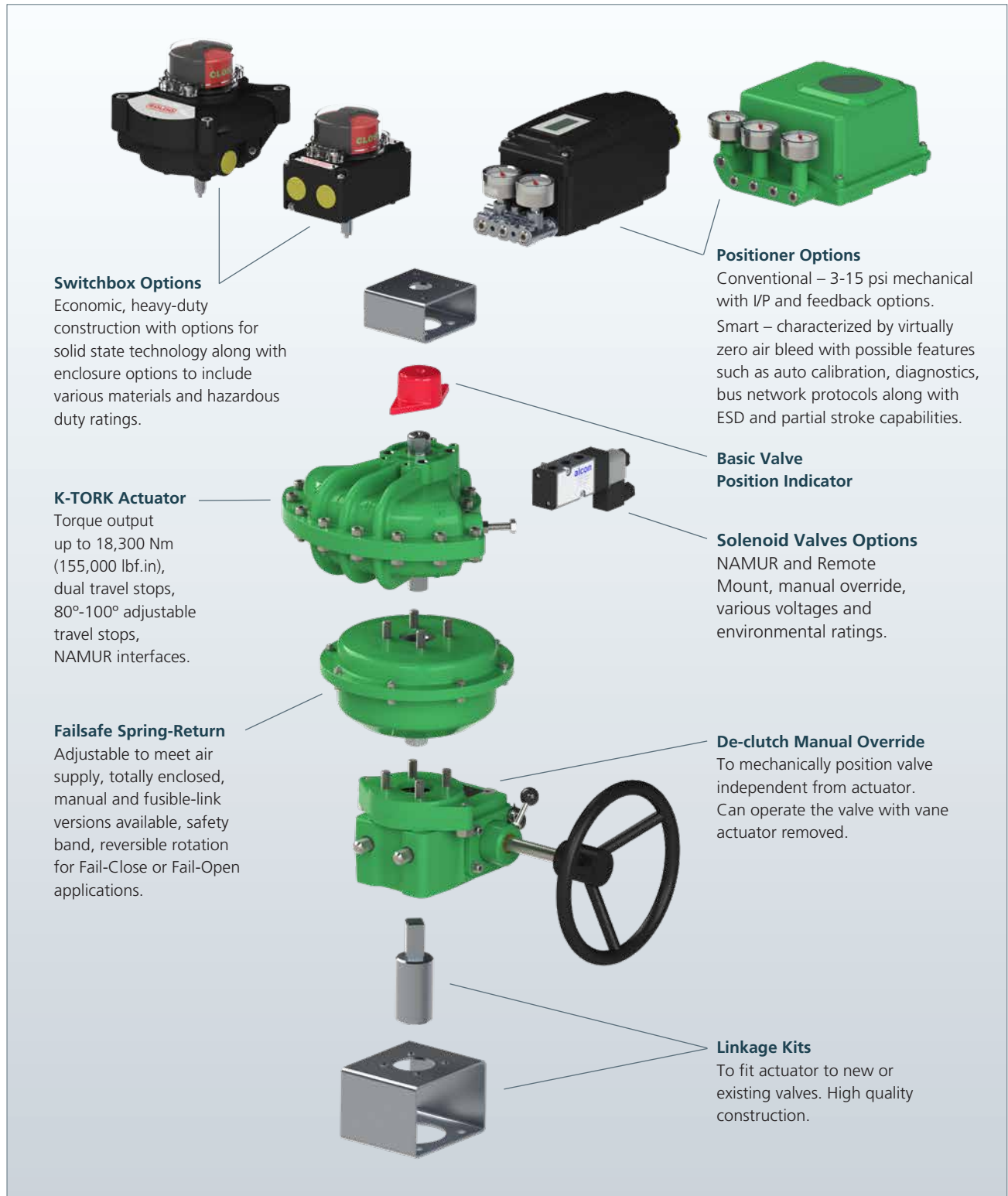

### Switchbox Options

Economic, heavy-duty construction with options for solid state technology along with enclosure options to include various materials and hazardous duty ratings.

### K-TORK Actuator

Torque output up to 18,300 Nm (155,000 lbf.in), dual travel stops, 80°-100° adjustable travel stops, NAMUR interfaces.

### Failsafe Spring-Return

Adjustable to meet air supply, totally enclosed, manual and fusible-link versions available, safety band, reversible rotation for Fail-Close or Fail-Open applications.

### Positioner Options

Conventional – 3-15 psi mechanical with I/P and feedback options.  
Smart – characterized by virtually zero air bleed with possible features such as auto calibration, diagnostics, bus network protocols along with ESD and partial stroke capabilities.

### Basic Valve Position Indicator

### Solenoid Valves Options

NAMUR and Remote Mount, manual override, various voltages and environmental ratings.

### De-clutch Manual Override

To mechanically position valve independent from actuator. Can operate the valve with vane actuator removed.

### Linkage Kits

To fit actuator to new or existing valves. High quality construction.

## Design Features and Benefits

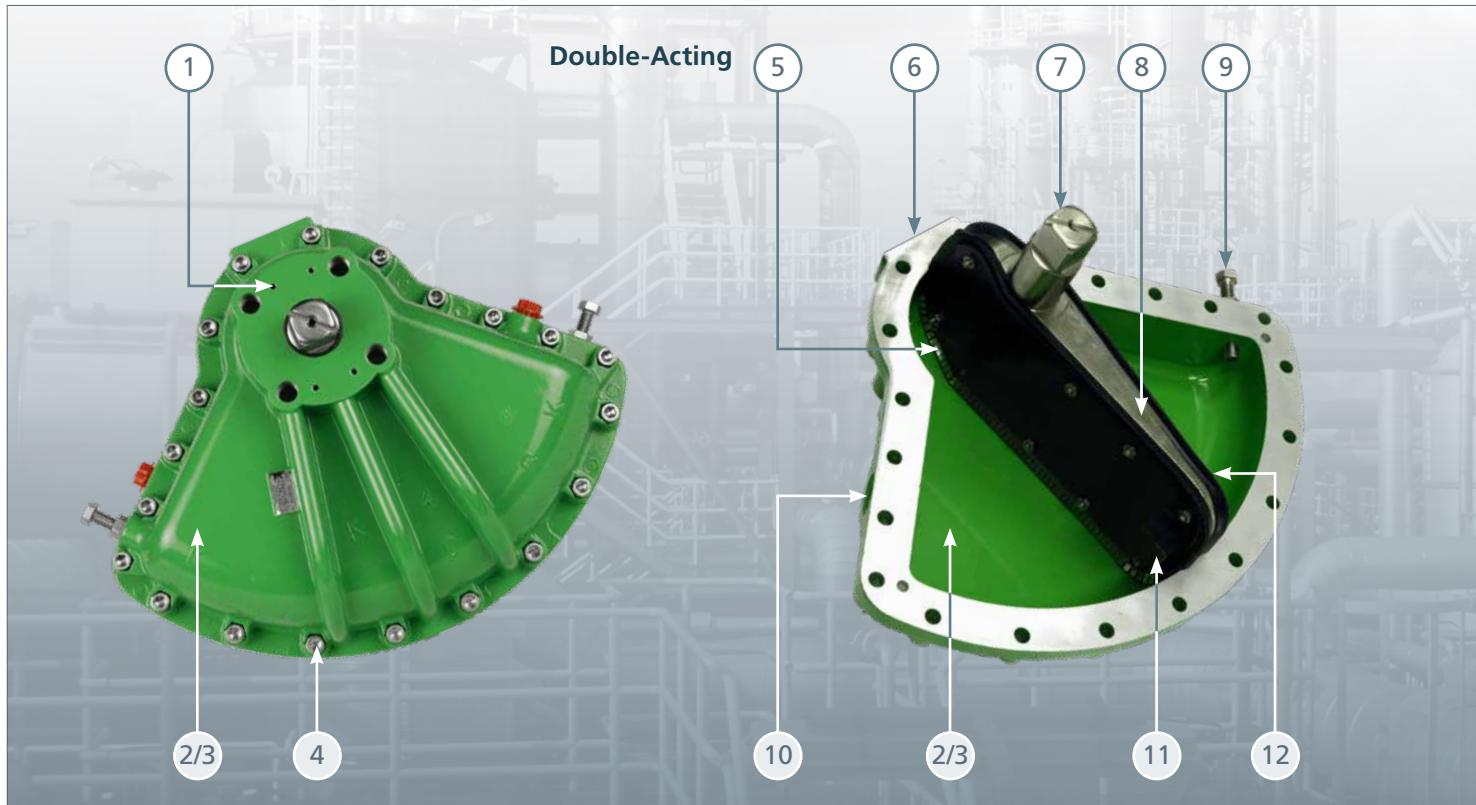

### 1 Integral Namur Accessory Mount

Meets VDI/DE 3845 accessory mount standards for positioners, limit switches and indicators.

### 2 Outer Cases

Made from lightweight, corrosion resistant aluminium alloy or zinc.

### 3 Interior / Exterior Finish

Durable corrosion resistant TGIC polyester epoxy powder coat finish, inside and out. Optional RANGER CG coating for highly corrosive environments.

### 4 Fixings

Stainless steel for long term corrosion resistance.

### 5 Vane Seal Expander

Ensures long term lip seal-to-case contact. Excellent in both high cycle and low cycle applications. See enlarged detail view.

### 6 Integral Namur Manifold

For direct mount solenoid valve, eliminates fittings and tubing.

### 7 Alloy Steel Drive Shaft

High tensile output shafts for strength and durability, ENP finish for corrosion resistance. No pressure retaining seal as lip seals isolate output shafts from supply air. Round and square output options on top shaft. See Rotork website for details.

### 8 Integral Vane / Shaft Casting

Cast as a single piece; only one moving part. Eliminates all "slop" or hysteresis.

### 9 Bi-Directional Travel Stops

80° to 100° standard adjustments, extended travel stops available.

### 10 Large Air Inlet Port for Fast Operation

Provides for high cycle speed of operation with no restrictions.

### 11 Vane Seal Side-Plate Retainer

Provides the strength to assure accurate Open and Close stop positions.

### 12 Dual Opposed Lip Seals

Provides effective, air assisted seal for low friction and long, maintenance free life.



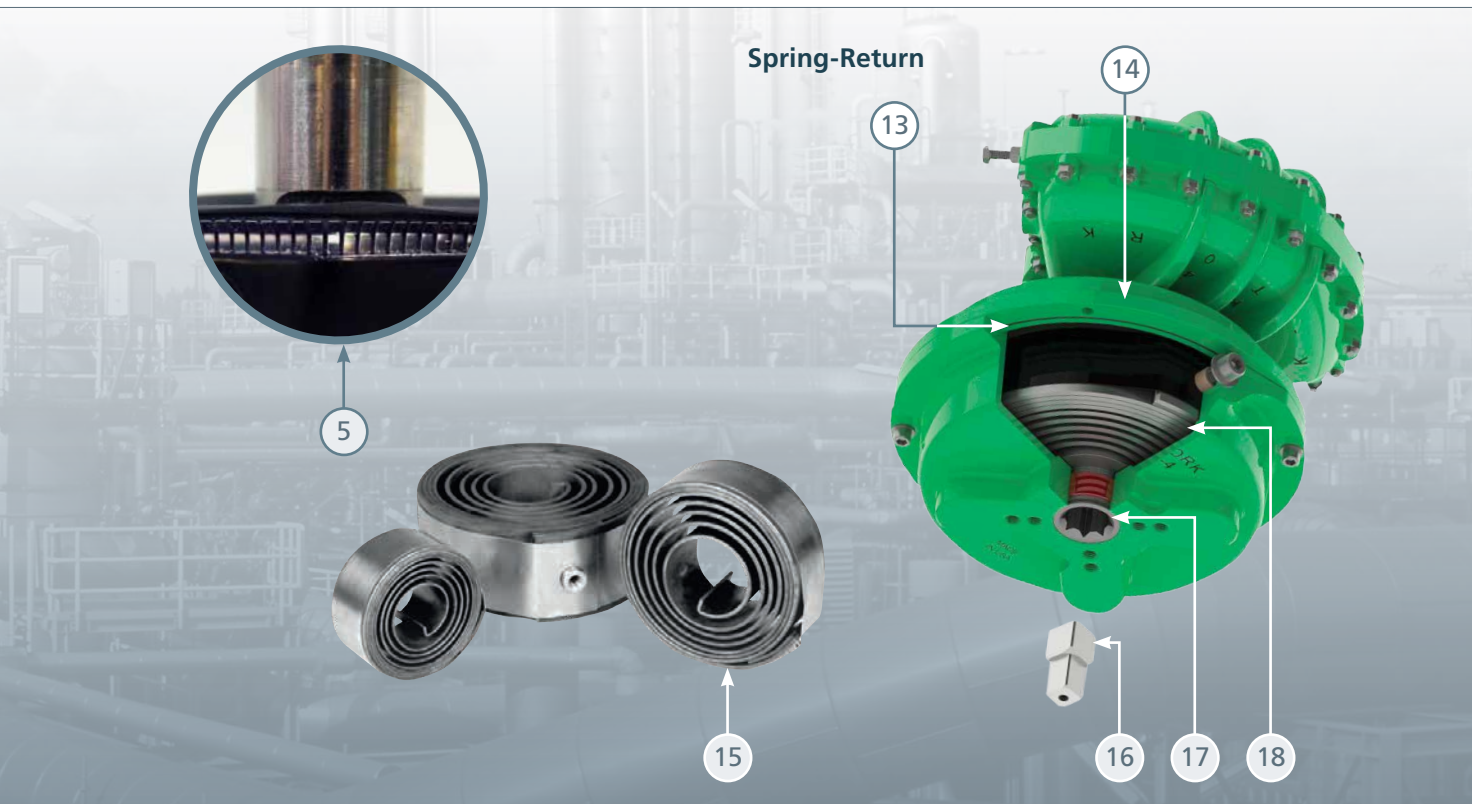

### 13 Totally Enclosed / O-Ring Sealed

Non-breathing spring is protected externally from environmental corrosion and internally from supply air and atmospheric air contaminants. Eliminates the need for re-breather systems.

### 14 Low Torque Loss

Low stress clock spring limits torque loss to approximately 20% through 90° stroke.

### 15 Safety

Spring includes a unique steel safety band around spring perimeter, allowing safe removal from housing.

### 16 Drive Insert

Optional male drive insert to match actuator drive shaft.

### 17 Dual Output Drive

Spring standard with ISO 5211 star pattern female drive and ISO mount flange coupled with matching actuator bolt circle.

### 18 Reversible Fail Direction

Spring may be removed from housing and flipped to reverse fail direction for flexibility, reducing stock requirements.



## Factory Options

### Manual Override Gearboxes

The K-TORK de-clutch gearbox manual override mounts between the actuator and the valve to provide for manual valve operation in the event of air failure.

- No additional mounting parts required. Can be easily added to any actuator
- Will lock and hold valve in any position
- Remains attached to valve when actuator is removed
- Vandal proof option for lock-out feature to ensure valve remains in position
- Dual, mechanical travel stops standard
- Cast iron housing, hardened steel worm and bronze sector gear for long service life
- Stainless steel input shaft
- AUTO MANUAL legend plate
- High temperature grease, permanently lubricated



### Air Failsafe Actuator

K-TORK Air Failsafe actuators incorporate an integral air accumulator to fail valve in desired position upon loss of air pressure, electrical power, or both.

- Economical alternative to large, heavy mechanical spring-return actuators
- Will not allow valve / actuator to “drift” during periods of low supply air pressure
- Easily field reversible to change fail position
- Capable of multiple valve cycles after loss of supply air



### RANGER CG Corrosion-Guard Finish

The RANGER CG finish greatly extends the life of actuators in highly corrosive environments. Housing and vane treated both inside and out while the RANGER CG system treats all internal threads and cavities.

### Applications and Installations

- Chemical and petrochemical plants
- Chlorine-rich environments
- Offshore and coastal environments
- Caustic washdown areas

The K-TORK RANGER CG actuators are designed to provide maximum protection in aggressive corrosive environments. It all starts with the K-TORK high performance rotary vane actuators. The cast aluminium body and alloy steel vane are treated with a thermosetting tripolymer resin coating system formulated for mechanical components requiring corrosion resistance and surface lubrication.

Once applied, the RANGER CG system provides an armoured layer of protection against a wide range of acids, caustics, solvents and salt-laden (coastal refining, offshore & desalination) environments. The RANGER CG system can be provided on all K-TORK actuator and spring-return models. Note that the K-TORK spring-return is totally sealed. The non-vented spring housing and spring are not subject to compressed air or atmospheric contaminants or moisture.



# Control Systems

## Bus Network Systems

K-TORK actuators can be supplied to interface with a variety of industry standard 2-wire or 4-wire bus network protocols that transfer both control & monitoring and power to each actuator.

These standardised communication networks and intelligent valve controls will reduce installation costs (wiring and conduit) and start-up expense, reduce I/O costs, reduce panel space and MCC requirements, reduce ongoing power consumption and enable valve and instrument diagnostics.



Modbus®



## Solenoid Valves

Solenoid valves can either be directly mounted via NAMUR interface or remotely mounted using a side ported style depending on size of the actuator and customer adapted standard.



## Limit Switches

Limit switch or bus network devices provide both valve position feedback and other diagnostic information to the control system. Units can attach to the top of the actuator via the NAMUR interface.



## Modulating – Digital Valve Positioners

Rotork supplies various digital valve positioners to suit customer needs. Digital positioners are used for precise modulating and control applications. These state of the art devices mount to the actuator via the NAMUR interface on all sizes. Designed for a wide variety of hostile environments and demanding applications, our digital positioners provide user friendly set-up and years of trouble free service.



## Modulating – Conventional Positioners

Rotork supplies various conventional positioners to suit customer needs. Conventional positioners are rugged, easy to calibrate and suitable for pneumatic or analogue input signals. The modular design provides for the simple addition of an integral I/P converter, mechanical or proximity limit switches, analogue output transmitter or Ohm potentiometer output transmitter, all inside the same enclosure.





# Specification and Certification

## General

K-TORK range actuators are designed for the pneumatic operation of valves, dampers and other mechanical devices that require a quarter-turn operation.

The actuator utilises a vane to provide a rotary motion and is available in double-acting and spring-return versions. The actuator can also be supplied with limit switches, positioner, and manual gearbox as required to suit the application.

## Valve Interface

K-TORK actuators are available with mounting flanges and output drive couplings conforming to international standard ISO 5211 or USA standard MSS SP-101.

## Easy Mounting of Accessories

NAMUR topworks mounting interface facilitates easy installation of industry standard switch box and positioner assemblies.

## Lubrication

K-TORK actuators are factory sealed and lubricated for life.

## Design Life

Actuators are designed for a minimum of two million operations.

## Finish

Actuators are finished in polyester powder coating, colour green RAL 6018.

## Finish Options:

- Colour Other colours may be specified.
- Ranger Corrosion Guard finish.
- Offshore Two-part epoxy coatings are available for extreme environmental conditions.

Please apply to Rotork for availability, cost and delivery implications of special finishes.

## Operating Temperature

K-TORK actuators are built with two seal options, referred to as high and low temperature builds, suitable for the following operating temperature ranges:-

**High Temperature (HT):** -20 to +149 °C (0 to +300 °F)

**Low Temperature (LT):** -40 to +70 °C (-40 to +160 °F)

Both build options are suitable for standard operating temperature ranges, -20 to +70 °C (0 to +160 °F). A specific build option is only required for low and high temperatures where the operating conditions are outside this range.

Please contact Rotork for further details, and to confirm operating temperature range at required design point.

## Operating Medium

Compressed air or inert gas.

## Operating Pressure

**Sizes KT-02 to KT-06:** 2 to 7 bar (30 to 100 psi) range, 7 bar (100 psi) maximum working pressure, 10 bar (150 psi) maximum overload pressure.

**Sizes KT-10 to KT-70:** 2 to 10 bar (30 to 150 psi) range, 10 bar (150 psi) maximum working pressure, 15 bar (220 psi) maximum overload pressure.

## Environmental Protection

Certified to IP66M / IP67M and meets NEMA 4 / 4X.

## Industry Standards

**Solenoid valve connection** NAMUR

**Fitting Accessories** VDI / VDE 3845, NAMUR

## Fitting to Valve:

- Standard actuator ISO adaptations available, otherwise standard output shafts as detailed on page 6.
- Spring-return Stardrive shaft with ISO 5211 mount flange with 90°, DIN with 45° and NAMUR. Optional male drive insert to match actuator drive shaft.

## International Standards

CE marked and certified in accordance with ATEX 94/9/EC.

## Accessories

A full range of limit switchboxes, positioners and other accessories are available to suit the application – all are available in general purpose or hazardous areas specifications to suit relevant requirements.

## Machinery Directive

K-TORK actuators as partly completed machinery must not be put into service until the machinery into which it is to be incorporated has been declared in conformity with the provisions of directive 2006/42/EC and the other relevant provisions.



## Materials of Construction

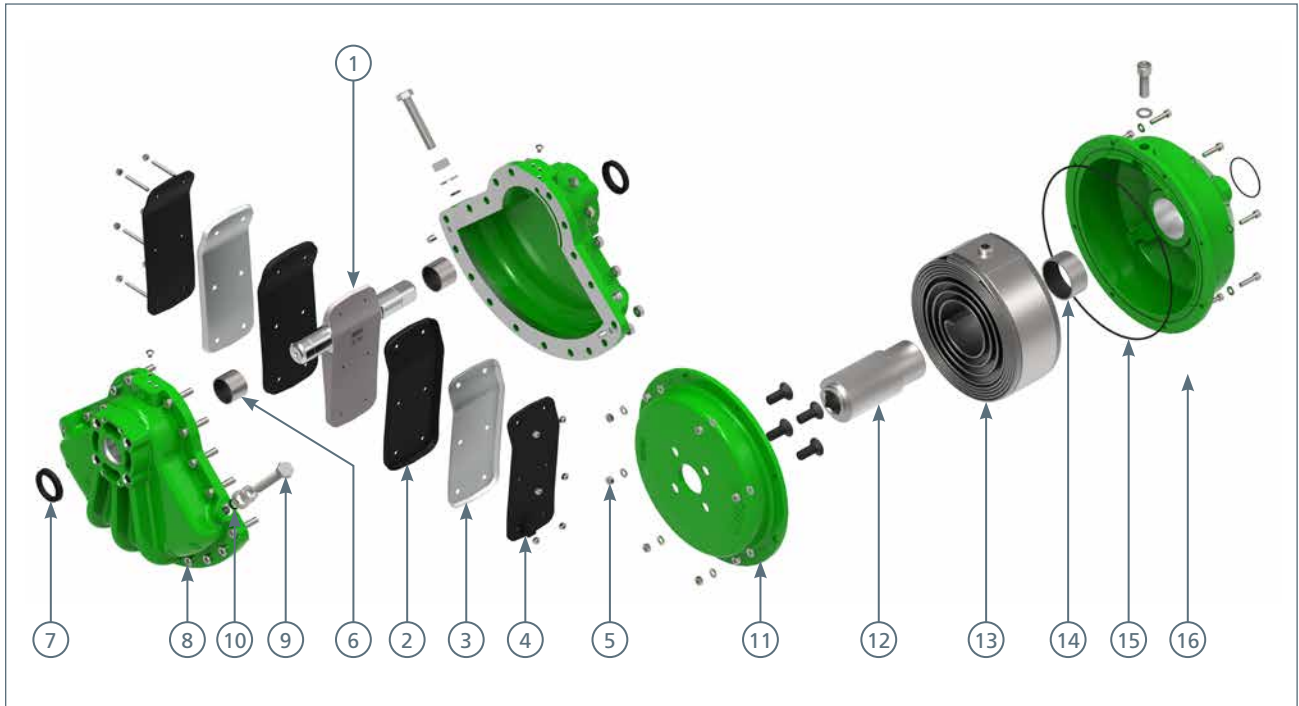

Exploded view of K-TORK range actuator and spring assembly.

### Materials of Construction for Double-Acting and Spring-Return Actuators

Item	QTY	Description	Material
1	1	Integral Vane / Shaft	ASTM A217 or 915 Cast Steel - Electroless Nickel Plated
2	2	Vane Seal	HNBR or polyurethane
3	2	Vane Seal Expander	304 Stainless Spring Steel
4	2	Vane Seal Side Plate Retainer	Carbon Steel - Epoxy Finish or polypropylene
5	-	Assembly Hardware	304 Stainless Steel
6	2	Shaft Bushing	Bronze Bushing - PTFE Lined, Steel Backed
7	2	Shaft Seal	HNBR
8	2	Outer Case	LM20 or LM25 Aluminium Alloy (A413 or A356A) or zinc
9	2	Stop Bolt	304 Stainless Steel
10	2	Stop Bolt O-Ring	Viton Rubber
11	1	Spring Housing Cover	A356A Aluminium Alloy
12	1	Spring Shaft	Steel - Electroless Nickel Plated
13	1	Spring	Carbon Steel
14	1	Shaft Bushing	Bronze Bushing - PTFE Lined, Steel Backed
15	1	Spring Housing O-Ring Seal	Viton Rubber
16	1	Spring Housing	A356A Aluminium Alloy
Note	-	Interior / Exterior Finish	Polyester Epoxy Powder Coating (Optional RANGER CG Coating Available)

Note: The KT-40 has two springs.

# Industrial Applications

## Demanding Industrial Applications

The K-TORK range of high performance actuators is well suited for the most demanding industrial applications. The K-TORK vane actuator is a true rotary actuator, which eliminates side-load, linkage arms, gears, cranks and pivot points.

Feature	Benefit
One moving part	Simple design / no lost production or downtime.
Dual-opposed lip seals	High cycle reliability, no o-rings to leak or wear out.
NAMUR interfaces	Standardised control accessory mounting.
Compact size	High torque output in a small package. Easy to handle and install.
High temperature option	Ideal for ambient environments up to +150 °C (+300 °F).
Modulating accuracy + no hysteresis	Replaces diaphragm actuators on quarter-turn control valves with no loss of performance.
Large air ports + no air restrictions	Capable of very fast cycle times.
Modular design	Easy to convert double-acting to spring-return; reduces stock.
Up to 150 psi (10 bar) working pressure rating on KT-10 and above	Reduce actuator cost and size if higher air pressure is available. Engineered safety margin.



## Industries and Associated Applications

### Power Generation

- Ash Handling
- Drains
- Feed Pump Isolation
- Feed Water Isolation
- Spray Control
- Turbine Bypass Systems and Drains

### Upstream Oil & Gas

- Compressor Recycle and Isolation
- Emergency Shut Down
- Fluid Injection
- LACT Skid
- Separator Skid Isolation

### Downstream Oil & Gas

- Catalytic Cracking
- Delayed Coking
- Hydrocracking

### Chemical Processing

- Ethylene Steam Vent
- Polyethylene High Cycle
- Polypropylene – UNIPOL
- Pressure Swing Absorption

### Pulp & Paper

- Boiler Vents and Drains
- Digester Steam Control
- Dryer Pressure Control
- Steam Supply Isolation



# Municipal Applications

## Optimising Valve Performance

K-TORK pneumatic actuators will operate butterfly, ball and plug valves in both basic OPEN / CLOSE service and in the most precise MODULATING applications. Our diverse range of valve controls has been designed to help you maximise the performance and reliability of your treatment and distribution systems.

K-TORK actuators will enhance productivity and lower operating expenses in applications such as:

### Water Treatment

- High Service and Low Service Pump Control
- Membrane and Ultra Filtration
- Conventional Filter Gallery
  - Influent
  - Effluent
  - Backwash Isolation and Control
  - Drain or Waste
  - Surface Wash
  - Air Scour
  - Filter to Waste
- Sludge Blowdown
- Raw Water Inlet

### Wastewater Treatment

- Tertiary Filters
- Reclamation Plants
- Blower Inlet / Outlet Isolation and Control
- Aeration Basin Isolation and Control
- Pump Control
- Ozone Control Valves
- Diverter Valves
- Gas Recovery Valves
- Solids Handling Valves
- Chemical Feed Valves
- Odour Control Valves
- Chlorine Valve Control

## The Retrofit Process and Ongoing Support

Upgrade the performance of existing valves with K-TORK and our refined retrofit process. A trained Rotork representative will complete a field survey to evaluate and measure for mounting parts, clearances, connections and operator interface.

3D CAD models will then be completed to assure proper fit and function, linkage kits will be fabricated by Rotork and installation services are available. No matter the age of your existing valve, Rotork can upgrade the performance and reliability with a new actuator that will interface with your SCADA or control system now and in the future.

## Industry Compliance

K-TORK actuators are fully compliant with:

- ANSI / AWWA #C-540-02 & #C-541-08 standards for hydraulic and pneumatic cylinder and vane type actuators
- CE, FM or CSA approved electrical components
- NAMUR VDI / VDE 3845 accessory mount standards
- ISO 5211 drive dimension standards on all spring-return models



## Performance Data - Double-Acting

### Double-Acting Torque Output: Nm

Model	Operating Pressure (bar)														
	3	3.5	4	4.5	5	5.5	6	6.5	7	7.5	8	8.5	9	9.5	10
KT-02	4.6	5.5	6.4	7.3	8.2	9.2	10	11	12	N/A	N/A	N/A	N/A	N/A	N/A
KT-03	10	12	13	15	17	19	21	23	25	N/A	N/A	N/A	N/A	N/A	N/A
KT-06	24	30	36	40	44	48	53	58	63	N/A	N/A	N/A	N/A	N/A	N/A
KT-10	47	56	65	75	84	94	104	114	123	132	141	149	157	167	176
KT-20	101	120	138	159	179	199	219	240	261	280	298	317	335	354	373
KT-30	231	273	315	359	402	445	488	530	572	613	654	695	736	777	818
KT-40	563	663	763	869	974	1,077	1,179	1,278	1,376	1,475	1,573	1,671	1,769	1,868	1,966
KT-50	1,308	1,533	1,757	1,980	2,203	2,429	2,654	2,876	3,097	3,318	3,539	3,760	3,981	4,203	4,424
KT-60	2,750	3,254	3,758	4,307	4,856	5,397	5,938	6,410	6,882	7,374	7,865	8,357	8,849	9,341	9,832
KT-70	5,900	6,900	7,900	9,000	10,100	11,125	12,150	13,175	14,200	15,300	16,400	17,350	18,300	N/A	N/A

### Double-Acting Metric Displaced Volume: cm<sup>3</sup>

Model	KT-02	KT-03	KT-06	KT-10	KT-20	KT-30	KT-40	KT-50	KT-60	KT-70
in <sup>3</sup>	31	69	175	348	721	1,720	4,084	8,393	18,887	37,774

Note: Volume of air required for (1) one 90° operation

### Double-Acting Torque Output: lbf.in

Model	Operating Pressure (psi)									
	40	50	60	70	80	90	100	125	150	
KT-02	36	48	59	70	82	93	105	N/A	N/A	
KT-03	84	110	136	162	188	214	240	N/A	N/A	
KT-06	196	255	313	372	431	488	547	N/A	N/A	
KT-10	384	492	600	720	840	960	1,080	1,344	1,620	
KT-20	816	1,044	1,272	1,524	1,776	2,016	2,280	2,844	3,420	
KT-30	1,860	2,400	2,892	3,432	3,960	4,476	4,992	6,240	7,488	
KT-40	4,548	5,796	6,996	8,292	9,600	10,800	12,000	15,000	18,000	
KT-50	10,596	13,392	16,092	18,792	21,600	24,300	27,000	33,744	40,500	
KT-60	22,200	28,296	34,500	41,292	48,000	54,492	60,000	75,000	90,000	
KT-70	47,500	60,000	73,000	86,500	100,000	111,500	125,000	155,000	N/A	

### Double-Acting Imperial Displaced Volume: in<sup>3</sup>

Model	KT-02	KT-03	KT-06	KT-10	KT-20	KT-30	KT-40	KT-50	KT-60	KT-70
in <sup>3</sup>	2	4	11	21	44	105	250	511	1,153	2,306

Note: Volume of air required for (1) one 90° operation

Please refer to [www.rotork.com](http://www.rotork.com) for latest product drawings and dimensional data.

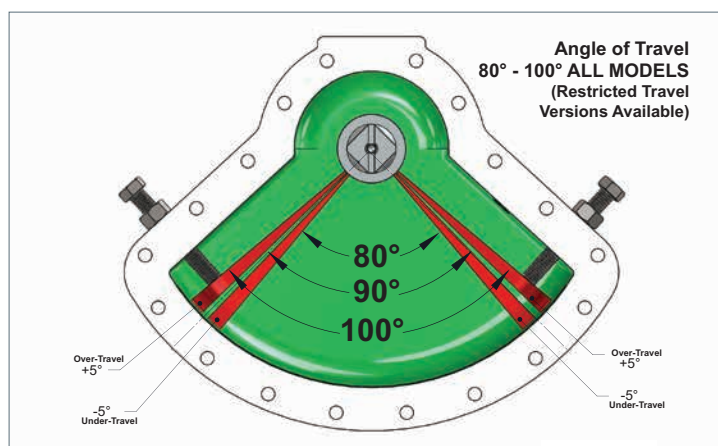

# Performance Data - Spring-Return

## Spring-Return Torque Output: Nm

Actuator Model	Air & Spring Torque	Operating Pressure (bar)				
		4.1	4.5	4.8	5.2	5.5
KT-03	Start	8	8	9	10	11
	End	6	7	7	8	8
KT-06	Start	15	17	18	20	21
	End	12	13	14	15	16
KT-10	Start	36	40	42	46	50
	End	29	33	37	39	46
KT-20	Start	78	84	89	96	104
	End	57	67	77	80	90
KT-30	Start	181	197	212	224	237
	End	141	157	169	186	202
KT-40	Start	403	445	472	502	502
	End	338	370	397	425	425

## Spring-Return Torque Output: lbf.in

Actuator Model	Air & Spring Torque	Operating Pressure (psi)				
		60	65	70	75	80
KT-03	Start	68	75	81	88	94
	End	53	59	63	69	73
KT-06	Start	135	147	160	173	185
	End	105	115	125	135	144
KT-10	Start	320	355	380	415	450
	End	255	300	330	350	410
KT-20	Start	690	750	790	850	920
	End	510	595	685	710	800
KT-30	Start	1,610	1,750	1,880	1,985	2,100
	End	1,250	1,390	1,500	1,650	1,790
KT-40	Start	3,563	3,943	4,180	4,446	4,446
	End	2,993	3,278	3,515	3,762	3,762

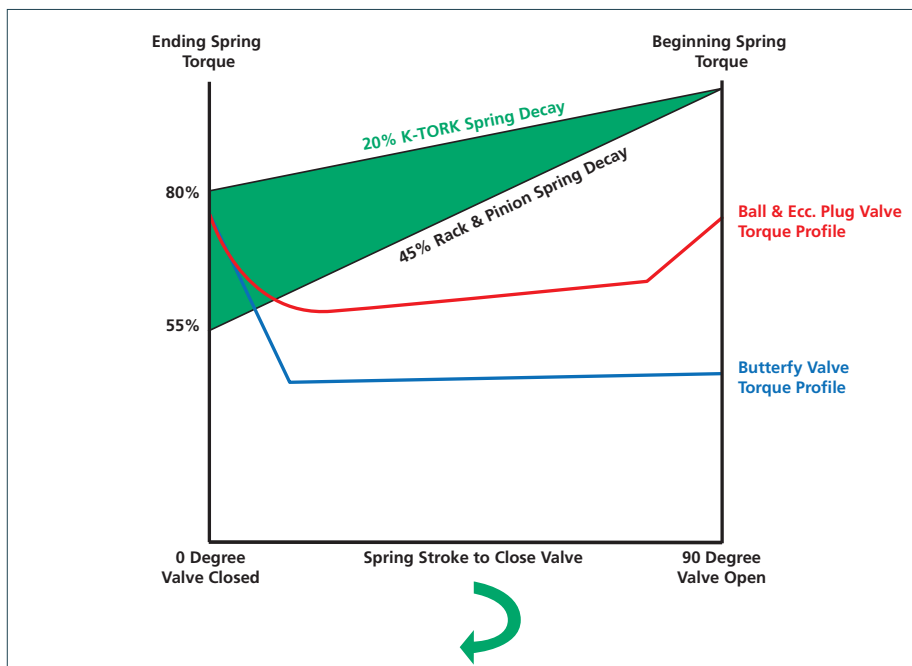



# Model Number Designation

Example Model Numbers	KT	-	30	-	FC 80	-	LT	-	M	-	EP	-	1
	KT	-	30	-	DA	-	HT	-	N	-	RG	-	0
<b>Actuator Type</b>													
KT = K-TORK vane													
<b>Actuator Size</b>													
02, 03, 06, 10, 20, 30, 40, 50, 60, 70													
<b>Effect</b>													
DA = Double-acting													
FC = Fail-to-Close (clockwise) <sup>1</sup>													
FO = Fail-to-Open (counter-clockwise) <sup>1</sup>													
<b>Spring Type</b>													
60, 65, 70, 75, 80													
Not applicable double-acting													
<b>Temperature</b>													
LT = Low temperature      -40 to +70 °C    (-40 to +160 °F)													
HT = High temperature     -20 to +149 °C   (0 to +300 °F)													
<b>Manual Override</b>													
M = De-clutch gear box													
N = None													
<b>Corrosion Resistance <sup>2</sup></b>													
EP = Standard finish, TGIC epoxy powder coat													
RG = RANGER CG - corrosion guard finish													
OS = Offshore painting													
<b>Version</b>													
0 = Imperial													
1 = Metric													

**Notes:**

1. Spring-return actuators factory set for 5.5 bar (80 psi) balance unless specified
2. All actuators standard with 304 stainless steel travel stops and fasteners
3. For standard temperature ranges (-20 to +70 °C, 0 to +160 °F) either version (LT or HT) can be used.

Please refer to [www.rotork.com](http://www.rotork.com) for latest product drawings and dimensional data.



## Projects, Services and Retrofit

# rotork® Site Services

In each of our divisions, Site Services staff are dedicated to providing customer service and support, carrying out new installations and delivering retrofit projects. These teams are based out of service centres around the world and are complemented by factory trained agents.

Our expert technicians support Rotork customers, allowing us to deliver on our promise of global solutions backed by local service.

**Visit [www.rotork.com](http://www.rotork.com) to identify your nearest Rotork location.**



### Client Support Programme

Rotork offers a premium level of product reliability and availability through the flexible Client Support Programme (CSP). Designed to facilitate the highest production demands while providing a tiered approach to maintenance, the CSP is committed to reducing maintenance downtime and costs.

Through consultation, the CSP is tuned to deliver the optimum level of maintenance through predictive maintenance algorithms.

#### Features of the CSP are:

- Fixed term prices for Rotork products and services
- Customisable cover based on equipment criticality to production
- Equipment performance related targets for reliability and availability
- Priority support with customisable response times
- Fully parts and labour inclusive, no additional costs or discounted labour and parts
- Fix or replace options
- Periodic equipment performance and status reports
- Built-in regular health checks on all equipment

#### Benefits of the CSP include but are not limited to:

- Year-on-year reduced maintenance costs
- Easy budget management
- Maximised production resulting in reduced downtime
- Year-on-year improved reliability and availability
- Optimised resource usage to accelerate in-house projects
- Reduced lifecycle costs



# rotork®

[www.rotork.com](http://www.rotork.com)

A full listing of our worldwide sales and service network is available on our website.

*UK*

Rotork plc

*tel* +44 (0)1225 733200

*fax* +44 (0)1225 333467

*email* [mail@rotork.com](mailto:mail@rotork.com)

*USA*

Rotork Dallas

*tel* +1 (214) 343-9980

*fax* +1 (214) 343-2658

*email* [ktork.info@rotork.com](mailto:ktork.info@rotork.com)

Rotork is a corporate member of the Institute of Asset Management



PUB097-001-00  
Issue 10/17

As part of a process of on-going product development, Rotork reserves the right to amend and change specifications without prior notice. Published data may be subject to change. For the very latest version release, visit our website at [www.rotork.com](http://www.rotork.com)

The names Rotork and K-TORK are registered trademarks. Rotork recognises all registered trademarks. Published and produced in the UK by Rotork. POWJB1019