

# FINE CONTROLS (UK) LTD



Fine Controls have been supplying process controls & instrumentation equipment since 1994, & now serves an ever expanding customer base, both in the UK & globally.

We offer a full range of valve & instrumentation products & services, with our product range representing leading technologies & brands:

**Flow:** Flow Meters & Transmitters, Flow Switches, Flow Control Valves & Batch Control Systems

**Temperature:** Temperature Probes & Thermowells, Temperature transmitters, Temperature Regulators & Temperature Displays

**Level:** Level Transmitters & Switches

**Pressure:** Pressure Gauges & Transmitters, Precision & High Pressure Regulators & I-P Converters, Volume boosters.

**Precision Pneumatics:** Pressure Regulators, I-P Converters, Volume Boosters, Vacuum Regulators

**Valves:** Solenoid & Pneumatic Valves, Control Valves & Positioners, Actuated Ball, Globe or Diaphragm Valves & Isolation Valves

**Services:** Repair, Calibration, Panel Build, System Design & Commissioning

A rotork® Brand  
**FAIRCHILD**



**bürkert**



**SIEMENS**



**alcon**  
SOLENOID VALVES

A rotork® Brand



**MIDLAND-ACS**  
A rotork® Brand



**Honeywell**



**Bourdon**  
Baumer Group



**SOLDO**  
CONTROLS

A rotork® Brand



Fine Controls (UK) LTD, Bassendale Road, Croft Business Park,  
Bromborough, Wirral, CH62 3QL UK  
Tel: 0151 343 9966  
Email: sales@finecontrols.com

## D15P

### Pressure reducing valve with balanced seat Standard pattern

#### Product specification sheet

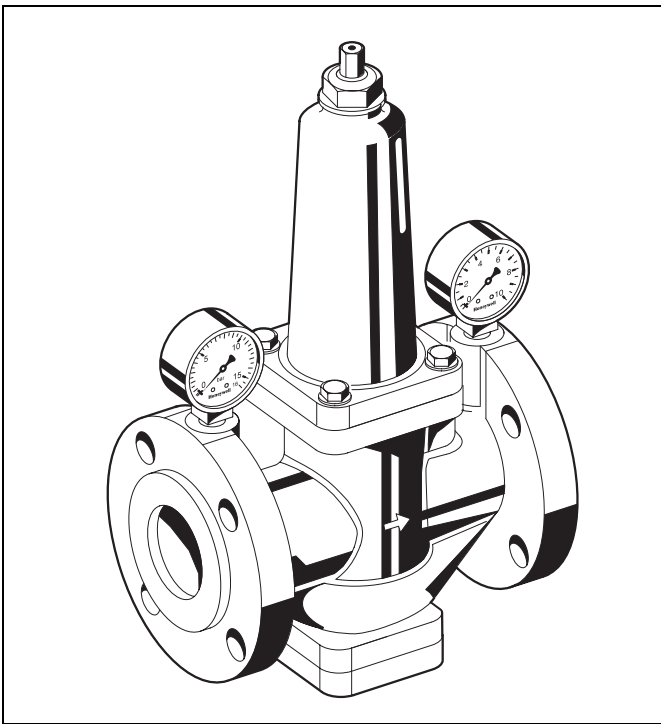

#### Construction

The pressure reducing valve comprises:

- Housing with PN16 flanges per ISO7005-2, EN1092-2
- Spring bonnet with adjustment screw
- Adjustment spring
- Valve system complete with diaphragm
- Pressure gauge

#### Materials

- Grey cast iron housing
- Cast iron spring bonnet
- Bronze valve seat
- Bronze piston guide
- Cone up to DN150: brass, DN200: steel
- Spring steel adjustment spring
- EPDM diaphragm
- NBR seal collar
- NBR seals
- Stainless steel screws and nuts

#### Application

Pressure reducing valves of this type protect installations against excessive pressure from the supply. They can be used for household, industrial or commercial applications within the range of their specification.

By installing a pressure reducing valve, pressurisation damage is avoided and water consumption is reduced.

The set pressure is also maintained constant, even when there is wide inlet pressure fluctuation.

Reduction of the operating pressure and maintaining it at a constant level minimizes flow noise in the installation.

#### Special Features

- Non-rising stem for setting outlet pressure and position indicator on spring bonnet (except for DN200)
- The adjustment spring is not in contact with the potable water
- With inlet and outlet pressure gauge (DN50-DN150) or with outlet pressure gauge (DN200)
- Inlet pressure balancing - fluctuating inlet pressure does not influence outlet pressure
- Powder coated inside and outside - Powder used is physiologically and toxicologically safe

#### Range of Application

Medium	Water, compressed air* and nitrogen* in consideration of valid standards (e.g. DIN EN 12502)
Inlet pressure	max. 16 bar
Outlet pressure	1.5 - 8 bar - DN50 - 150 1.5 - 6 bar - DN200

#### Technical Data

Operating temperature	max. 70°C
Nominal pressure	PN16
Minimum pressure drop	1.0 bar
Diaphragm pressure loading	max. 9.0 bar
Nominal size	DN50 - DN200

\* As part of an installation being approved according to PED requirements, this product must also be certified.

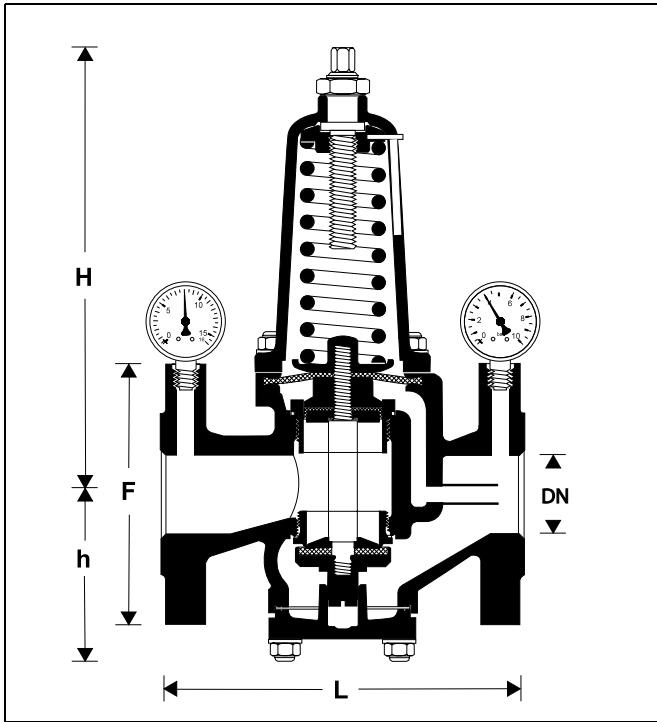

**Method of Operation**

Spring loaded pressure reducing valves operate by means of a force equalising system. The force of a diaphragm operates against the force of an adjustment spring. If the outlet pressure and therefore diaphragm force fall because water is drawn, the then greater force of the spring causes the valve to open. The outlet pressure then increases until the forces between the diaphragm and the spring are equal again.

The inlet pressure has no influence in either opening or closing of the valve. Because of this, inlet pressure fluctuation does not influence the outlet pressure, thus providing inlet pressure balancing.

**Options**

D15P-... A = With PN 16 flanged connections to ISO 7005-2, EN 1092-2 cast iron housing

Special Versions available on request  
 Connection size

Connection size	DN	50	65	80	100	125	150	200
Weight	kg	16.2	28.2	41.5	67	103	150	408
Dimensions	mm							
	L	230	290	310	350	400	480	600
	H	282	315	356	418	487	573	1200
	h	106	126	154	183	210	248	305
	F	165	185	200	220	250	285	340
k <sub>vs</sub> -value	m <sup>3</sup> /h	28	47	70	110	180	250	380

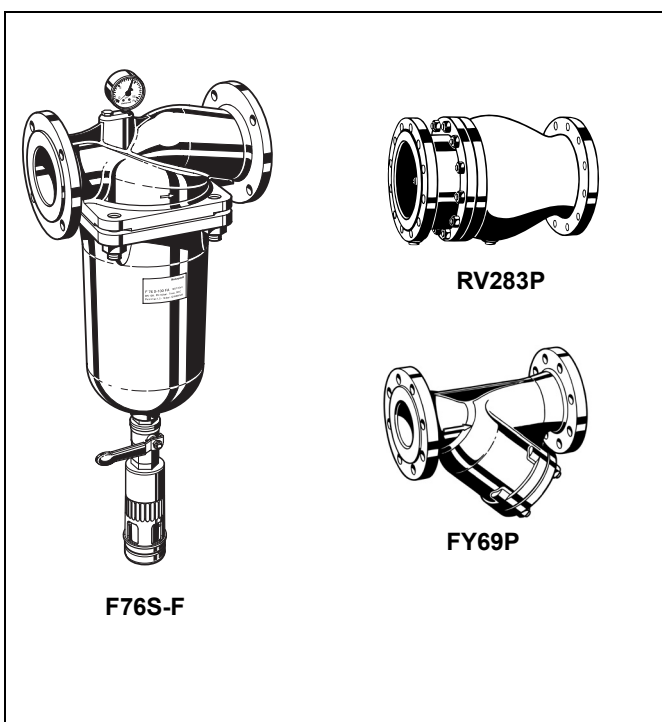

**Accessories**

**RV283P Check valve**

Grey cast iron housing, powder coated inside and outside. DIN/DVGW tested in compulsory test sizes DN 65, DN 80 and DN 100

**FY69P Strainer**

With double mesh, grey cast iron housing, powder coated inside and outside.

A = Mesh size approximately 0.5 mm

**F76S-F Reverse-rinsing filter**

Red bronze housing and filter bowl. Available in sizes DN 65 to DN 100, with filter mesh sizes 100 µm or 200 µm

**Installation Example**

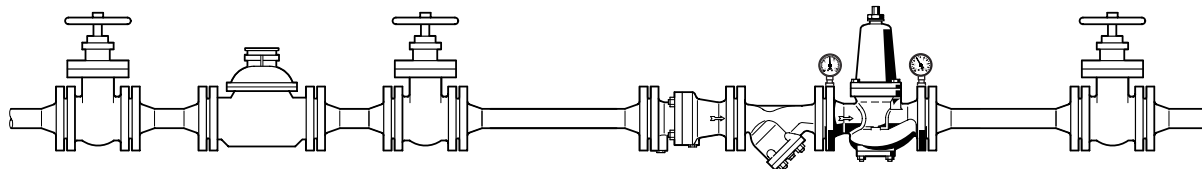

Connection size	DN	50	65	80	100	125	150	200
W*	mm	100	120	130	145	165	180	220

\* Minimum distance from wall to centre line of pipework

**Installation Guidelines**

- Install in horizontal pipework with spring bonnet directed upwards
- Install shutoff valves
- The installation location should be protected against frost and be easily accessible
  - o Pressure gauge can be read off easily
  - o Simplified maintenance and cleaning
- Install downstream of the filter or strainer
  - o This position ensures optimum protection for the pressure reducing valve against dirt
- Provide a straight section of pipework of at least five times the nominal valve size after the pressure reducing valve (in accordance with DIN 1988, Part 5)

**Typical Applications**

Pressure reducing valves of this type are suitable for multi dwelling buildings, industrial and commercial applications within the range of their specifications.

Pressure reducing valves should be installed:

- If the static pressure exceeds the maximum permissible value for the system
- If several pressure zones are required when a pressurisation system is used (pressure reducers on each storey of a building)
- If pressure fluctuations in the downstream system must be avoided
- To achieve constant inlet and outlet pressures on pumped pressure boosting systems
- To reduce the water consumption

**Flow Diagram**

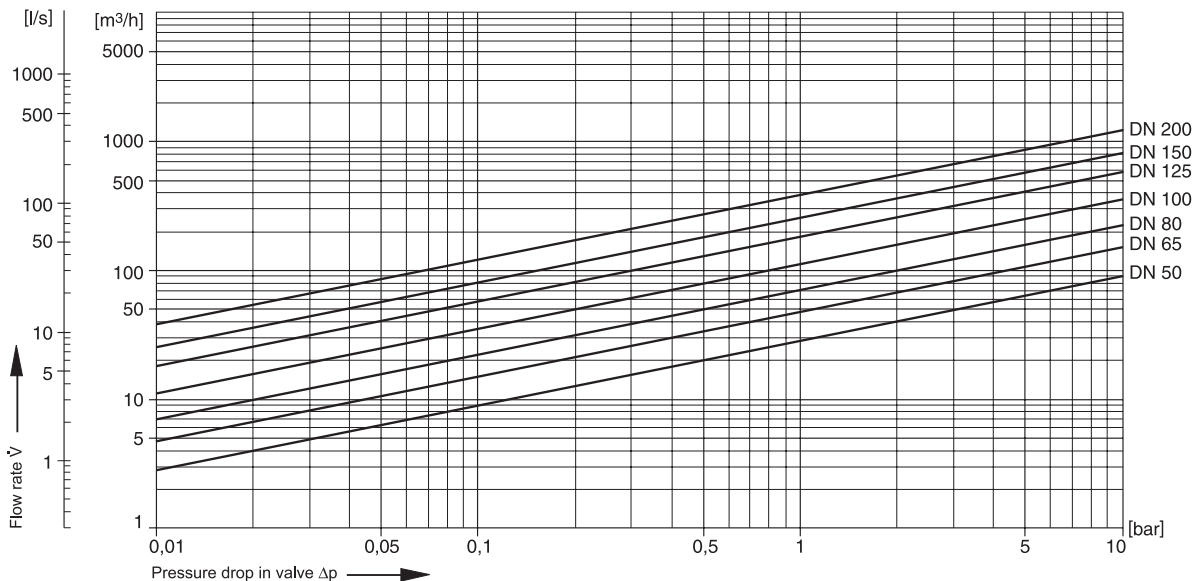

EN0H-1007GE23 R0307 • Subject to change without notice

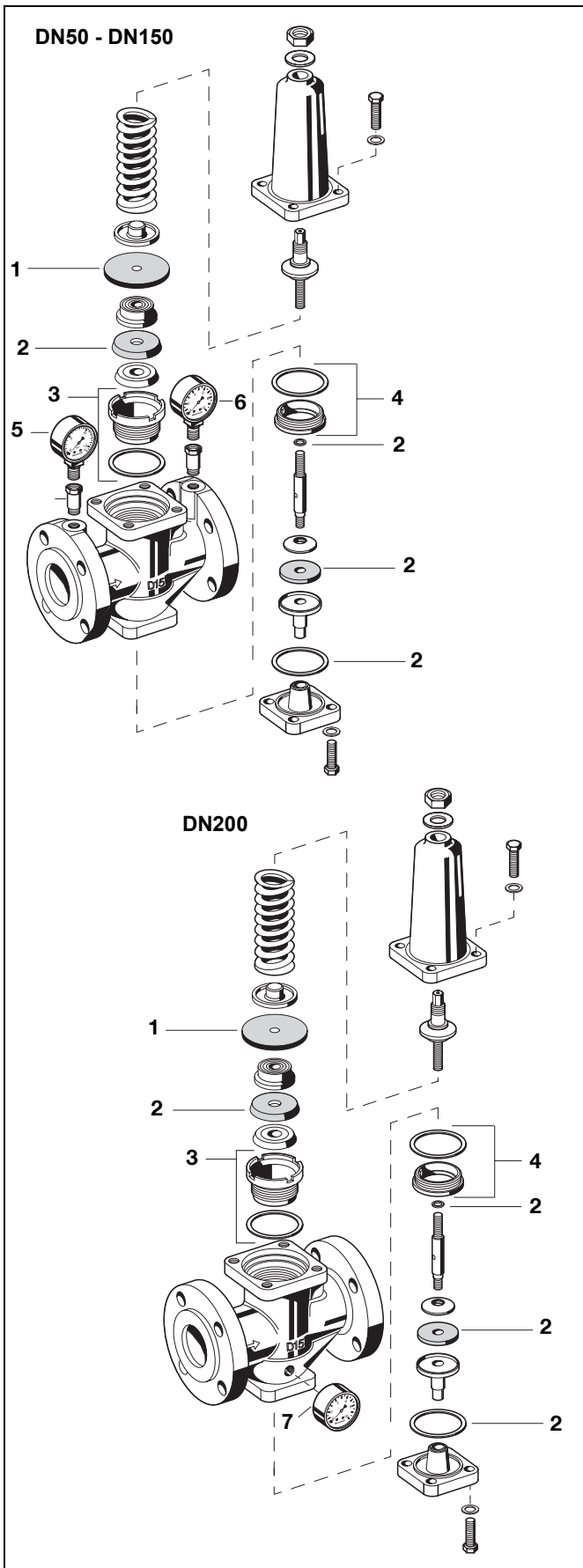

**Spare Parts**

**Pressure Reducing Valve D15P, from 2003 onwards**

No.	Description	Dimension	Part No.
1	Diaphragm for D15P and D17P	DN 50	5707300
		DN 65	5707400
		DN 80	5707500
		DN 100	5707600
		DN 125	5707700
		DN 150	5707800
		DN 200	5707900
		2	Set of seals
DN 65	0901354		
DN 80	0901355		
DN 100	0901356		
DN 125	0901357		
DN 150	0901358		
DN 200	0901359		
3	Guide bush with seal		
		DN 65	0900256
		DN 80	0900257
		DN 100	0900258
		DN 125	0900259
		DN 150	0900260
		DN 200	0900261
		4	Seat bush with seal
DN 65	0900248		
DN 80	0900249		
DN 100	0900250		
DN 125	0900251		
DN 150	0900252		
DN 200	0900253		
5	Pressure gauge		
	Ranges 0 - 16 bar		
6	Pressure gauge		M39M-A10
	Ranges 0 - 10 bar		
7	Pressure gauge		M07M-A10
		Ranges 0 - 10 bar (only for nominal size DN200)	

**Automation and Control Solutions**

Honeywell GmbH  
 Hardhofweg  
 D-74821 Mosbach  
 Phone: (49) 6261 810  
 Fax: (49) 6261 81309  
<http://europe.hbc.honeywell.com>  
[www.honeywell.com](http://www.honeywell.com)

Manufactured for and on behalf of the  
 Environment and Combustion Controls Division of  
 Honeywell Technologies Sàrl, Ecublens, Route du  
 Bois 37, Switzerland by its Authorised  
 Representative Honeywell GmbH  
 EN0H-1007GE25 R0307  
 Subject to change  
 © 2007 Honeywell GmbH

**Honeywell**