

FINE CONTROLS (UK) LTD



Fine Controls have been supplying process controls & instrumentation equipment since 1994, & now serves an ever expanding customer base, both in the UK & globally.

We offer a full range of valve & instrumentation products & services, with our product range representing leading technologies & brands:

Flow: Flow Meters & Transmitters, Flow Switches, Flow Control Valves & Batch Control Systems

Temperature: Temperature Probes & Thermowells, Temperature transmitters, Temperature Regulators & Temperature Displays

Level: Level Transmitters & Switches

Pressure: Pressure Gauges & Transmitters, Precision & High Pressure Regulators & I-P Converters, Volume boosters.

Precision Pneumatics: Pressure Regulators, I-P Converters, Volume Boosters, Vacuum Regulators

Valves: Solenoid & Pneumatic Valves, Control Valves & Positioners, Actuated Ball, Globe or Diaphragm Valves & Isolation Valves

Services: Repair, Calibration, Panel Build, System Design & Commissioning

A rotork® Brand
FAIRCHILD



bürkert



SIEMENS



alcon
SOLENOID VALVES

A rotork® Brand



MIDLAND-ACS
A rotork® Brand



Honeywell



Bourdon
Baumer Group



SOLDO
CONTROLS

A rotork® Brand



Fine Controls (UK) LTD, Bassendale Road, Croft Business Park,
Bromborough, Wirral, CH62 3QL UK
Tel: 0151 343 9966
Email: sales@finecontrols.com

D15NP

Pressure reducing valve with balanced seat Low pressure pattern

Product specification sheet

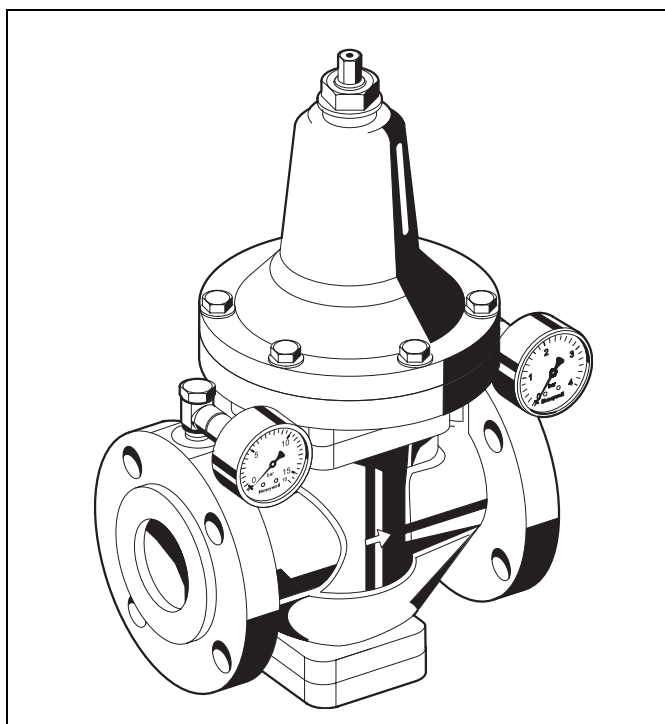

Construction

The pressure reducing valve comprises:

- Housing with PN16 flanges per ISO7005-2, EN1092-2
- Spring bonnet with adjustment screw
- Adjustment spring
- Valve system complete with diaphragm
- Pressure gauge

Materials

- Grey cast iron housing
- Cast iron spring bonnet
- Bronze valve seat
- Bronze piston guide
- Cone up to DN150: brass, DN200: steel
- Spring steel adjustment spring
- EPDM diaphragm
- NBR seal collar
- NBR seals
- Stainless steel screws and nuts

Application

Pressure reducing valves of this type protect installations against excessive pressure from the supply. They can be used for industrial or commercial applications within the range of their specification.

By installing a pressure reducing valve, pressurisation damage is avoided and water consumption is reduced.

The set pressure is also maintained constant, even when there is wide inlet pressure fluctuation.

Reduction of the operating pressure and maintaining it at a constant level minimizes flow noise in the installation.

Special Features

- Non-rising stem for setting outlet pressure and position indicator on spring bonnet (except for DN200)
- The adjustment spring is not in contact with the potable water
- With inlet and outlet pressure gauge (DN80-DN150) or with outlet pressure gauge (DN50, DN65, DN200)
- Inlet pressure balancing - fluctuating inlet pressure does not influence outlet pressure
- Powder coated inside and outside - Powder used is physiologically and toxicologically safe

Range of Application

Medium	Water, compressed air* and nitrogen* in consideration of valid standards (e.g. DIN EN 12502)
Inlet pressure	max. 16 bar
Outlet pressure	0.2 - 2 bar

Technical Data

Operating temperature	max. 70°C
Nominal pressure	PN16
Minimum pressure drop	0.5 bar
Diaphragm pressure loading	max. 3.0 bar
Nominal size	DN50 - DN200

* As part of an installation being approved according to PED requirements, this product must also be certified.

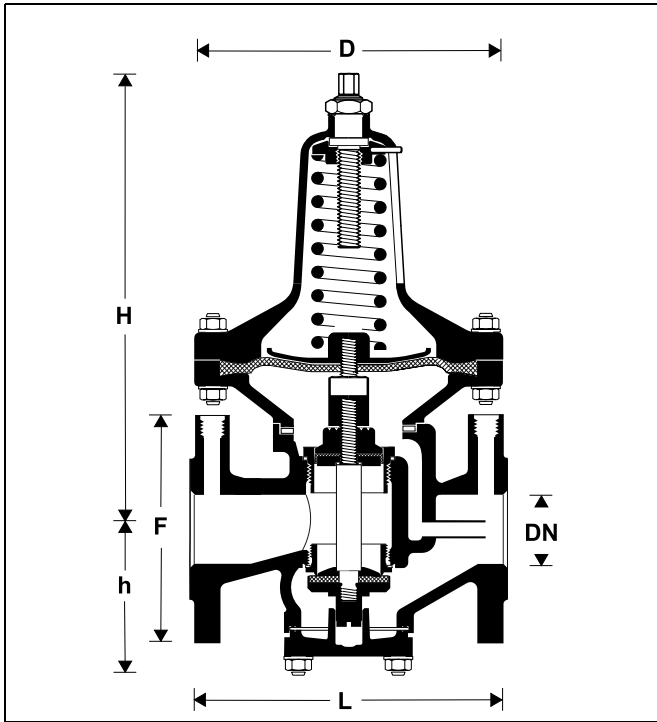

Method of Operation

Spring loaded pressure reducing valves operate by means of a force equalising system. The force of a diaphragm operates against the force of an adjustment spring. If the outlet pressure and therefore diaphragm force fall because water is drawn, the then greater force of the spring causes the valve to open. The outlet pressure then increases until the forces between the diaphragm and the spring are equal again.

The inlet pressure has no influence in either opening or closing of the valve. Because of this, inlet pressure fluctuation does not influence the outlet pressure, thus providing inlet pressure balancing.

Options

D15NP-... A = With PN 16 flanged connections to DIN 2533 and BS 4504, cast iron housing

Special Versions available on request
 Connection size

Connection size	DN	50	65	80	100	125	150	200
Weight	kg	21	37	54	87.5	135	196	580
Dimensions	mm							
	L	230	290	310	350	400	480	600
	approx. H	300	370	415	515	575	670	1430
	h	106	126	154	183	210	248	305
	D	192	260	295	410	440	510	780
F	165	185	200	220	250	285	340	
k _{vs} -value	m ³ /h	28	47	70	110	180	250	380

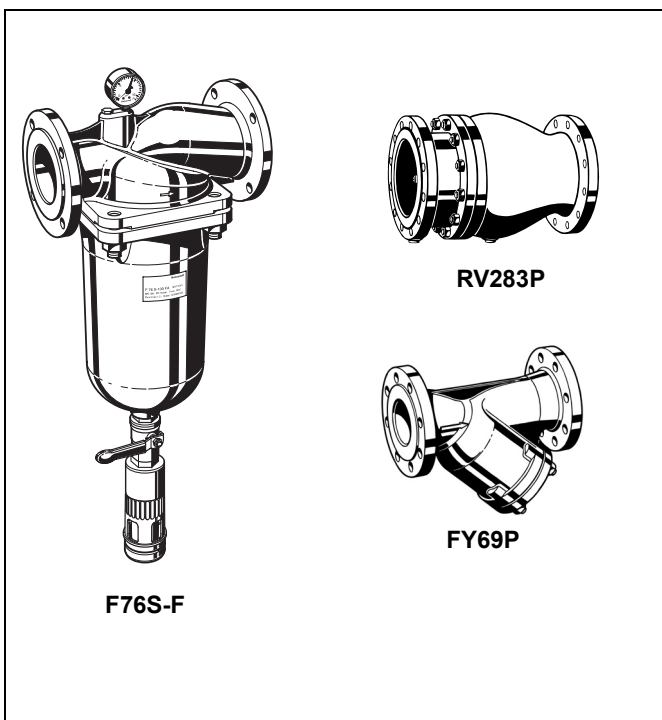

Accessories

RV283P Check valve

Grey cast iron housing, powder coated inside and outside. DIN/DVGW tested in compulsory test sizes DN 65, DN 80 and DN 100

FY69P Strainer

With double mesh, grey cast iron housing, powder coated inside and outside.

A = Mesh size approximately 0.5 mm

F76S-F Reverse-rinsing filter

Red bronze housing and filter bowl. Available in sizes DN 65 to DN 100, with filter mesh sizes 100 µm or 200 µm

Installation Example

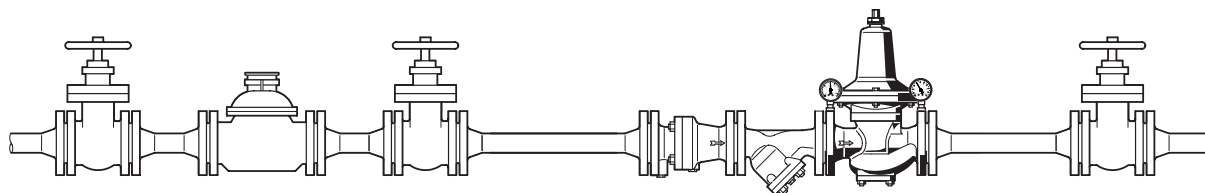

Connection size	DN	50	65	80	100	125	150	200
W*	mm	115	150	170	225	240	275	410

* Minimum distance from wall to centre line of pipework

Installation Guidelines

- Install in horizontal pipework with spring bonnet directed upwards
- Install shutoff valves
- The installation location should be protected against frost and be easily accessible
 - o Pressure gauge can be read off easily
 - o Simplified maintenance and cleaning
- Install downstream of the filter or strainer
 - o This position ensures optimum protection for the pressure reducing valve against dirt
- Provide a straight section of pipework of at least five times the nominal valve size after the pressure reducing valve (in accordance with DIN 1988, Part 5)

Typical Applications

Pressure reducing valves of this type are suitable for multi dwelling buildings, industrial and commercial applications within the range of their specifications.

Pressure reducing valves should be installed:

- If the static pressure exceeds the maximum permissible value for the system
- If several pressure zones are required when a pressurisation system is used (pressure reducers on each storey of a building)
- If pressure fluctuations in the downstream system must be avoided
- To achieve constant inlet and outlet pressures on pumped pressure boosting systems
- To reduce the water consumption

Flow Diagram

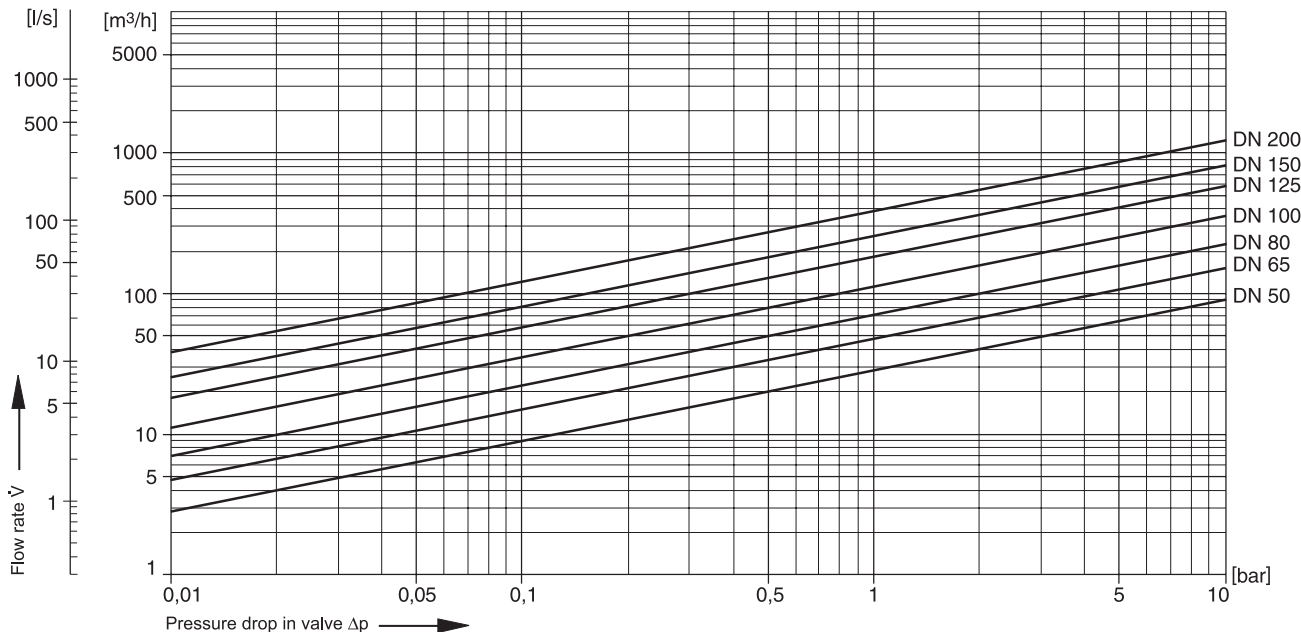

EN0H-1008GE23 R0307 • Subject to change without notice

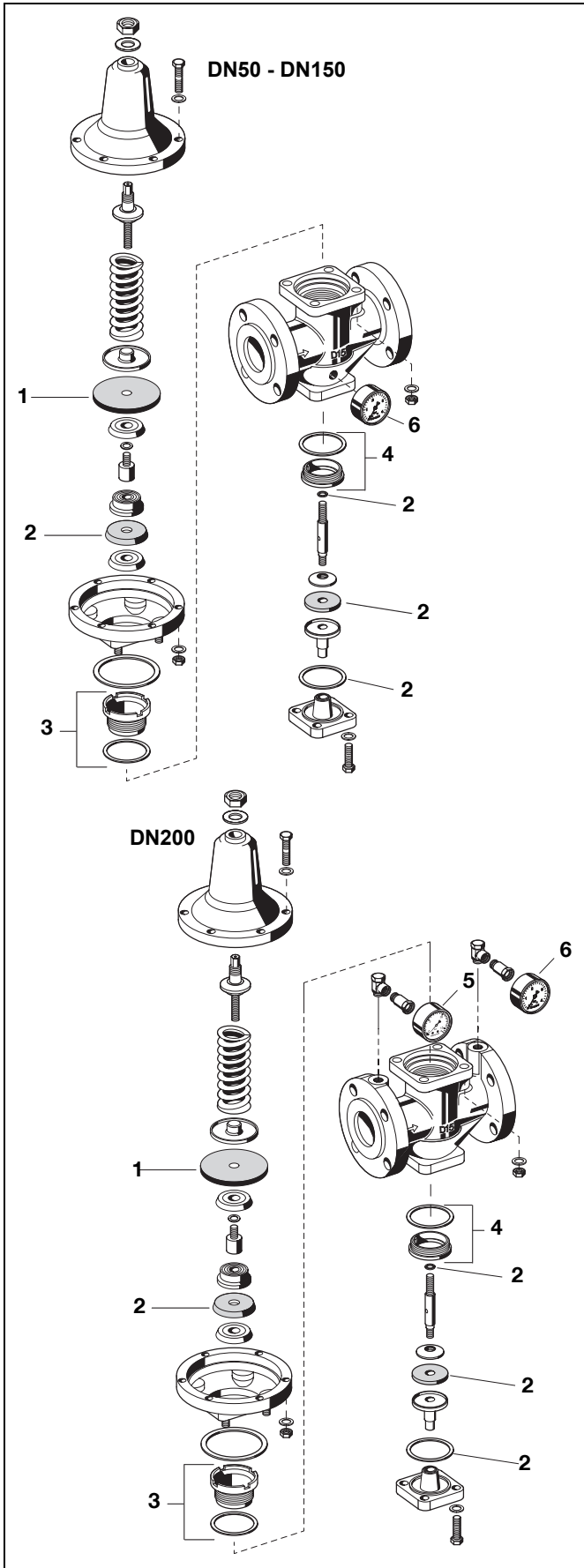

Spare Parts

Pressure Reducing Valve D15NP, from 2003 onwards

No.	Description	Dimension	Part No.
1	Diaphragm for D15NP	DN 50	5708000
		DN 65	5708100
		DN 80	5708200
		DN 100	5708300
		DN 125	5708400
		DN 150	5708500
		DN 200	5708600
2	Set of seals	DN 50	0901353
		DN 65	0901354
		DN 80	0901355
		DN 100	0901356
		DN 125	0901357
		DN 150	0901358
		DN 200	0901359
3	Guide bush with seal	DN 50	0900255
		DN 65	0900256
		DN 80	0900257
		DN 100	0900258
		DN 125	0900259
		DN 150	0900260
		DN 200	0900261
4	Seat bush with seal	DN 50	0900247
		DN 65	0900248
		DN 80	0900249
		DN 100	0900250
		DN 125	0900251
		DN 150	0900252
		DN 200	0900253
5	Pressure gauge Ranges 0 - 16 bar		M07M-A16
6	Pressure gauge Ranges 0 - 4 bar		M07M-A4

Automation and Control Solutions

Honeywell GmbH
 Hardhofweg
 D-74821 Mosbach
 Phone: (49) 6261 810
 Fax: (49) 6261 81309
<http://europe.hbc.honeywell.com>
www.honeywell.com

Manufactured for and on behalf of the
 Environment and Combustion Controls Division of
 Honeywell Technologies Sàrl, Ecublens, Route du
 Bois 37, Switzerland by its Authorised
 Representative Honeywell GmbH
 EN0H-1008GE25 R0307
 Subject to change
 © 2007 Honeywell GmbH

Honeywell