

# FINE CONTROLS (UK) LTD



Fine Controls have been supplying process controls & instrumentation equipment since 1994, & now serves an ever expanding customer base, both in the UK & globally.

We offer a full range of valve & instrumentation products & services, with our product range representing leading technologies & brands:

**Flow:** Flow Meters & Transmitters, Flow Switches, Flow Control Valves & Batch Control Systems

**Temperature:** Temperature Probes & Thermowells, Temperature transmitters, Temperature Regulators & Temperature Displays

**Level:** Level Transmitters & Switches

**Pressure:** Pressure Gauges & Transmitters, Precision & High Pressure Regulators & I-P Converters, Volume boosters.

**Precision Pneumatics:** Pressure Regulators, I-P Converters, Volume Boosters, Vacuum Regulators

**Valves:** Solenoid & Pneumatic Valves, Control Valves & Positioners, Actuated Ball, Globe or Diaphragm Valves & Isolation Valves

**Services:** Repair, Calibration, Panel Build, System Design & Commissioning

A rotork® Brand  
**FAIRCHILD**



**bürkert**



**SIEMENS**



**alcon**  
SOLENOID VALVES

A rotork® Brand



**MIDLAND-ACS**  
A rotork® Brand



**Honeywell**



**Bourdon**  
Baumer Group



**SOLDO**  
CONTROLS

A rotork® Brand



Fine Controls (UK) LTD, Bassendale Road, Croft Business Park,  
Bromborough, Wirral, CH62 3QL UK  
Tel: 0151 343 9966  
Email: sales@finecontrols.com

# ROTORK FAIRCHILD MODEL T7500 LOW PRESSURE TRANSDUCER

## Installation, Operation and Maintenance Instructions

### Introduction

The T7500 series low pressure transducer is a precision low pressure electro-pneumatic transducer designed to satisfy demanding electronic pressure control applications in ranges from 0-1 to 0-15 psig. The transducer's vibration resistant pilot stage employs piezo-ceramic actuator flapper nozzle technology to control the sensitive integral pneumatic volume booster. The volume booster's highly sensitive control diaphragm and main valve accurately control the flow of air to the downstream system in response to the pressure sensor provides unparalleled accuracy at very low pressures in response to the electronic control input signals. All this in a compact package size.

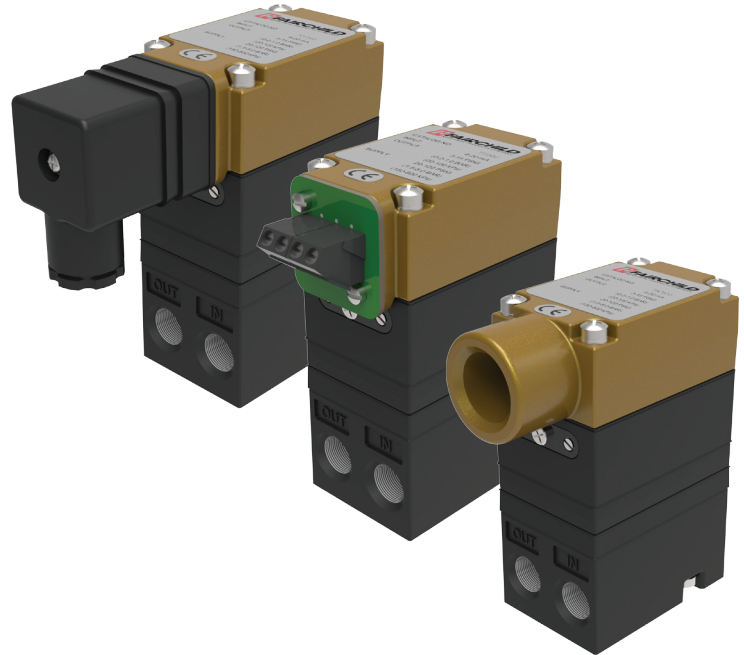

### Features

The T7500 Series Transducers provide maximum versatility for precision low pressure applications.

- Field Reversible Feature provides output that is inversely proportional to input signal.
- RFI/EMI Protection eliminates susceptibility to electromagnetic and radio interference.
- Internal Electronic Feedback and solid state controlled Piezoelectric Actuator provide precise control of output pressure regardless of vibration or position.
- Damping Adjustment for optimum tuning response.
- Unaffected by vibration or mounting orientation.
- Compact size for use in restricted spaces.
- Various mounting configurations allow installation flexibility for most applications.
- NEMA 4X, Type 4 Enclosure and IP65 rated for indoor and outdoor installations.
- All T7500 products are ROHS compliant.

### Ordering Information

<b>Catalog Number</b>	T	<input type="checkbox"/>	75	<input type="checkbox"/>	<input type="checkbox"/>	<input type="checkbox"/>	<input type="checkbox"/>	<input type="checkbox"/>
<b>Electrical Connection:</b>								
1/2" NPT Conduit w/pigtail .....	A							
EN 175301-803.....	D							
Terminal Block .....	T							
<b>Main Valve:</b>								
3 scfm valve.....			01					
7 scfm valve.....			02					
<b>Input:</b>								
0-10 VDC .....				0				
4-20 mA .....				4				
0-5 VDC.....					7			
<b>Output:</b>								
0-2.5 PSIG .....						01		
0-5 PSIG .....						02		
0-7.5 PSIG .....						03		
0-15 PSIG .....						04		
0-0.17 Bar.....						11		
0-0.35 Bar .....						12		
0-0.5 Bar .....						13		
0-1 Bar.....						14		
0-17 kPa .....						21		
0-35 kPa .....						22		
0-50 kPa .....						23		
0-100 kPa.....						24		
<b>Port Thread:</b>								
NPTF .....								N
BSPT .....								U

# ROTORK FAIRCHILD MODEL T7500 LOW PRESSURE TRANSDUCER

## Installation, Operation and Maintenance Instructions

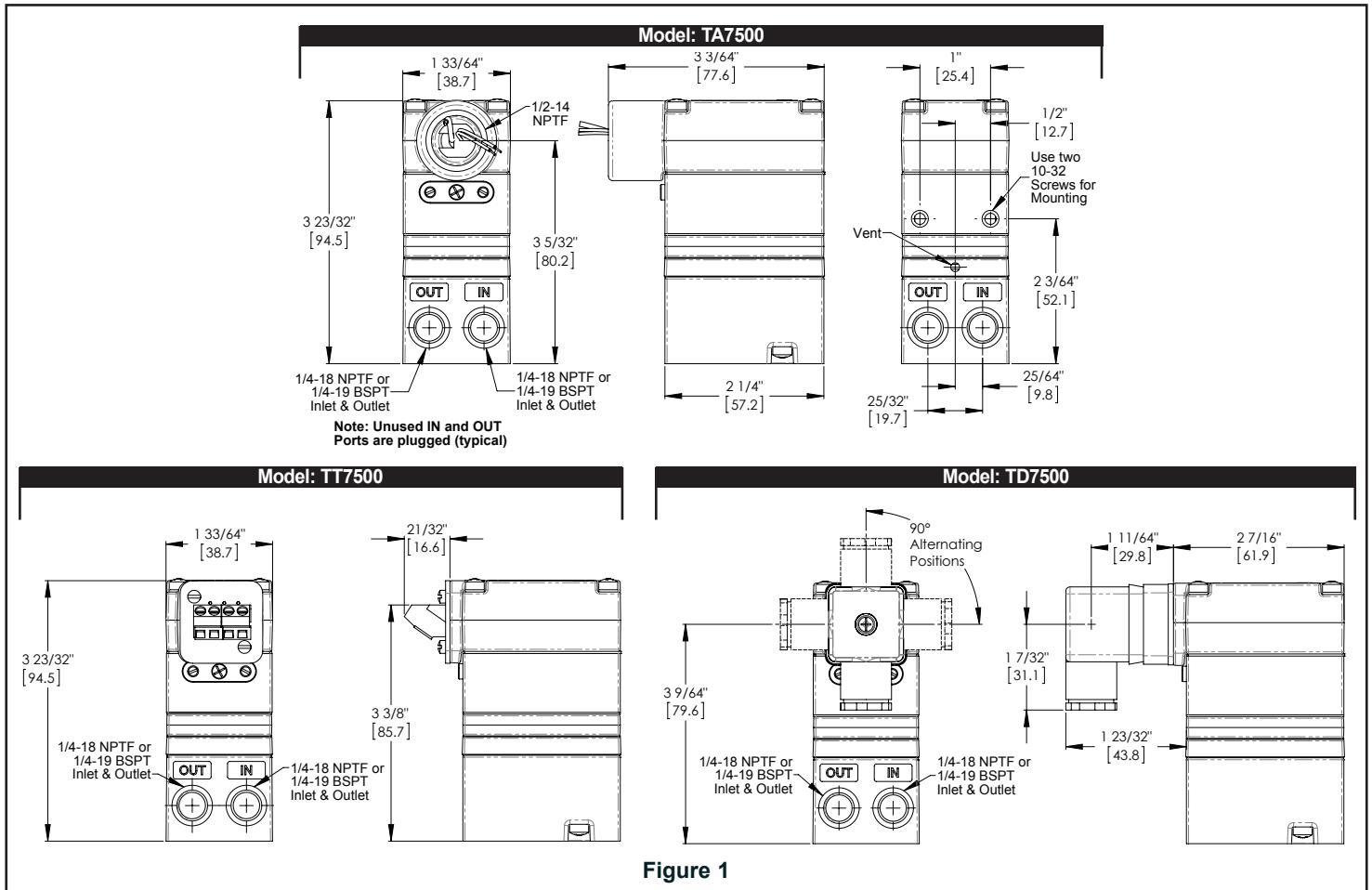
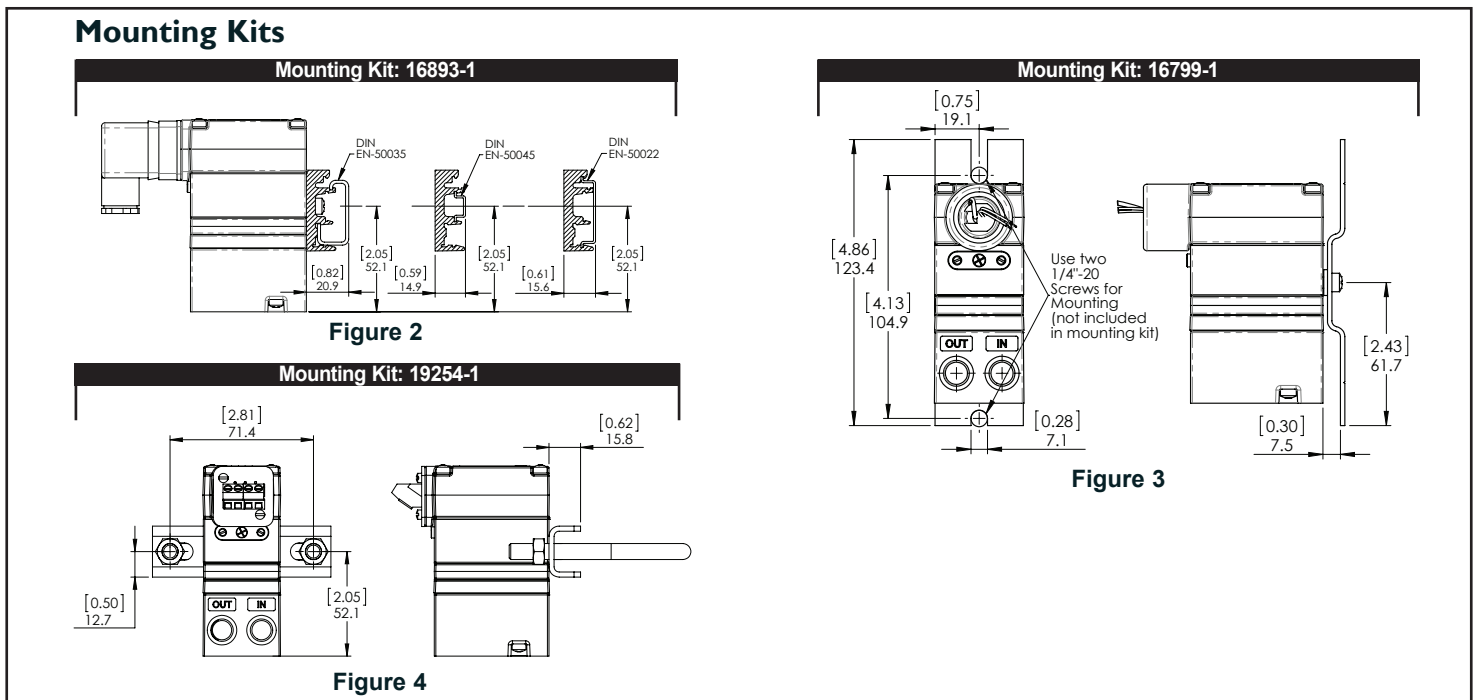

Figure 1



# ROTORK FAIRCHILD MODEL T7500 LOW PRESSURE TRANSDUCER

## Installation, Operation and Maintenance Instructions

### Specifications

**Supply Pressure**  
20-30 psig, [1.4-2.0 Bar]

Accuracy (ISA S51.1)  
0.25% Full Scale Guaranteed  
0.10% Full Scale Typical

#### Flow Rate (SCFM)

##### T7501

3 (5 m<sup>3</sup>/hr) @  
30 psig, [2 Bar] Supply  
5 psig, [350 mBar] Output

##### T7502

7 (11.7 m<sup>3</sup>/hr) @  
30 psig, [2 Bar] Supply  
15 psig, [1 Bar] Output

### Supply Voltages

**Three Wire Voltage Input** 7.2-30 VDC, less than 3 mA

### Materials of Construction

Body and Housing..... Chromate Treated Aluminum  
Orifice..... Nickel Plated Brass & Sapphire  
Trim..... Stainless Steel, Brass & Zinc Plated Steel  
Elastomers..... Nitrile  
Finish..... Epoxy Powder Coating

### Electrical Connections

Make connections to the Terminal Block, Conduit Connector or the DIN Connector as shown below.

DIN Connector  
(Current Unit)

TERMINAL	CONNECTION
1	Positive (+)
2	Negative (-)
3	Not Used
4	Ground (≡)

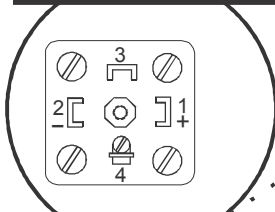

TERMINAL	CONNECTION
1	(+) Signal
2	(-) Supply/Signal
3	(+) Supply
4	(≡) Ground

DIN Connector  
(Voltage Unit)

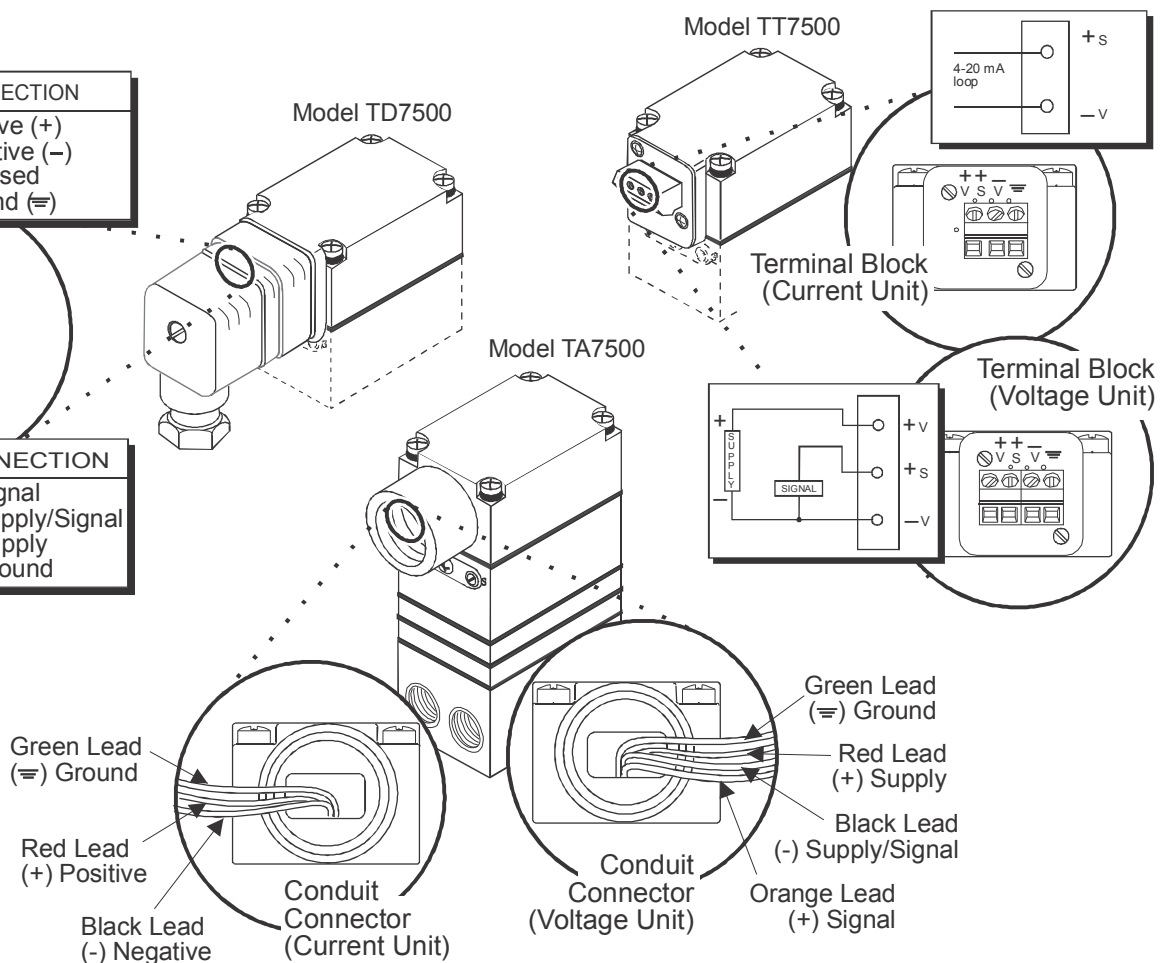

Figure 5

## INSTALLATION

You can mount the Model T7500 on a flat surface using two 10-32 Screws. For more information, see Figure 1.

The Model T7500 ships from the factory with Mounting Kit 16799-1 for Panel or Wall Mounting and Mounting Bracket Kit 16893-1 for Din Rail Mounting. For more information, see Figure 2 and Figure 3.

An optional mounting kit, 19254-1, is available to install the unit on a 2" pipe. For more information, see Figure 4.

### NOTE:

**Part of the TD7500 enclosure is constructed of Non-Metallic material. To prevent the risk of electrostatic sparking, the enclosure shall only be cleaned with a damp cloth. For more information, see Figure 6.**

## PNEUMATIC CONNECTIONS

Clean all pipelines to remove dirt and scale before installation.

Apply a minimum amount of pipe compound to the male threads of the air line only. **Do not use Teflon tape as a sealant.** Start with the third thread back and work away from the end of the fitting to avoid contaminating the transducer.

The inlet and outlet ports are labeled on the ends of the transducer. Tighten all connections securely. Avoid undersized fittings that will limit the flow through the transducer. For more information, see Figure 1.

### NOTE:

**Instrument quality air, per ISA Standards S7.3-1981, is required. Use a filter to remove dirt and liquid in the air line ahead of the transducer. If an air line lubricator is used, it MUST be located downstream to avoid interference with transducer performance.**

**The user is responsible for ensuring that the environment in which the unit is installed and the operating gas are compatible with the materials in the transducer.**

## CALIBRATIONS / ADJUSTMENTS

The following adjustments are provided:

- Full Range Operation
- Lo/Hi Span
- Forward /Reverse Mode
- Calibration - Zero and Span
- Damping Adjustments

## FULL-RANGE OPERATION

### Lo/Hi Span Adjustment

The T7500 transducers feature a Hi and Lo Span jumper to configure the span range of the unit. There are basically two pressure ranges for the T7500; 0-5 psig and 0-15 psig. The 0-2.5 psig and 0-7.5 psig range units are 0-5 psig and 0-15 psig range units with the span jumper in the *Lo Span* position. Table 1 below shows the relationship between the T7500 pressure range and span jumper position.

Model Pressure Range	Basic Pressure Range	Span Jumper Position
0-2.5 PSIG	0-5 PSIG	Lo
0-5 PSIG	0-5 PSIG	Hi
0-7.5 PSIG	0-15 PSIG	Lo
0-15 PSIG	0-15 PSIG	Hi

### Zero & Span Adjustment

#### Forward Acting Mode

1. Set Fwd/Rev Mode jumpers to the Forward position (Factory default)
2. Apply the minimum input signal and adjust the ZERO Adjustment for the desired minimum output pressure.
3. Apply the maximum input signal and adjust the Span Adjustment for the desired maximum output pressure.
4. Repeat steps 3 and 4 until the desired output range is obtained.

#### Reverse Acting Mode

**NOTE: Do NOT reverse the input leads.**

5. Set FWD/REV Mode jumpers to the Reverse position (see Figure 7).
6. Apply the maximum input signal and adjust the ZERO Adjustment for the desired minimum output pressure.
7. Apply the minimum input signal and adjust the SPAN Adjustment for the desired maximum output pressure.
8. Repeat steps 6 and 7 until the desired output range is obtained.

### Damping Adjustment

(See Figure 7)

- The damping adjustment lets you tune the transducer for optimum response and stability in a particular application.
- For best performance, start with the Damping Adjustment at maximum adjustment, fully clockwise. Gradually turn counterclockwise until output pressure begins oscillation. Turn clockwise until oscillation is minimized.

# Calibrations / Adjustments (continued)

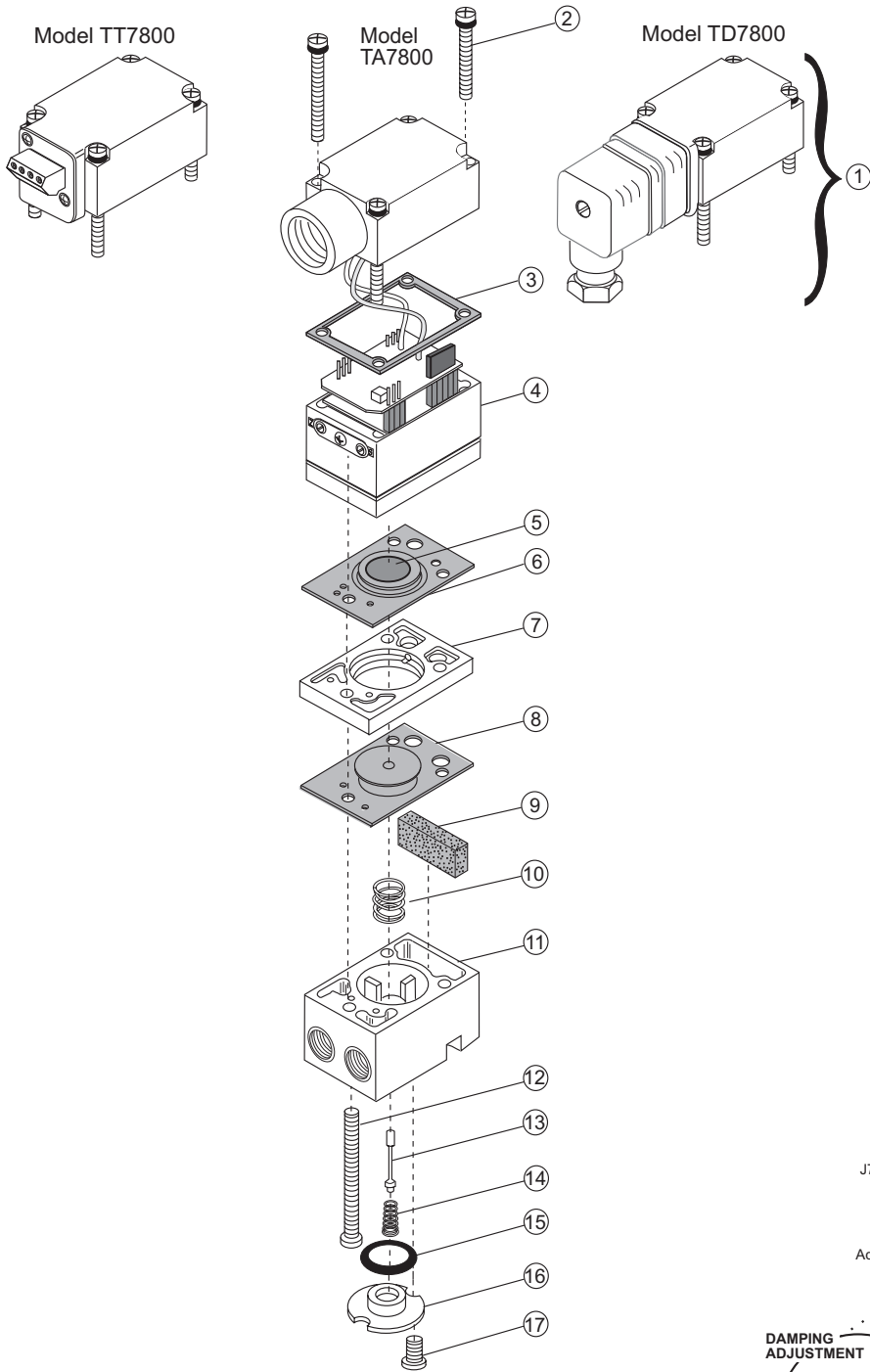

Figure 6

Table 2 - T7500 Transducer Components		
Item	Qty.	Description
1	1	Cover Machining
2	4	Screw
3	2	Gasket
4 <sup>1</sup>	1	Nozzle Body Assembly
5	1	Disk
6 <sup>1</sup>	1	Diaphragm
7	1	Spacer Ring
8 <sup>1</sup>	1	Diaphragm Assembly
9 <sup>1</sup>	1	Spring
10	1	Valve Body Assembly
11 <sup>1</sup>	1	Foam Block
12 <sup>1</sup>	1	Screw
13	1	Pintle
14	3	Spring, Pintle
15	1	O-Ring
16	1	Plug
17 <sup>1</sup>	1	Screw

<sup>1</sup> 22485-1 Service Kit Components.

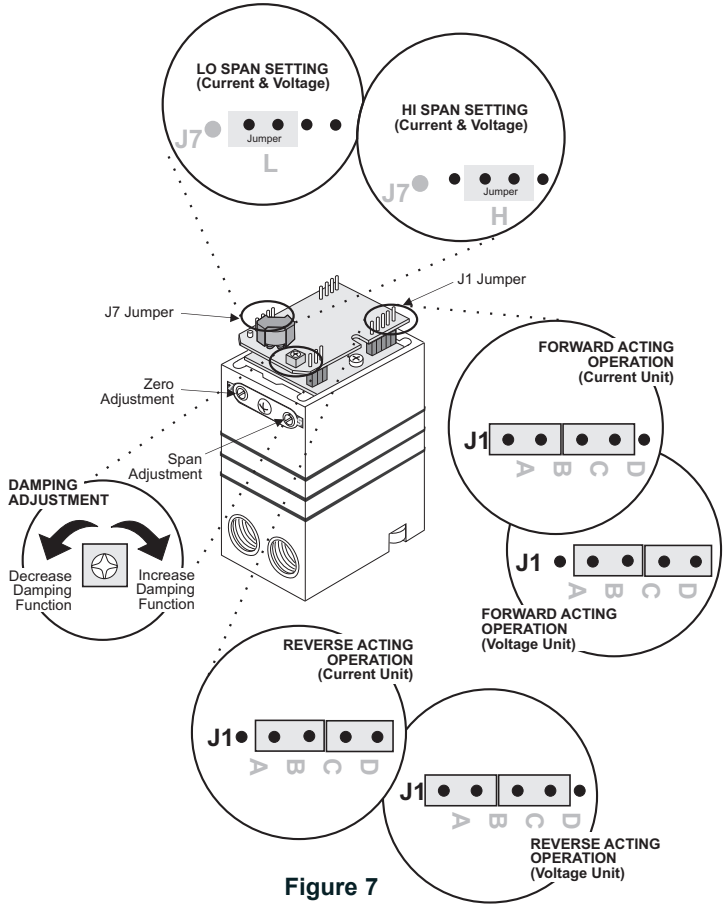

Figure 7

## MAINTENANCE

To clean the Orifice, use the following procedure:

1. Shut off the valve that supplies air to the Transducer.
2. Remove the Transducer from the air line.
3. Remove the 3 screws from the bottom of the Transducer.
4. Locate the Orifice in the Spacer Ring.
5. Clean with alcohol and compressed air.
6. Reassemble the unit.

NOTE: Parts must be completely dry before reassembling.

**NOTE: If troubleshooting solution and maintenance procedure does not correct the problem, install the Service Kit.**

### 22485-1 Service Kit, T7500 Transducer

Table 3 - Troubleshooting	
Problem	Solution (check)
No Output	<ul style="list-style-type: none"><li>• Supply pressure</li><li>• Clogged orifice</li></ul>
Leakage	<ul style="list-style-type: none"><li>• Connections</li></ul>
Low or improper Span adjust	<ul style="list-style-type: none"><li>• Zero and Span adjust</li><li>• Low supply pressure</li><li>• Output leakage</li></ul>
Erratic operation	<ul style="list-style-type: none"><li>• DC signal</li><li>• Loose wires or connections</li><li>• Liquid in air supply</li></ul>

### LEGAL NOTICE:

The information set forth in the foregoing Installation, Operation and Maintenance Instructions shall not be modified or amended in any respect without prior written consent of Fairchild Industrial Products Company. In addition, the information set forth herein shall be furnished with each product sold incorporating Fairchild's unit as a component thereof.



FAIRCHILD INDUSTRIAL PRODUCTS COMPANY  
REGISTERED TO ISO 9001:2008  
10002346 QM08

