

# FINE CONTROLS (UK) LTD



Fine Controls have been supplying process controls & instrumentation equipment since 1994, & now serves an ever expanding customer base, both in the UK & globally.

We offer a full range of valve & instrumentation products & services, with our product range representing leading technologies & brands:

**Flow:** Flow Meters & Transmitters, Flow Switches, Flow Control Valves & Batch Control Systems

**Temperature:** Temperature Probes & Thermowells, Temperature transmitters, Temperature Regulators & Temperature Displays

**Level:** Level Transmitters & Switches

**Pressure:** Pressure Gauges & Transmitters, Precision & High Pressure Regulators & I-P Converters, Volume boosters.

**Precision Pneumatics:** Pressure Regulators, I-P Converters, Volume Boosters, Vacuum Regulators

**Valves:** Solenoid & Pneumatic Valves, Control Valves & Positioners, Actuated Ball, Globe or Diaphragm Valves & Isolation Valves

**Services:** Repair, Calibration, Panel Build, System Design & Commissioning

A rotork® Brand  
**FAIRCHILD**



**bürkert**



**SIEMENS**



**alcon**  
SOLENOID VALVES

A rotork® Brand



**MIDLAND-ACS**  
A rotork® Brand



**Honeywell**



**Bourdon**  
Baumer Group



**SOLDO**  
CONTROLS

A rotork® Brand



Fine Controls (UK) LTD, Bassendale Road, Croft Business Park,  
Bromborough, Wirral, CH62 3QL UK  
Tel: 0151 343 9966  
Email: sales@finecontrols.com

# FAIRCHILD T5220 SERIES ELECTRO-PNEUMATIC TRANSDUCER

## Installation, Operation and Maintenance Instructions

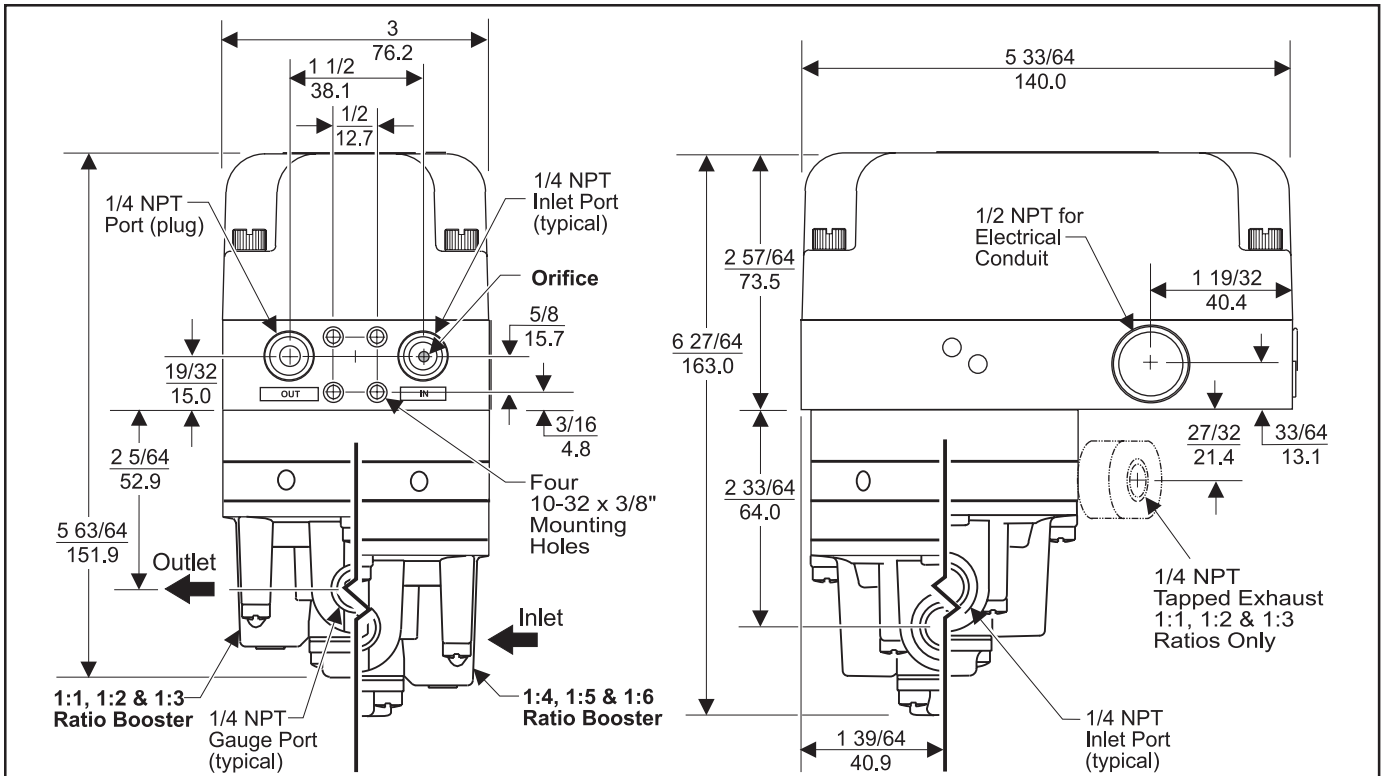

**Figure 1. Model T5220 Outline Dimensions**

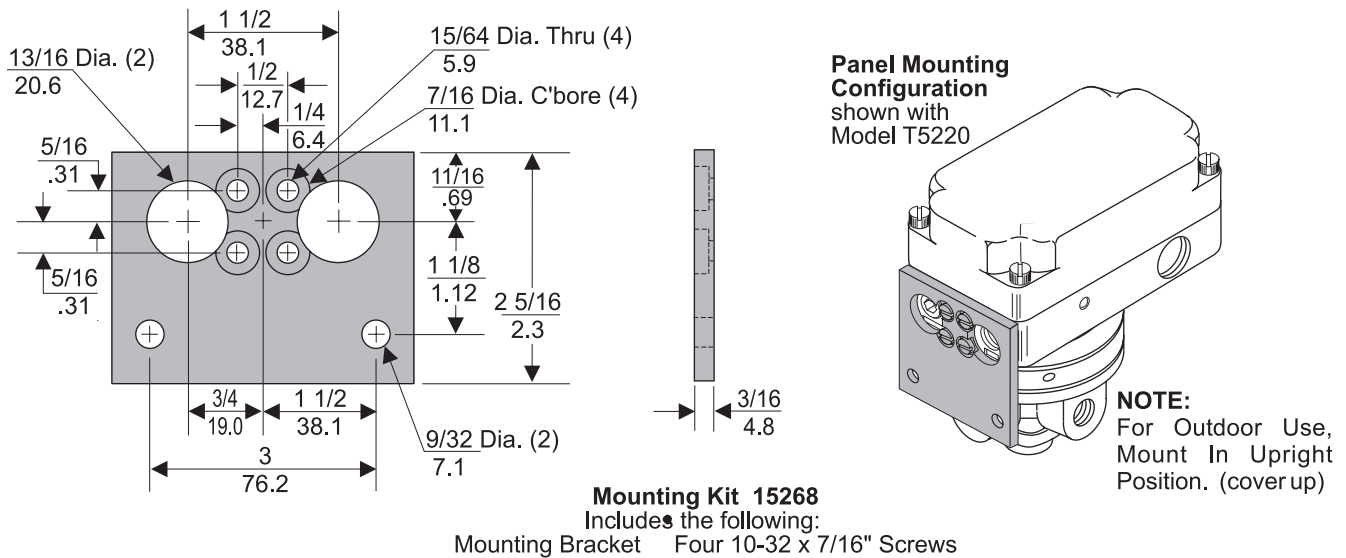

**Figure 2. Mounting Kit 15268. (Sold Separately)**

## INSTALLATION

The Model T5220 can be mounted directly onto a flat surface using the two 10-32 tapped mounting holes in the base of the housing. For more information, see Figure 1. "T5220 Outline Dimensions" above.

The Model T5220 can be Panel Mounted using the mounting bracket supplied in Mounting Kit 15268. For more information, see Figure 2. above.

**Installation (Continued)**

The Model T5420 can be mounted on a 2" pipe using the Optional Mounting Kit 14596. For more information, see Figure 3. below.

**NOTE:**

For outdoor use, mount the T5220 in an upright position. This will help prevent rain water from entering into the unit. For more information, see Figure 3. "Mounting Kit 14596" below.

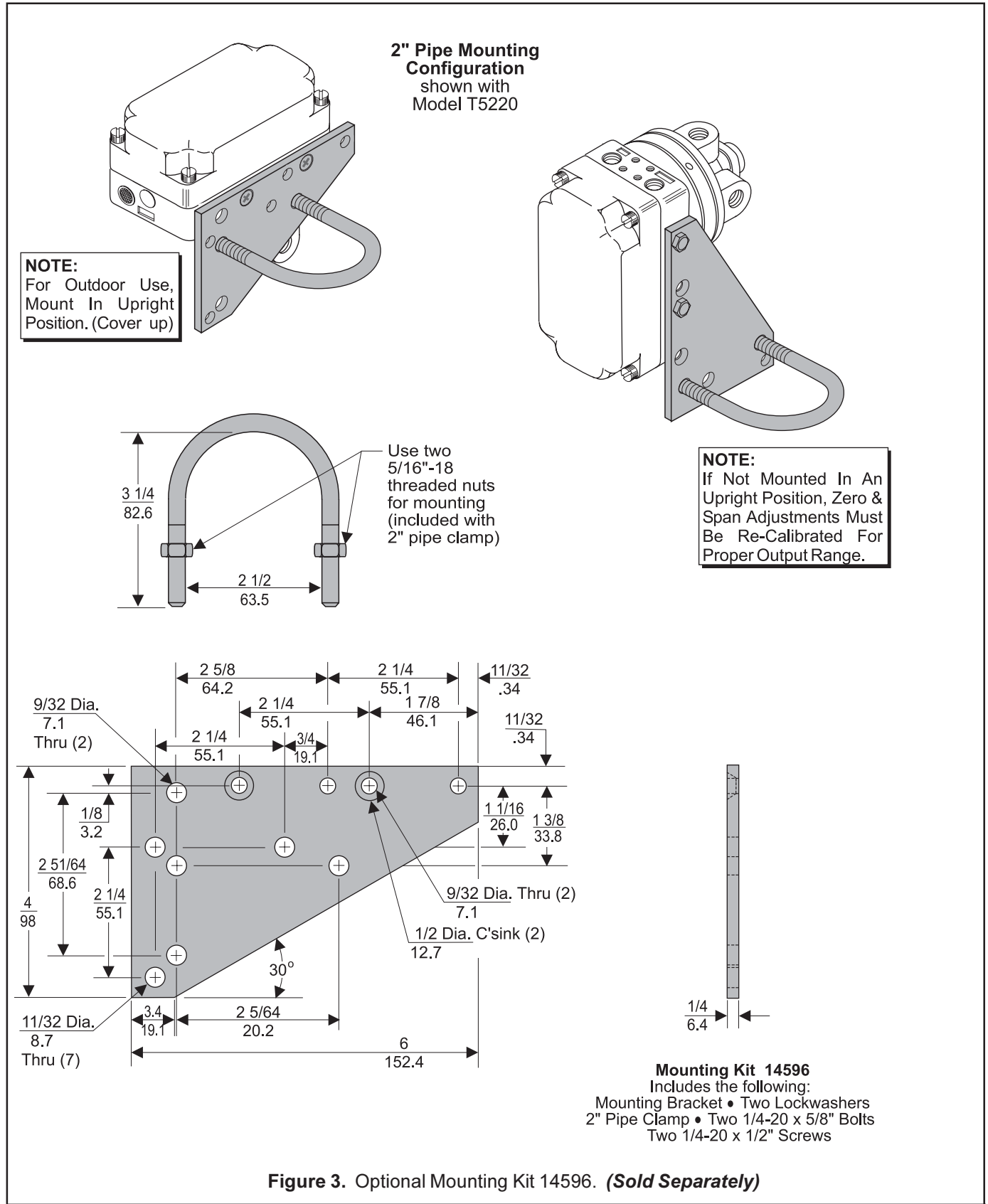

## INSTALLATION

The Model TXPD5220 can be mounted directly onto a flat surface using the four 1/4-20 x 7/16 tapped mounting holes in the base of the housing. For more information, see Figure

4. "TXPD5220 Outline Dimensions" below. Mounting Kit 14140 is available for Panel or 2" Pipe Mounting. For more information, see Figure 5 below.

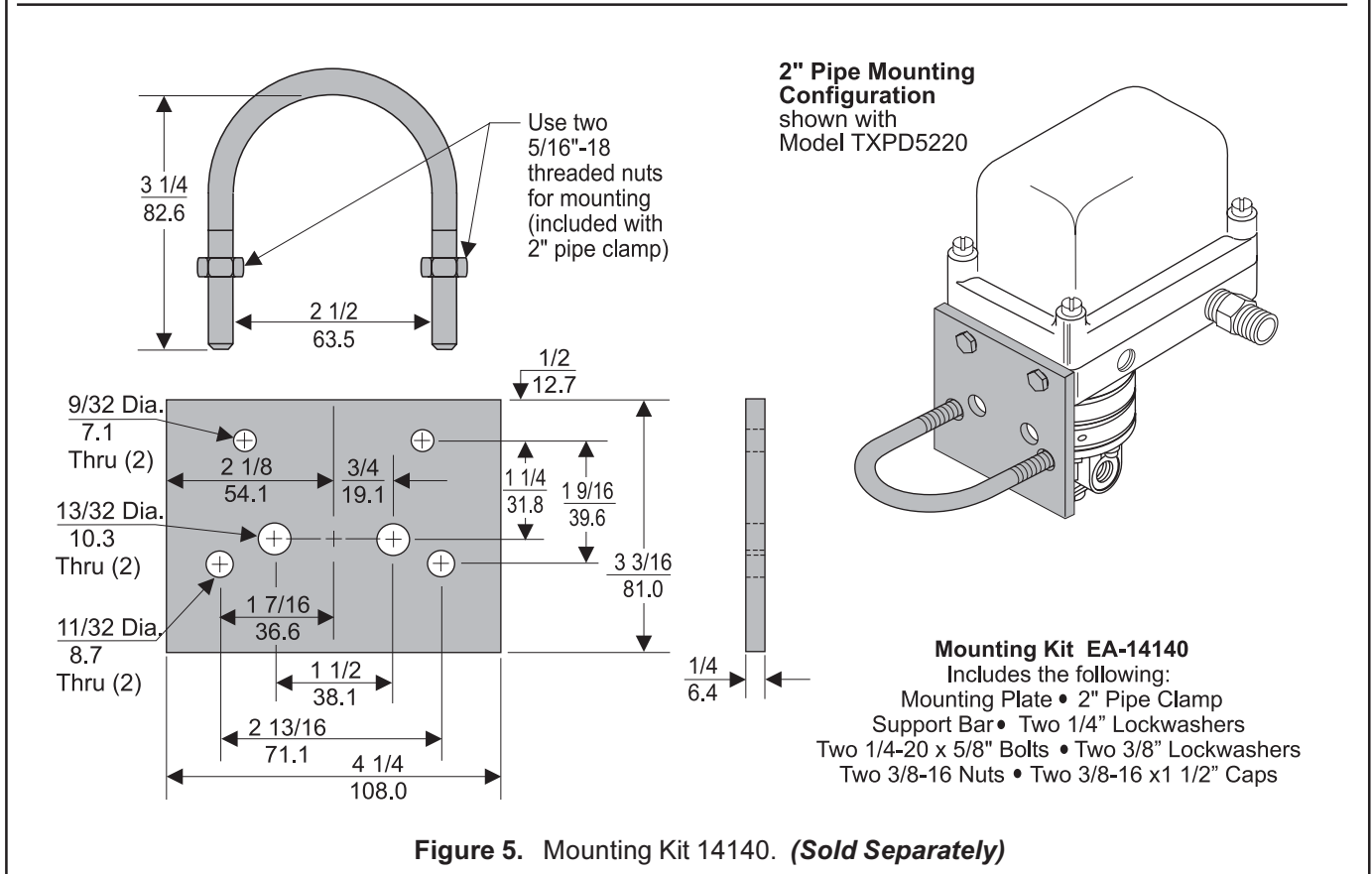
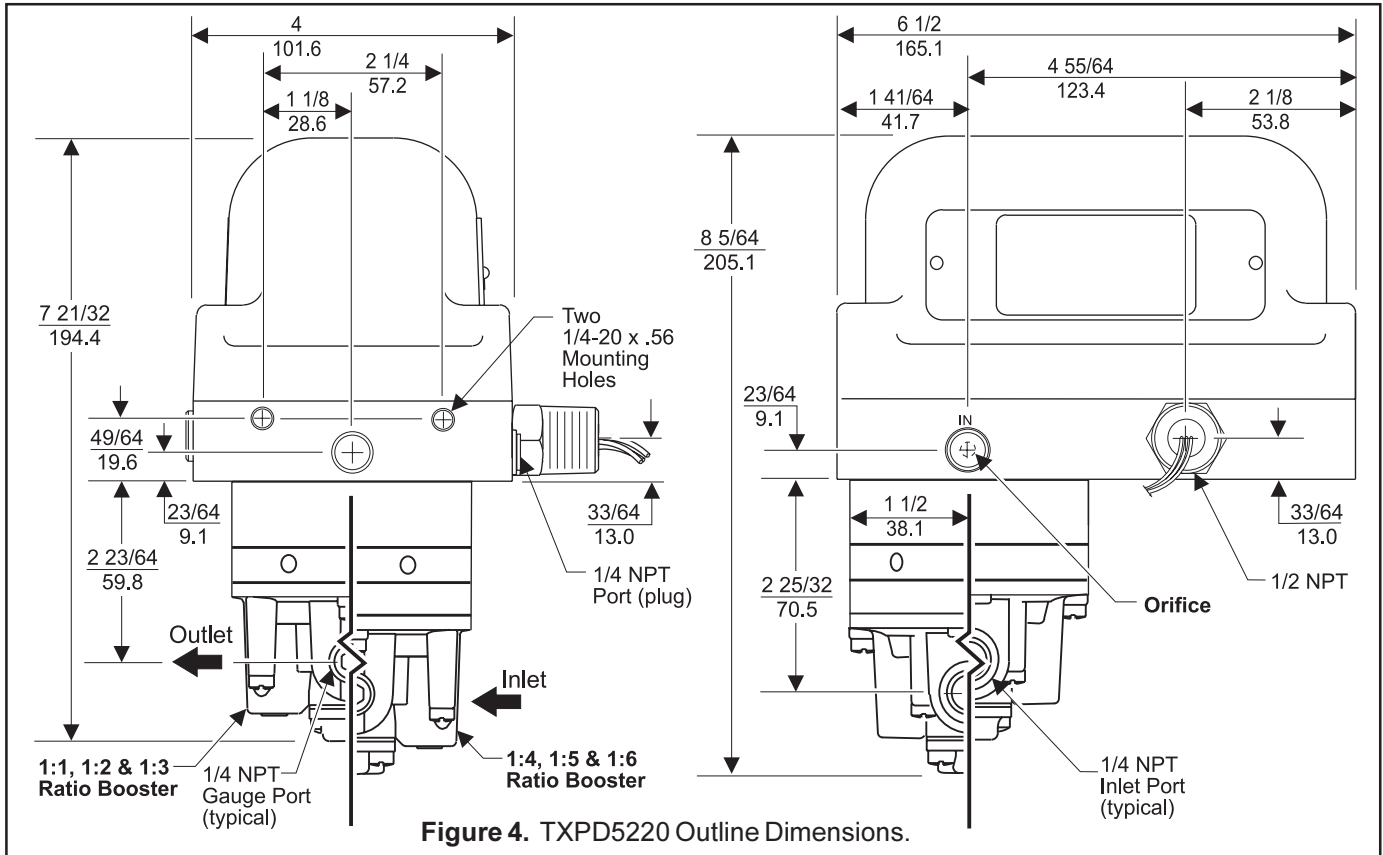

## Pneumatic Connections

Clean all pipelines to remove dirt and scale before installation.

Apply a minimum amount of pipe compound to the male threads of the fitting only. **Do Not use teflon tape as a sealant.** Start with the third thread back and work away from the end of the fitting to avoid the possibility of contaminating the transducer. Install the transducer in the air line.

**NOTES:** Instrument quality air, per ISA Standards D7.3-1981, is required. Use a filter to remove dirt and liquid in the air line ahead of the transducer for correct performance. If an air line lubricator is used, it **MUST** be located downstream, beyond the transducer.

The user is responsible for insuring that the environment in which the unit will be installed, and the operating gas, are compatible with the materials in the trans-

**WARNING:** To prevent possible ignition of hazardous atmosphere, **DO NOT REMOVE COVER** from the TXPD5220 Transducer while current is on.

To maintain Explosion-Proof capability, **DO NOT DAMAGE** mating surfaces between cover and base. **NEVER ADD GASKETS.**

## Electric Connection

For the T5220 Transducer, make connections to the Terminal Block through a 1/2 NPT Conduit Connector (not supplied) and a plastic sleeve as shown below in Figure 7. "Electrical Connections".

For the TXPD5220 Transducer, make connections from the Sealed Connector Wires to an external Terminal Block. The TXPD5220 Transducer has an additional ground wire that is used. For more information, see Figure 7. "Electrical Connections" below.

**NOTE:** The T5220 & TXPD5220 should be wired in accordance with the wiring diagram inside of cover.

## Wiring in Hazardous Areas

Wiring in hazardous areas should be performed in accordance with the Table 1. and any local codes that apply.

Country	Agency	Code
U.S. Canada	FM CSA	ANSI/ISARP 12.6 & ANSI/NFPA 70 CEC Part 1

## Intrinsically Safe Connections

Refer to the latest revision of the indicated drawing.

Underwriting Group	Drawing Number
FM (Factory Mutual) CSA (Canadian Standards)	EC-14007 EC-16097

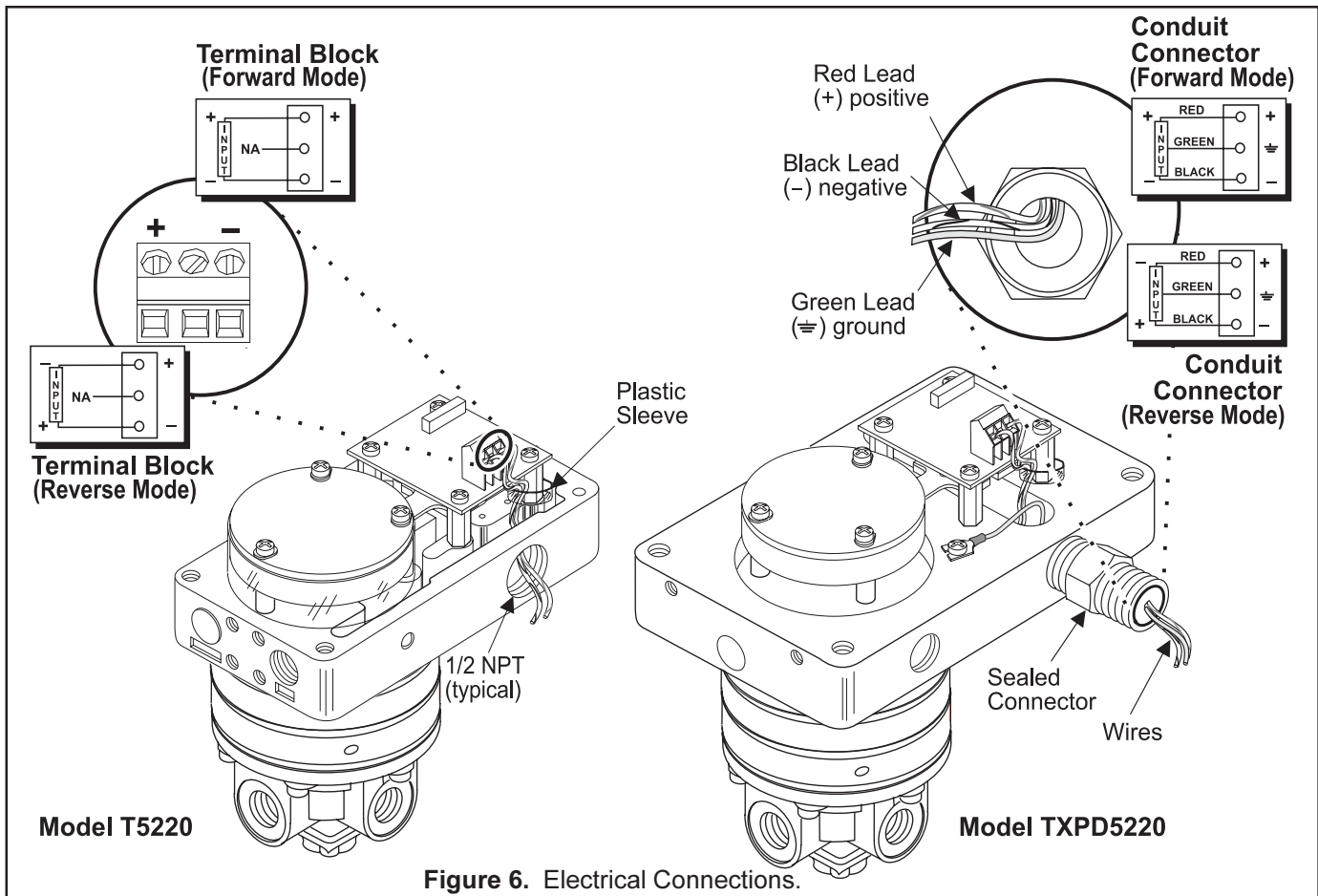

Figure 6. Electrical Connections.

## CALIBRATIONS / ADJUSTMENTS

### Equipment Required for Calibration:

- Pneumatic Supply capable of delivering up to 150 psig.
- Current Supply capable of delivering up to 50 mA.
- Voltage Supply capable of delivering up to 10 VDC.
- Pressure Gage capable of a digital readout up to 50 psig with an accuracy of .1%.
- Digital Volt Meter capable of a readout up to 30 mA or 10 VDC with an accuracy of .02%.

### The following adjustments are provided:

Full Range Operation  
Forward/Reverse Mode  
Calibration - Zero and Span

### FULL RANGE OPERATION

#### Forward Acting Mode Adjustment

**NOTE: Air Supply must be on before adjustments are made.**

1. Connect the input signal to the transducer as shown in Figure 6. "Electrical Connections."
- Forward Acting Calibration-Zero
  2. Apply the minimum input signal and adjust the Zero screw for minimum output pressure. Turn screw counterclockwise to increase pressure and clockwise to decrease pressure.

#### Forward Acting Calibration-Span

3. Apply the maximum input signal and adjust the Span screw on the potentiometer for maximum output pressure. Turn screw clockwise to increase pressure and counterclockwise to decrease pressure.
4. Repeat steps 2-3 until the desired output range is obtained. For more information, see Figure 7. "T5220/ TXPD5220 Calibration Configuration."

### Reverse Acting Mode Adjustment

**NOTE: Intrinsically safe units cannot be set for reverse acting mode in field.**

5. Connect the input signal to the transducer as shown in Figure 6. "Electrical Connections."
- Reverse Acting Calibration-Zero
  6. Apply the minimum input signal and adjust the Zero screw for maximum output pressure. Turn screw counterclockwise to increase pressure and clockwise to decrease pressure.
- Reverse Acting Calibration-Span
  7. Apply the maximum input signal and adjust the Span screw on the potentiometer for minimum output pressure. Turn screw counterclockwise to increase pressure and clockwise to decrease pressure.
  8. Repeat steps 6-7 until the desired output range is obtained. For more information, see Figure 8. "T5200/ TXPD5200 Calibration Configuration."

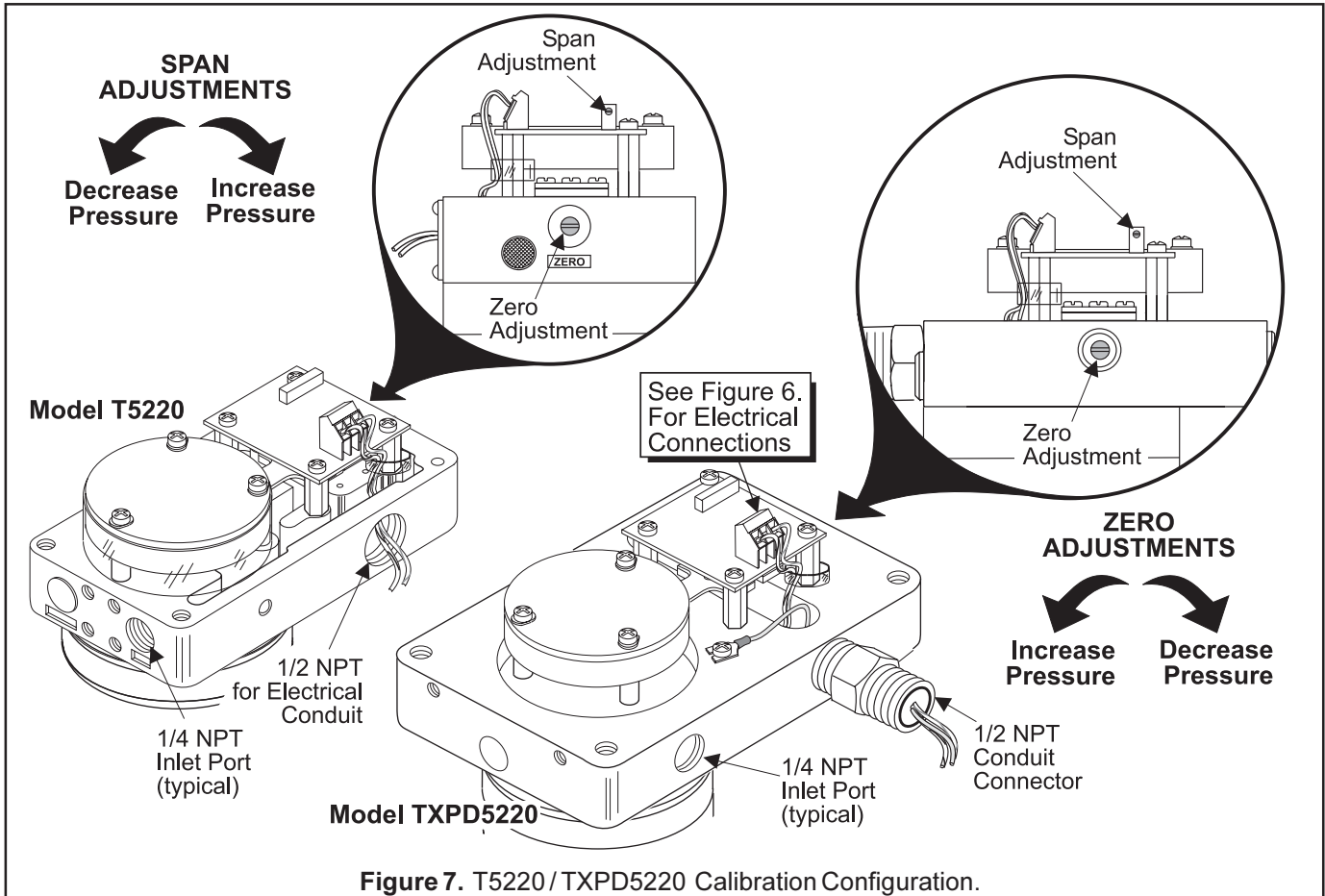

Figure 7. T5220 / TXPD5220 Calibration Configuration.

## MAINTENANCE

To clean the Orifice, use the following procedure:

1. Turn off the air supply to the transducer. If the transducer is a common supply unit, remove the Pipe Plug from the In Port located on the rectangular base. If the transducer is a separate supply unit, remove the Air Line Fitting from the In Port.
2. Remove the Orifice Assembly (9) from the unit by threading a 1/4-20" Screw into the orifice housing and pulling it out through the inlet port. For more information, see Figure 8. "Exploded Drawing" below.
3. Clean with alcohol and dry with compressed air.

**NOTE: Parts must be completely dry before reassembling.**

To clean the Inner Valve Assembly, use the following procedure:

1. Shut off the valve that is supplying air to transducer. **It is not necessary to remove the Transducer from air line.**
2. Remove Screws (7) holding the Retainer Cap (6) and Plate (5) to Booster (1).
3. Pull out Inner Valve Assembly (4) and wash the seat carefully.
4. Wipe off any particles that may be attached to rubber Seat Ring Assembly (2). For more information, see Detail A, below.

**NOTE: Avoid such solvents as acetone, carbon tetrachloride and trichlorethylene.**

To clear problems caused by Magnet malfunction, use the following procedure:

1. Shut off the valve that is supplying air to transducer. **It is not necessary to remove the Transducer from air line.**
2. Remove three Screws (12) holding Magnet (11) to Transducer (8).
3. Remove Magnet (11) and clean gap of any foreign material with masking tape. For more information, see View B, below.
4. Place Magnet (11) over Coil (10) and tighten with three Screws (12).
5. Using a non-metallic rod, Raise up on the arm to make sure Coil (10) is not sticking in Magnet (11).

**NOTE: If Coil is sticking, loosen Screws and reposition Magnet. Tighten Screws and repeat step 5.**

To replace PC Board, use the following procedure:

1. Disconnect wires from Terminal Block on PC Board (14).
2. Unsolder Red (+) and Black (-) Leads on PC Board (14).
3. Remove four Screws (13) holding PC Board (14) to Transducer (8). For more information, see Figure 8. "Exploded Drawing" below.
4. Replace PC Board (14) with the appropriate PC Board from Table 3. on page 7.

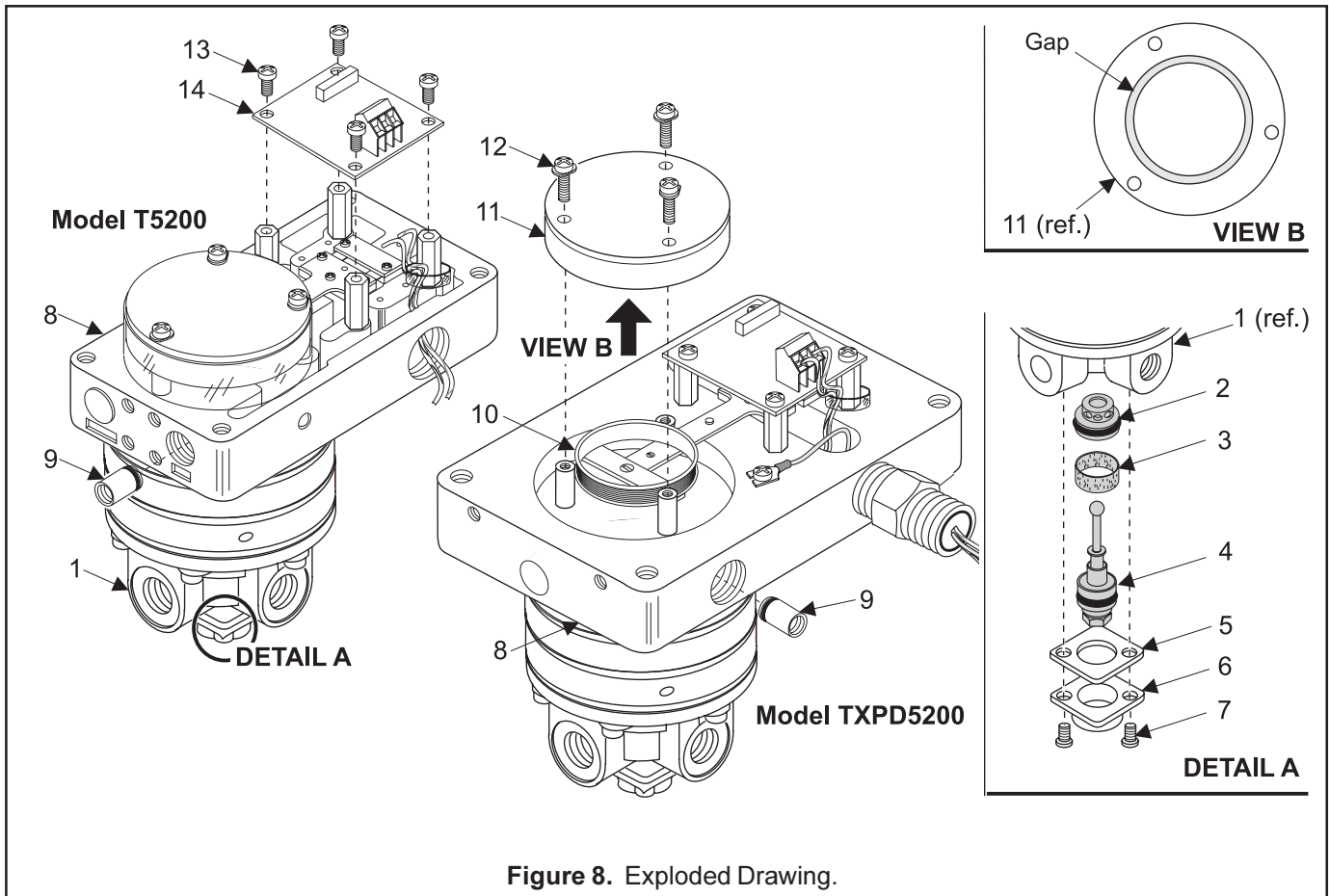

Figure 8. Exploded Drawing.

**Maintenance (continued)**

Item	Qty.	Part No.	Description
1	1	NS	Transducer
2	1	NS	Orifice
3	1	NS	Coil
4	1	NS	Magnet
5	1	NS	Screw
6	1	NS	Screw
7	2	NS	Booster
8	1	NS	Seat Ring Assembly
9	1	NS	Screen
10	4	NS	Inner Valve Assembly
11	1	NS	Retainer Plate
12	1	NS	Retainer Cap
13	1	NS	Screw
14	1	13744-2 <sup>1</sup>	1-5 mA PC Board
14	1	15638-2 <sup>2</sup>	1-5 mA PC Board
14	1	13745-2 <sup>1</sup>	4-20,10-50 mA PC Board
14	1	15483-2 <sup>2</sup>	4-20,10-50 mA PC Board
14	1	14639-2 <sup>1</sup>	1-5 VDC PC Board
14	3	15640-2 <sup>2</sup>	1-5 VDC PC Board
14	1	13746-2 <sup>1</sup>	1-9 VDC PC Board
14	1	15639-2 <sup>2</sup>	1-9 VDC PC Board

<sup>1</sup> For T5220, TFI5220, TFN5220, TFNI5220, TXPD5220, & TXPDI5220 Units Only.

<sup>2</sup> For TCI5220 Only.

**NS:** (Not Serviceable) In the Part No. column, NS indicates that the part is not available for field replacement.

**TROUBLE-SHOOTING**

Problem	Solution (check)
No Output	Supply Pressure Clogged Orifice Power Supply
Leakage	Pneumatic Connections
Low or Improper Span Adjust	Zero and Span Adjust Supply Pressure Low Output Leakage
Erratic Operation	DC Signal Loose Wires or Connections Liquid in Air Supply Dirt in Magnet Gap
Unit Does Not Operate	Replace PC Board

**NOTE: Booster Repair Kits are available for the T5220.**

Ratio	Kit Number
1:1	15288-1
1:2	15288-2
1:3	15288-3
1:4	15656-4
1:5	15656-5
1:6	15656-6





ISO 9001:2000  
FM NO. 25571

**ISO 9001:2000  
Certified**

Fairchild Industrial Products Company  
3920 West Point Blvd • Winston-Salem, NC 27103  
phone: (336) 659-3400 • fax: (336) 659-9323  
sales@fairchildproducts.com • www.fairchildproducts.com

 **FAIRCHILD**  
*precision pneumatic & motion control*

IS-500T5220  
Litho in USA  
Rev. M 06/07