

FINE CONTROLS (UK) LTD



Fine Controls have been supplying process controls & instrumentation equipment since 1994, & now serves an ever expanding customer base, both in the UK & globally.

We offer a full range of valve & instrumentation products & services, with our product range representing leading technologies & brands:

Flow: Flow Meters & Transmitters, Flow Switches, Flow Control Valves & Batch Control Systems

Temperature: Temperature Probes & Thermowells, Temperature transmitters, Temperature Regulators & Temperature Displays

Level: Level Transmitters & Switches

Pressure: Pressure Gauges & Transmitters, Precision & High Pressure Regulators & I-P Converters, Volume boosters.

Precision Pneumatics: Pressure Regulators, I-P Converters, Volume Boosters, Vacuum Regulators

Valves: Solenoid & Pneumatic Valves, Control Valves & Positioners, Actuated Ball, Globe or Diaphragm Valves & Isolation Valves

Services: Repair, Calibration, Panel Build, System Design & Commissioning

A rotork® Brand
FAIRCHILD



bürkert



SIEMENS



alcon
SOLENOID VALVES

A rotork® Brand



MIDLAND-ACS
A rotork® Brand



Honeywell



Bourdon
Baumer Group



SOLDO
CONTROLS

A rotork® Brand



Fine Controls (UK) LTD, Bassendale Road, Croft Business Park,
Bromborough, Wirral, CH62 3QL UK
Tel: 0151 343 9966
Email: sales@finecontrols.com

Type 861 1 eCONTROL

Process controller and Ratio controller

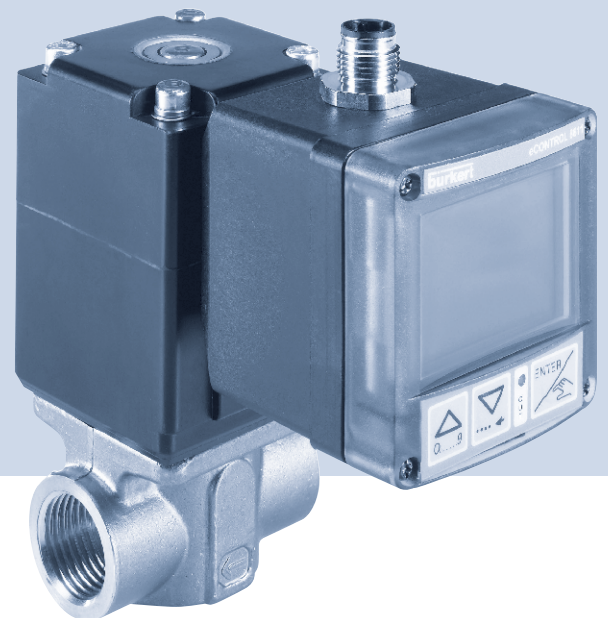
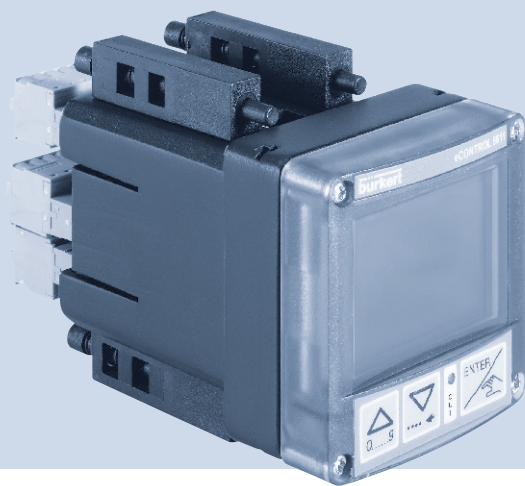

Operating Instructions

(Valid from software version B01)

We reserve the right to make technical changes without notice.
Technische Änderungen vorbehalten.
Sous réserve de modification techniques.

© 2009 - 2011 Bürkert Werke GmbH

Operating Instructions 1101/03_EUen_00805625 / Original: DE

eCONTROL 8611: Process Controller and Ratio Controller

CONTENTS

| | | |
|-----------|---|-----------|
| 1. | OPERATING INSTRUCTIONS..... | 6 |
| 1.1. | Symbols..... | 6 |
| 2. | AUTHORIZED USE | 7 |
| 2.1. | Restrictions..... | 7 |
| 2.2. | Predictable Misuse..... | 7 |
| 3. | BASIC SAFETY INSTRUCTIONS..... | 8 |
| 4. | GENERAL INFORMATION..... | 9 |
| 4.1. | Contact Addresses..... | 9 |
| 4.2. | Warranty | 9 |
| 4.3. | Information on the Internet..... | 9 |
| 5. | SYSTEM DESCRIPTION | 10 |
| 5.1. | General Description..... | 10 |
| 5.2. | Functions | 11 |
| 5.3. | The various mounting and installation models..... | 11 |
| 5.4. | Software..... | 11 |
| 6. | TECHNICAL DATA..... | 12 |
| 6.1. | Operating Conditions..... | 12 |
| 6.2. | Conformity with the following standards | 12 |
| 6.3. | General Technical Data..... | 12 |
| 6.4. | Rating plate description..... | 13 |
| 6.5. | Electrical Data..... | 14 |
| 7. | ASSEMBLY | 16 |
| 7.1. | Assembly models..... | 16 |
| 7.2. | Attachment to a proportional valve | 17 |
| 7.3. | Assembly of the control cabinet model | 18 |

| | | |
|------------|--|-----------|
| 8. | ELECTRICAL INSTALLATION | 20 |
| 8.1. | Electrical installation for fitting assembly, wall assembly, valve assembly or rail assembly models..... | 20 |
| 8.2. | Electrical installation of the control cabinet model..... | 24 |
| 9. | OPERATION AND FUNCTION | 27 |
| 9.1. | Control and display elements..... | 27 |
| 9.2. | Operating levels and operating states..... | 28 |
| 9.3. | Function of the keys..... | 29 |
| 10. | OPERATING STRUCTURE | 30 |
| 10.1. | Operating structure of the process operating level in MANUAL operating state..... | 30 |
| 10.2. | Operating structure of the configuration level..... | 31 |
| 11. | FUNCTIONS OF THE PROCESS OPERATING LEVEL | 37 |
| 11.1. | Operating state AUTOMATIC..... | 37 |
| 11.2. | Operating state MANUAL..... | 38 |
| 11.3. | Specific menu options of process and ratio control..... | 38 |
| 11.4. | Menu options in the MANUAL operating state..... | 38 |
| 11.5. | SET - Set-point value default for process control..... | 39 |
| 11.6. | RFAC - Ratio factor default for ratio control..... | 39 |
| 11.7. | TEST – Display of the analog inputs and outputs and the digital inputs..... | 40 |
| 11.8. | PARA – Display and optimization of the controller parameters..... | 41 |
| 11.9. | VALV – Manual opening and closing of the connected actuating elements..... | 42 |
| 12. | FUNCTIONS OF THE CONFIGURATION LEVEL | 44 |
| 12.1. | General Description..... | 44 |
| 12.2. | Menu options of the configuration level..... | 45 |
| 12.3. | MODE - Selection of control variable, actuating element and process value input..... | 46 |
| 12.4. | UNIT - Selection of measuring units and decimal places..... | 59 |
| 12.5. | SETP / RFAC - Selection and scaling of set-point value default / entry of ratio factor..... | 62 |
| 12.6. | S_IN - Scaling of sensor input signal (4 - 20 mA or 0 - 10 V)..... | 64 |

| | | |
|--------|--|----|
| 12.7. | AOUT - Scaling of analog output(4 - 20 mA or 0 - 10 V) | 65 |
| 12.8. | CALI - Calibration of the analog inputs and outputs | 67 |
| 12.9. | Calibration of the assembly models: Wall, rail, valve or fitting assembly..... | 68 |
| 12.10. | Calibration of the control cabinet model..... | 69 |
| 12.11. | KFAC - Entry of K-factor for flow-rate measurement..... | 70 |
| 12.12. | FILT - Filtering of the process actual value input..... | 72 |
| 12.13. | PARA - Adjusting the controller parameters..... | 73 |
| 12.14. | B_IN - Configuration of binary input..... | 81 |
| 12.15. | B_O1 - Configuration of the binary output..... | 82 |
| 12.16. | B_O2 - Second binary output..... | 90 |
| 12.17. | VALV - Test function and setting of the control range | 91 |
| 12.18. | CODE - Code protection | 93 |
| 12.19. | DSPL - Setting the display..... | 94 |
| 12.20. | FACT - Reset to Factory Settings | 95 |
| 12.21. | U_xx, B_xx - Display of the program version and software version..... | 95 |
| 12.22. | END - Leaving the configuration level | 96 |
| 13. | OVERVIEW SETTING PARAMETERS..... | 97 |
| 14. | MAINTENANCE, TROUBLESHOOTING..... | 98 |
| 14.1. | Malfunctions..... | 98 |
| 15. | PACKAGING AND TRANSPORT | 99 |
| 16. | STORAGE..... | 99 |
| 17. | DISPOSAL | 99 |

1. OPERATING INSTRUCTIONS

The operating instructions describe the entire life cycle of the device. Keep these instructions in a location which is easily accessible to every user, and make these instructions available to every new owner of the device.



WARNING!

The operating instructions contain important safety information!

Failure to observe these instructions may result in hazardous situations.

- The operating instructions must be read and understood.

1.1. Symbols



DANGER!

Warns of an immediate danger!

- Failure to observe the warning will result in a fatal or serious injury.



WARNING!

Warns of a potentially dangerous situation!

- Failure to observe the warning may result in serious injuries or death.



CAUTION!

Warns of a possible danger!

- Failure to observe this warning may result in a moderate or minor injury.

NOTE!

Warns of damage to property!

- Failure to observe the warning may result in damage to the device or the equipment.



Indicates important additional information, tips and recommendations.



refers to information in these operating instructions or in other documentation.

→ designates a procedure which you must carry out.

2. AUTHORIZED USE

Non-authorized use of the process controller Type 8611 may be a hazard to people, nearby equipment and the environment.

- The process controller is intended for controlling the process variables for pressure, temperature or flow-rate in conjunction with a proportional or process valve and a sensor.
- Do not use the device outdoors.
- Use according to the authorized data, operating conditions and conditions of use specified in the contract documents and operating instructions. These are described in the chapter entitled "Technical Data".
- The device may be used only in conjunction with third-party devices and components recommended and authorized by Bürkert.
- Correct transportation, correct storage and installation and careful use and maintenance are essential for reliable and faultless operation.
- Use the device only as intended.

2.1. Restrictions

If exporting the system/device, observe any existing restrictions.

2.2. Predictable Misuse

- The Type 8611 is not to be used in areas where there is a risk of explosion.
- Do not physically stress the housing (e.g. by placing objects on it or standing on it).

3. BASIC SAFETY INSTRUCTIONS

These safety instructions do not make allowance for any

- contingencies and events which may arise during the installation, operation and maintenance of the devices.
- local safety regulations – the operator is responsible for observing these regulations, also with reference to the installation personnel.



General Hazardous Situations.

To prevent injury, ensure that:

- any installation work may be carried out by authorized technicians and with the appropriate tools only.
- after an interruption in the power supply or pneumatic supply, ensure that the process is restarted in a defined or controlled manner.
- the device may be operated only when in perfect condition and in consideration of the operating instructions.
- the general rules of technology apply to application planning and operation of the device.

NOTE!

Electrostatic sensitive components / modules!

The device contains electronic components, which react sensitively to electrostatic discharge (ESD). Contact with electrostatically charged persons or objects is hazardous to these components. In the worst case scenario, they will be destroyed immediately or will fail after start-up.

- Observe the requirements in accordance with EN 61340-5-1 and 5-2 to minimize or avoid the possibility of damage caused by sudden electrostatic discharge!
- Also, ensure that you do not touch electronic components when the power supply voltage is present!



The process controller Type 8611 was developed with due consideration given to the accepted safety rules and is state-of-the-art. Nevertheless, dangerous situations may occur.

Failure to observe this operating manual and its operating instructions as well as unauthorized tampering with the device release us from any liability and also invalidate the warranty covering the devices and accessories!

4. GENERAL INFORMATION

4.1. Contact Addresses

Germany

Bürkert Fluid Control Systems
Sales Center
Christian-Bürkert-Str. 13-17
D-74653 Ingelfingen
Tel. + 49 (0) 7940 - 10 91 111
Fax + 49 (0) 7940 - 10 91 448
E-mail: info@de.buerkert.com

International

Contact addresses can be found on the final pages of the printed operating instructions.

And also on the Internet at:

www.burkert.com

4.2. Warranty

The warranty is only valid if the device is used as intended in accordance with the specified application conditions.

4.3. Information on the Internet

The operating instructions and data sheets for Type 8611 can be found on the Internet at:

www.burkert.com

5. SYSTEM DESCRIPTION

5.1. General Description

The process controller Type 8611 is designed for integration in a closed control circuit and can be used for numerous control tasks in fluid technology. The figure below illustrates the integration of the controller in a closed control circuit.

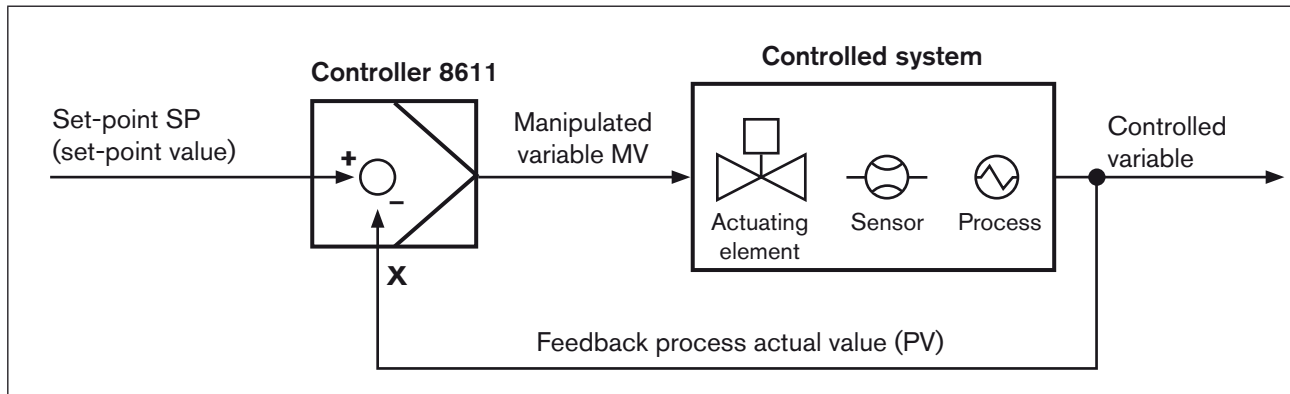

Figure 1: Block diagram of a closed control circuit

5.1.1. Interfaces of the process controller Type 8611

Depending on the controlled system and process, different controller structures and different inputs/outputs are available for measuring the process actual value and for controlling the actuating elements. The diagram below shows the available interfaces of the process controller.

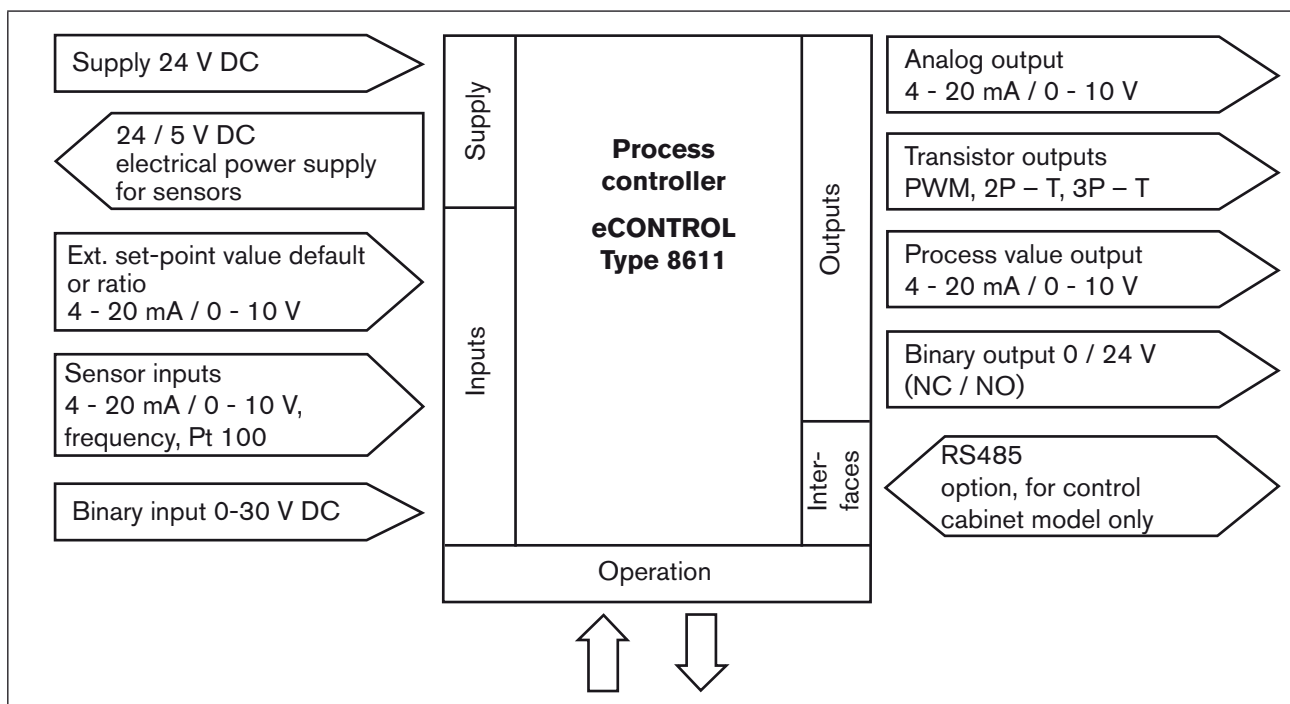

Figure 2: Interfaces of the process controller Type 8611

5.2. Functions

The following control tasks can be executed with the process controller Type 8611 eCONTROL.

- Fixed command control (single-loop control circuit)
- Sequential control (external set-point value)
- Ratio control
- Cascade control

Standard signals (current / voltage) and frequency-analog signals can optionally be applied or resistance thermometers (Pt 100) can be connected to the scalable controller inputs.

Outputs for continuous standard signals (current / voltage) or transistor outputs can be used as controller outputs. Valves or other switching actuators can be operated via the transistor outputs. One binary output and up to 2 binary outputs for auxiliary functions are additionally provided.

5.3. The various mounting and installation models

The process controller Type 8611 is available in the following models (see also chapter 7.1. *Assembly models*):

- For installation in a pipeline system
- For attachment to a proportional valve
- For wall assembly or for assembly on a rail
- For installation in a control cabinet



Particularities of the control cabinet model:

Unlike the remaining assembly models, the cabinet model of type 8611 has not one but two binary outputs.

5.4. Software

In the following description of the menu options and their operating structures, the entire software of the eCONTROL Type 8611 is explained. This complete software scope is only available for the control cabinet model of the eCONTROL Type 8611.

The menu structure may vary depending on the device model (wall, valve, rail or fitting assembly). In accordance with the device model, only menu options that are logically purposeful for the application area can be selected. This pre-selection is made upon delivery of the controller in accordance with the chosen order part number.

6. TECHNICAL DATA

6.1. Operating Conditions

| | |
|---|------------------------|
| Permitted ambient temperature: (operation and storage) | 0 ... +70 °C |
| Max. permitted humidity: | ≤ 80 %, non condensing |
| Protection class: | IP65 to EN 60529 |

6.2. Conformity with the following standards

| | |
|---------------------------------------|---------|
| CE mark conforms to EMC Directive: | EN61326 |
|---------------------------------------|---------|

6.3. General Technical Data

Materials

| | |
|------------------------|------------------------|
| Housing, cover: | PC, + 20 % glass fiber |
| Front plate foil: | Polyester |
| Screws: | Stainless steel |
| Multipin: | CuZn, nickel-plated |
| Wall assembly bracket: | PVC |

Assembly

| | |
|------------------------|---|
| Installation position: | Any position |
| Assembly models: | Attachment to a pipeline with Bürkert flow-rate fitting Type S030 wall assembly, rail assembly, valve assembly, control cabinet assembly |
| Display: | 2-line, (see <i>Figure 10: Display elements</i>) |
| Operating voltage: | Multipin: 3-pin or / and 4-pin M8, 8-pin M12 |
| Power cable: | 0.5 mm ² max. cross section, max. 100 m long, screened |

6.4. Rating plate description

The rating plate contains important technical data for the specific device. The structure of the rating plate is described below by way of example.

6.4.1. Rating plate of the controllers for wall, rail, valve or fitting assembly

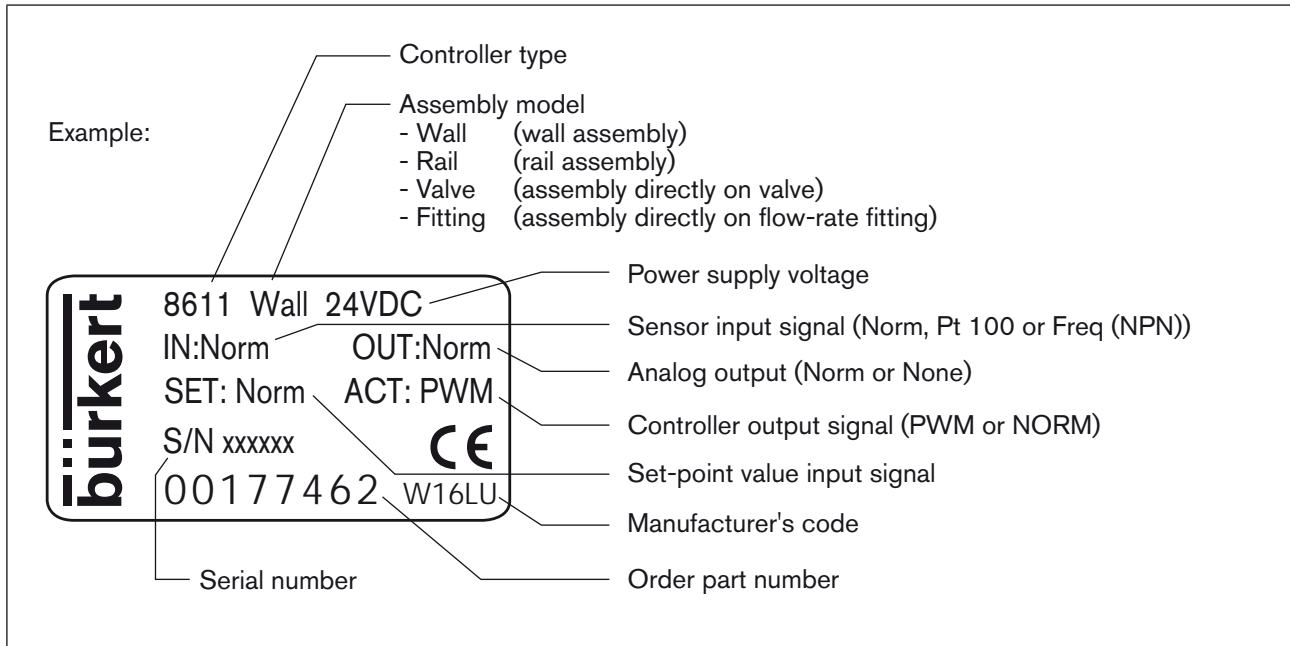

Figure 3: Example: Rating plate of the controllers for wall, rail, valve or fitting assembly

6.4.2. Rating plate of the control cabinet model

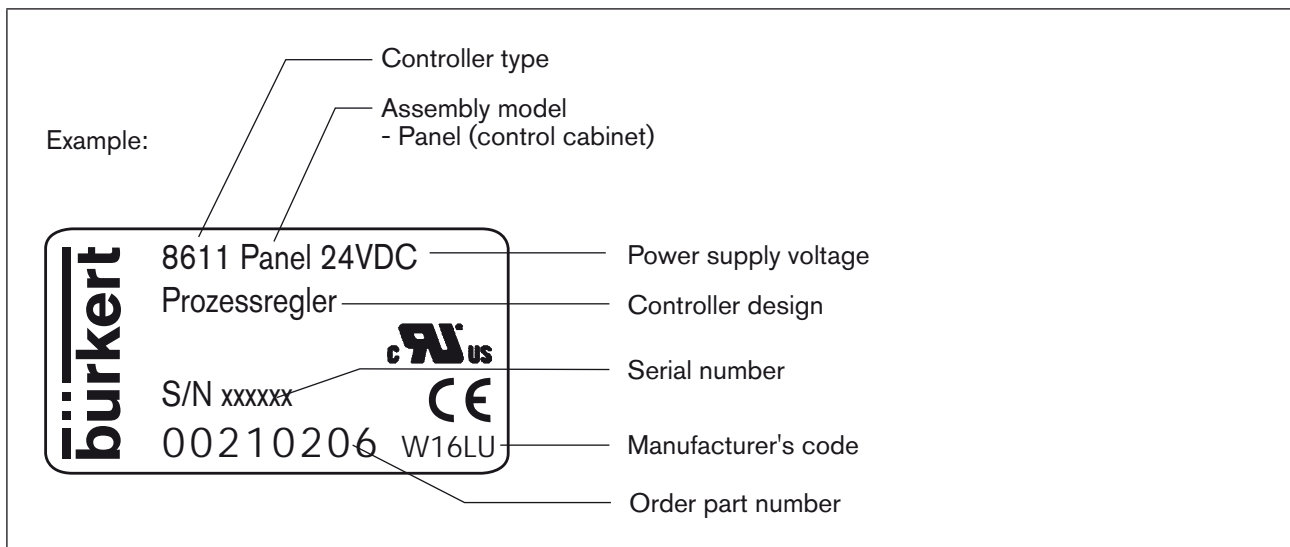

Figure 4: Example: Rating plate of the control cabinet model

6.5. Electrical Data

| | |
|---------------------------|--|
| Operating voltage: | 24 V DC \pm 10 %, filtered and controlled |
| Power consumption | without load: approx. 2 W with load: maximum 48 W 100 % ED: 36 W |
| Controller sampling rate: | 300 Hz |

6.5.1. Inputs

Set-point value

| | | |
|--------------------|------------------|-----------------|
| Standard 4 - 20 mA | Input impedance: | 70 Ω |
| | Resolution: | 5.5 μ A |
| Standard 0 - 10 V | Input impedance: | 11.5 k Ω |
| | Resolution: | 2,5 mV |

Sensors

| | | |
|--------------------|------------------|-------------|
| Standard 4 - 20 mA | Input impedance: | 70 Ω |
| | Resolution: | 5.5 μ A |

Frequency

| | | |
|-----------------|----------------------|--|
| Input 1 | External sensor | |
| | Frequency range: | min. 0.25 Hz / max. 1 kHz |
| | Input resistance: | > 1 k Ω |
| | Signal types: | Sine, rectangle, triangle (> 3000 mVss, max. 30 Vss) |
| Input 2 | Internal Hall sensor | |
| | Frequency range: | min. 0.25 Hz / max. 1 kHz (only in conjunction with Bürkert flow-rate fitting Type S030) |
| Pt 100 (2-wire) | Measuring range: | 0 $^{\circ}$ C ... 200 $^{\circ}$ C |
| | Measured current: | 1 mA |
| | Measuring error: | < 0.5 $^{\circ}$ C |

Binary input

| | |
|---------------------|---------------|
| Input impedance: | 10 k Ω |
| Response threshold: | 3 ... 30 V |
| Max. frequency: | 1 kHz |

6.5.2. Outputs

| | |
|------------------------------------|--|
| Continuous signal | Standard signal 4 - 20 mA |
| | Max. loop resistance: 680 Ω Precision: 0,5 % |
| | Standard signal 0 - 10 V |
| | Maximum current: 20 mA Precision: 0,5 % |
| Discontinuous signal | 2 transistor outputs for PWM or PTM control |
| | Control frequency: 1.2 kHz ... 20 Hz |
| | Max. resolution: 16 bit (depending on frequency) |
| | Max. current per unit area: 1.5 A |
| Binary output | Switching voltage: 24 V DC |
| | Transistor output (PNP) configurable |
| | Max. current per unit area: 1.5 A |
| Sensor supply: | Switching voltage: 24 V DC |
| | 24 V DC |
| Total load for all outputs: | 1,5 A |

7. ASSEMBLY

7.1. Assembly models

| Attachment to a Bürkert flow-rate fitting | Attachment to a proportional valve |
|--|--|
|  <p>Bürkert flow-rate fitting Type SO30</p> |  |
| Installation in a control cabinet | Wall assembly or rail assembly |
|  <p>The description of the installation in a control cabinet and the device dimensions can be found in the following chapter 7.3. <i>Assembly of the control cabinet model.</i></p> |  <p>Adapter for wall assembly</p> <p>Adapter for rail assembly</p> |

Table 1: Assembly models

7.1.1. Assembly accessories

| Model | Accessories | Order no. |
|--------------------------|------------------------------|---------------------|
| Installation in pipeline | Flow-rate fitting, Type S030 | See data sheet S030 |
| Rail assembly | Adapter for rail assembly | 655980 |
| Wall assembly | Adapter for wall assembly | 427098 |

The adapters for the wall and rail assembly are included in the scope of supply of the assembly model.

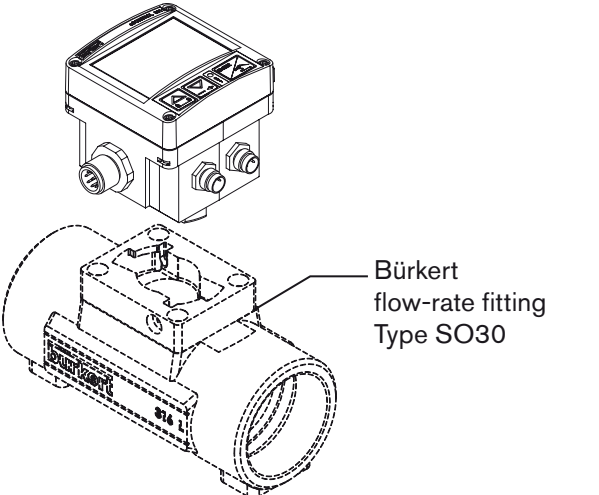
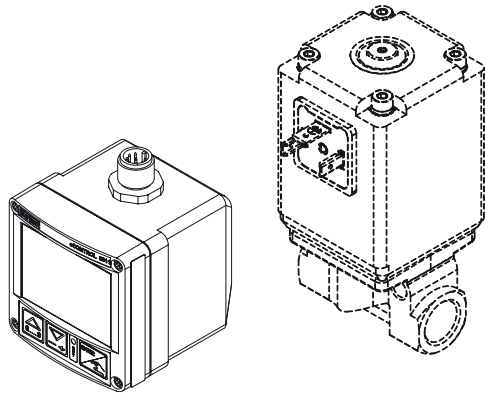
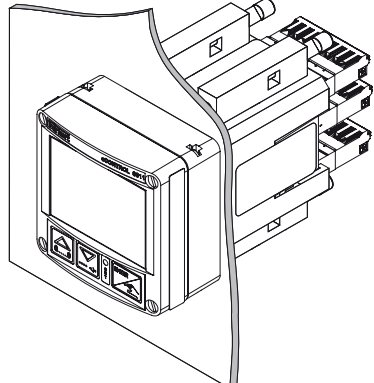
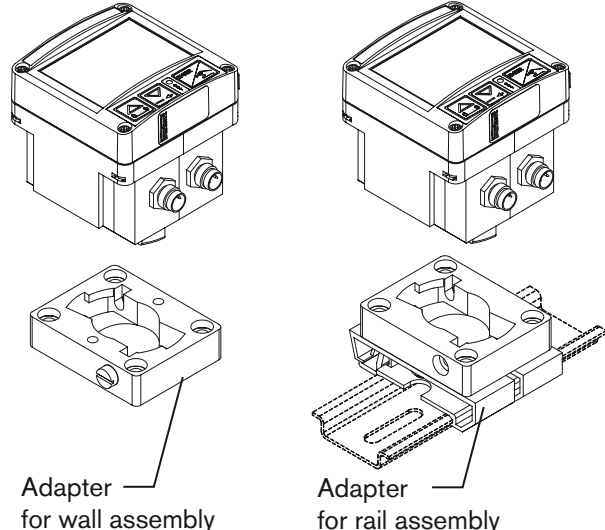
Table 2: Assembly accessories

7.2. Attachment to a proportional valve

Attach the process controller Type 8611 to a proportional valve as described below.

→ Loosen the 4 screws at the front of the process controller.

NOTE!

Be careful when opening the process controller so as not to damage the internal cabling.

- Remove the cover carefully from the housing without jerks.

→ Remove the cover carefully from the housing.

→ Place the supplied flat seal over the contact tabs.

→ Attach the housing of the process controller on the contact tabs and fasten with the valve screw.

→ Check the correct position of the profile gasket at the housing of the process controller.

→ Place cover on the housing of the process controller and fasten with 4 screws.



If necessary, the cover can also be mounted in a position rotated by 90 ° to the left or the right.

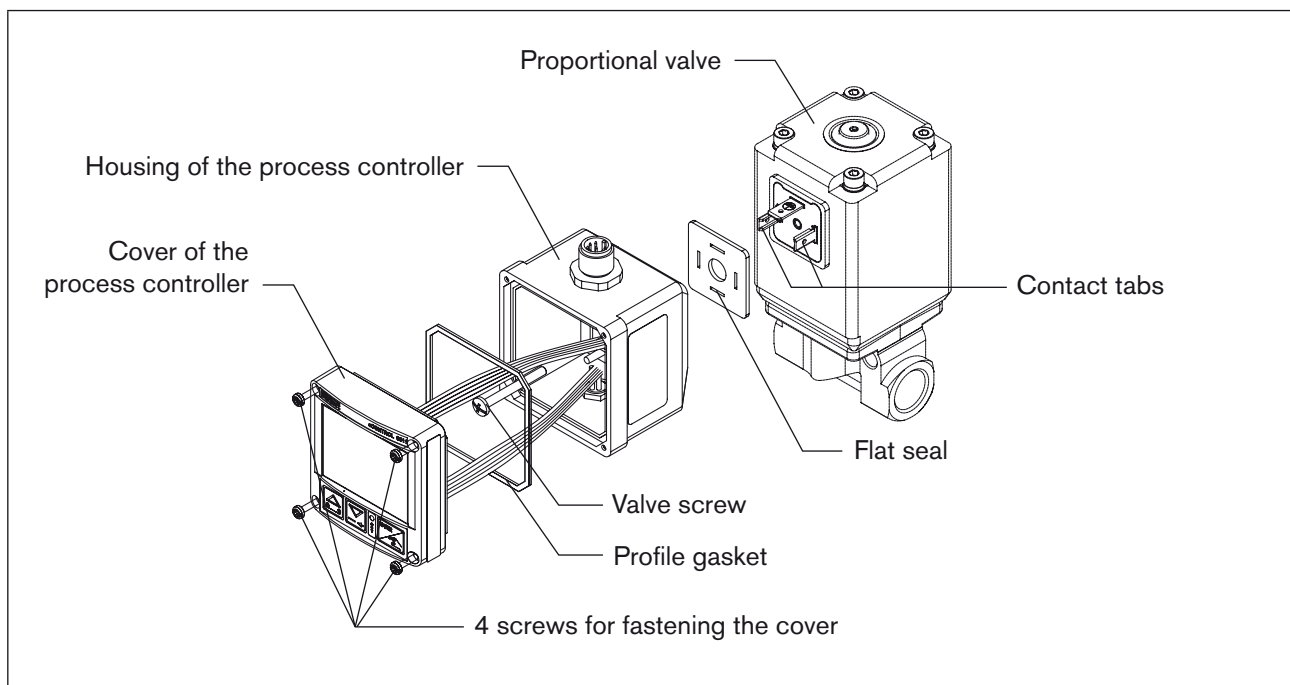

Figure 5: Attachment of the process controller to a proportional valve

7.3. Assembly of the control cabinet model

7.3.1. Device dimensions and control panel cut-out

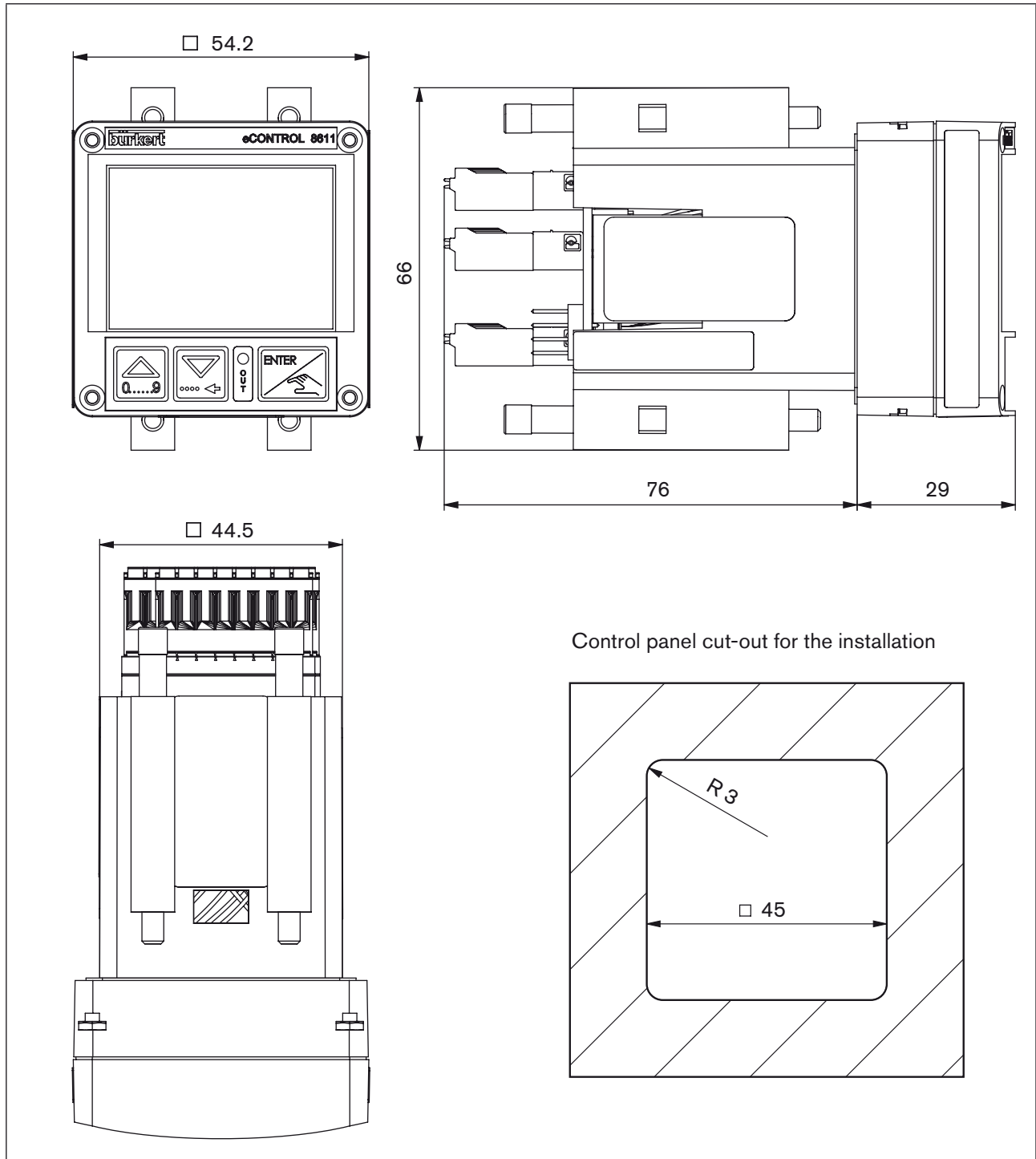

Figure 6: Device dimensions and control panel cut-out

7.3.2. Installation in a control cabinet

- Prepare control panel cut-out with the dimensions 45mm x 45mm (corner radius 3mm).
- Place the supplied seal on the housing.
- Insert the controller from the front into the control panel cut-out.
- From the rear, snap the 4 supplied fastening elements into place and fasten using a screwdriver.

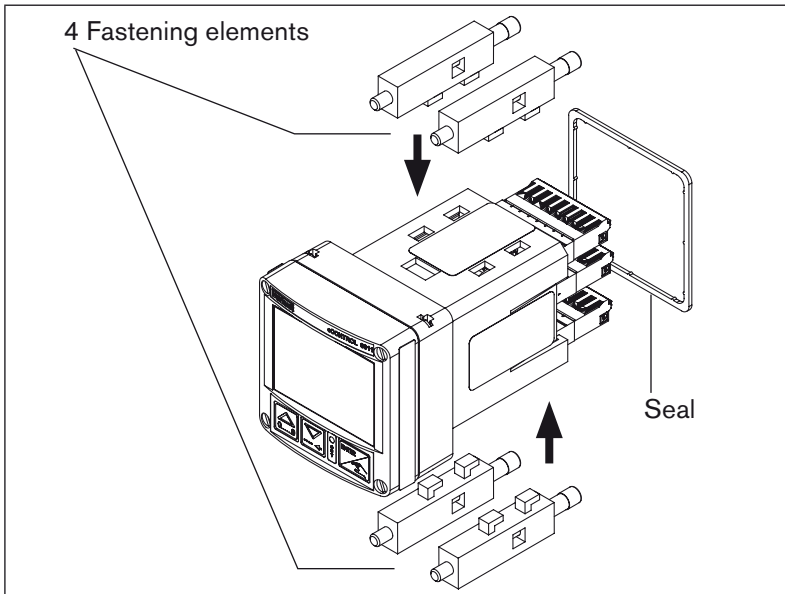

Figure 7: Installation elements

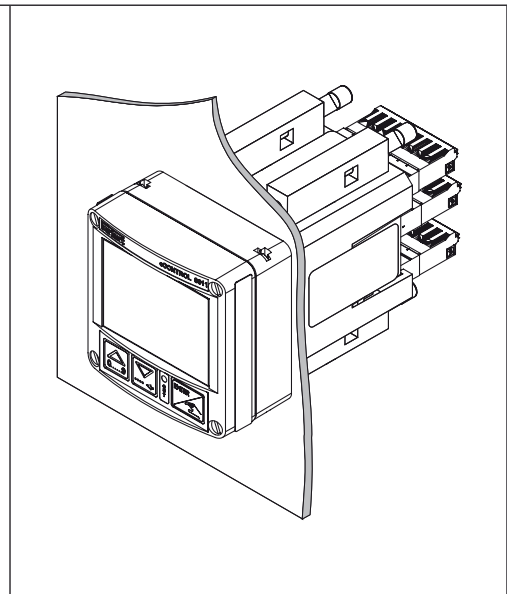

Figure 8: Installed controller

Recommended line cross sections for the control cabinet model:

| | Cross section min. | Cross section max. | Minimum length |
|---|----------------------|----------------------|-------------------|
| Cross section for flexible lines | 0.2 mm ² | 1.5 mm ² | 10 mm (stripping) |
| Cross section for flexible lines with cable end sleeve without plastic sleeve | 0.25 mm ² | 1.5 mm ² | 10 mm |
| Cross section for flexible lines with cable end sleeve with plastic sleeve | 0.25 mm ² | 0.75 mm ² | 10 mm |

Table 3: Recommended line cross sections

8. ELECTRICAL INSTALLATION

8.1. Electrical installation for fitting assembly, wall assembly, valve assembly or rail assembly models

8.1.1. Connection versions



| Connector | Connector view | Configuration |
|---|---|--|
| Circular plug-in connector M12, 8-pole |  | Power supply voltage, set-point input 4 - 20 mA / 0 - 10 V, process actual value or position set-point output 4 - 20 mA / 0 - 10 V, binary input, binary output Note! A straight plug (female) is recommended for the connecting cable, as the alignment of the plug can vary. |
| Circular plug-in connector M8, 3-pole |  | Connection sensor (4 - 20 mA / 0 - 10 V, Pt 100 or frequency) and sensor supply 24 V DC |
| Circular plug-in connector M8, 4-pole |  | Connection actuating element <ul style="list-style-type: none"> ▪ Proportional valve (1 x PWM) ▪ Process valve (1 x PTM) ▪ Manipulated variable 4 - 20 mA / 0 - 10 V and sensor supply 24 V DC (only ID 182383) |
| DIN-EN 175301 |  | Connection for direct assembly on proportional valve (1 x PWM) or open/closed valve (1 x PTM) |

Table 4: Connection versions for assembly on flow-rate fitting, wall assembly, rail assembly or valve assembly

8.1.2. Pin assignment

Circular plug-in connector M12, 8-pole

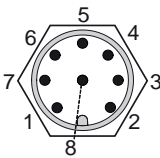

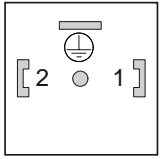
A straight connector (female) is recommended for the connecting cable as the orientation of the connector may vary.

| Connector diagram | Pin | Color | Configuration |
|-------------------|----------|--------|---|
| | 1 | white | 24 V DC power supply |
| | 2 (DIN2) | brown | Binary input (B_IN) |
| | 3 | green | GND – Power supply, binary input, binary output |
| | 4 (AOUT) | yellow | 4 - 20 mA or 0 - 10 V analog output (process value or manipulated variable for valve) |
| | 5 (AIN2) | grey | 4 - 20 mA or 0 - 10 V analog input (set-point value / ratio) |
| | 6 | pink | GND – Analog output |
| | 7 | blue | GND – Analog input (set-point value / ratio) |
| | 8 (BO1) | red | (+) Binary output (B_O1) |

Table 5: Configuration of circular plug-in connector M12, 8-pole



Wire colors when using standard cables (e.g. from Lumberg, Escha)

8.1.3. Sensor connection

Circular plug-in connector M8, 3-pole



| Input signal | Pin | Color | Configuration | External circuit |
|---|-----|-------|-----------------------|------------------|
| 4 - 20 mA 2-wire supply of Type 8611 (AIN1) | 1 | brown | + 24 V sensor supply | |
| | 3 | blue | not connected | |
| | 4 | black | Signal input (source) | |
| 4 - 20 mA / 0 - 10 V 3-wire supply of Type 8611 (AIN1) | 1 | brown | + 24 V sensor supply | |
| | 3 | blue | GND | |
| | 4 | black | Signal input (source) | |
| 4 - 20 mA / 0- 10 V 4-wire external supply (AIN1) | 1 | brown | not connected | |
| | 3 | blue | GND | |
| | 4 | black | Signal input (source) | |

| Input signal | Pin | Color | Configuration | External circuit |
|--|-----|-------|---------------------------|------------------|
| Frequency 3-wire supply of Type 8611 (DIN1) | 1 | brown | + 24 V sensor supply | |
| | 3 | blue | GND | |
| | 4 | black | Frequency input (NPN) | |
| Frequency 4-wire external supply (DIN1) | 1 | brown | not connected | |
| | 3 | blue | GND | |
| | 4 | black | Frequency input (NPN) | |
| Pt 100 (2-wire) (AIN3) | 1 | brown | not connected | |
| | 3 | blue | GND Pt 100 | |
| | 4 | black | (+) Pt 100 (power supply) | |

Table 6: Sensor connection: Configuration of circular plug-in connector M8, 3-pole

8.1.4. Valves connection

Circular plug-in connector M8, 4-pole

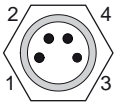

| Output signal: | Pin | Color | Configuration | External circuit |
|---|----------|-------|---|------------------|
| PWM (MODE = SCV) | 1 | brown | not connected | |
| | 2 | white | not connected | |
| | 3 | blue | (-) PWM (valve2) | |
| | 4 (BO4) | black | (+) PWM (valve2) | |
| 3-point (MODE = PCV) | 1 (BO3) | brown | (+) Aeration (valve 1) | |
| | 2 | white | (-) Aeration (valve 1) | |
| | 3 | blue | (-) Deaeration (valve 2) | |
| | 4 (BO4) | black | (+) Deaeration (valve 2) | |
| 1) 4 - 20 mA or 0 - 10 V (MODE = 4 - 20 / 0 - 10) | 1 (BO3) | brown | + 24 V DC supply | |
| | 2 | white | GND (4 - 20 mA or 0 - 10 V) | |
| | 3 | blue | GND supply | |
| | 4 (AOUT) | black | + 4 - 20 mA or 0 - 10 V manipulated variable | |

| Output signal: | Pin | Color | Configuration | External circuit |
|--|----------|-------|--|------------------|
| 3-point (MODE = 3P - T) | 1 (BO3) | brown | (+) Valve 1 | |
| | 2 | white | (-) Valve 1 | |
| | 3 | blue | (-) Valve 2 | |
| | 4 (BO4) | black | (+) Valve 2 | |
| 1) 4 - 20 mA or 0 - 10 V (MODE = 4 - 20 / 0 - 10) External supply | 1 | brown | + 24 V DC supply (max. 1A) | |
| | 2 | white | GND (4 - 20 mA or 0 - 10 V) | |
| | 3 | blue | GND supply | |
| | 4 (AOUT) | black | + 4 - 20 mA or 0 - 10 V manipulated variable | |
| 2-point (MODE = 2P - T) | 1 (BO3) | brown | (+) Valve 1 | |
| | 2 | white | (-) Valve 1 | |
| | 3 | blue | not connected | |
| | 4 | black | not connected | |

1) Only available for identification number 182383

Table 7: Configuration of circular plug-in connector M8, 4-pole

Circular plug-in connector M12, 8-pole

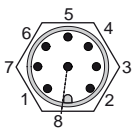

| Output signal: | Pin | Color | Configuration | External circuit |
|---|----------|--------|--|------------------|
| 2) 4 - 20 mA or 0 - 10 V (MODE = 4 - 20 / 0 - 10) | 4 (AOUT) | yellow | 4 - 20 mA or 0 - 10 V manipulated variable | |
| | 6 | pink | GND - Analog output | |

2) Available for all models except for identification number 182383

Table 8: Configuration of circular plug-in connector M12, 8-pole

MAN 1000094736 EN Version: G Status: RL (released / freigegeben) printed: 13.01.2011

8.2. Electrical installation of the control cabinet model

WARNING!

Risk of injury from incorrect installation!

Incorrect installation can damage or destroy the Type 8611 eCONTROL.

- The electrical installation may be performed by authorized electricians only!

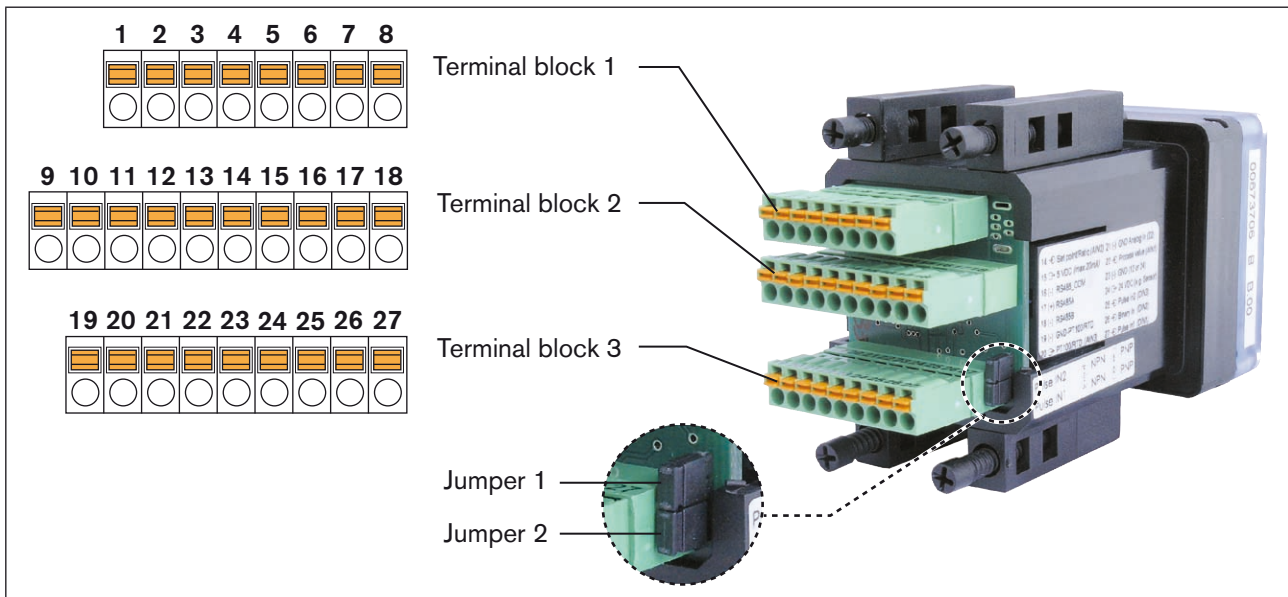
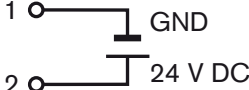



Figure 9: Control cabinet model; connection PCB with spring terminals and jumpers

8.2.1. Terminal assignment

Terminal block 1

| Terminal | Configuration | External circuit |
|------------|-------------------------------|---|
| 1 | GND – Electrical power supply |  <p>24 V DC ± 10 % max. residual ripple 10 %</p> |
| 2 | 24 V DC power supply | |
| 3 (BO2) | Binary output 2 (B_O2) |  |
| 4 (BO1) | Binary output 1 (B_O1) |  |

| Terminal | Configuration | External circuit |
|------------|---|--|
| 5 (BO3) | (+) Aeration valve (PCV) or valve 1 (2P - T or 3P - T) | <div style="display: flex; justify-content: space-around;"> <div style="text-align: center;"> <p>MODE = 2P - T or 3P - T</p> <p>NC / NO valve max. 1 A</p> </div> <div style="text-align: center;"> <p>MODE = PCV</p> <p>NC valve max. 1 A</p> </div> </div> |
| 6 | (-) Aeration valve (PCV) or valve 1 (2P - T or 3P - T) | |
| 7 (BO4) | (+) Proportional valve (SCV), bleed valve (PCV) or valve 2 (3P - T) | <div style="display: flex; justify-content: space-around;"> <div style="text-align: center;"> <p>MODE = 3P - T</p> <p>NC / NO valve max. 1 A</p> </div> <div style="text-align: center;"> <p>MODE = SCV</p> <p>NC valve max. 1.5 A</p> </div> <div style="text-align: center;"> <p>MODE = PCV</p> <p>NO valve max. 1 A</p> </div> </div> |
| 8 | (-) Proportional valve (SCV), bleed valve (PCV) or valve 2 (3P - T) | |

Table 9: Configuration of terminal block 1

Terminal block 2

| Terminal | Configuration | External circuit |
|--------------|---|--|
| 9 | GND – Analog output | 9 ○ — GND |
| 10 (AOUT) | (+) Analog output (process value or manipulated variable for valve) | 10 ○ → 4 - 20 mA / 0 - 10 V |
| 11 | GND – Sensor, actuating element | 11 ○ — GND |
| 12 | 24 V DC sensor supply or actuating element | 12 ○ → 24 V DC |
| 13 | not used | not used |
| 14 (AIN2) | (+) External set-point value / ratio 4 - 20 mA / 0 - 10 V | 14 ← ○ 4 - 20 mA / 0 - 10 V (Source) (21 ○ — A-GND) |
| 15 | (+) 5 V DC sensor supply (max. 20 mA) | 15 ○ → 5 V DC (1, 11, or 23 ○ — GND) |
| 16 | RS485_COM | 16 ○ — RS485_COM |
| 17 | RS485_A (+) | 17 ○ — RS485_A |
| 18 | RS485_B (-) | 18 ○ — RS485_B |

Table 10: Configuration of terminal block 2

MAN 1000094736 EN Version: G Status: RL (released / freigegeben) printed: 13.01.2011

Terminal block 3







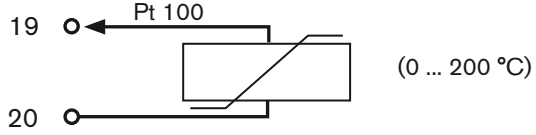

| Terminal | Configuration | External circuit |
|--|--|--|
| 19 | GND – Pt 100, RTD |  |
| 20 (AIN3) | (+) Pt 100, RTD (power supply) | |
| 21 | GND – Analog input | 21 — A-GND |
| 22 (AIN1) | (+) Process value input 4 - 20 mA / 0 - 10 V | 22 ← 4 - 20 mA / 0 - 10 V (source) 21 — A-GND |
| 23 | GND – Sensor, actuating element | 23 — GND |
| 24 | 24 V DC sensor supply or actuating element | 24 → 24 V DC - Out (max. 1 A) 23 — GND |
| 25 Supply of Type 8611 (DIN3) | Frequency input 2 (NPN or PNP) Q ₂ for ratio control (MODE = RATI) | <p>Jumper 2</p> <p>  NPN  PNP </p>  |
| 25 External supply (DIN3) | Frequency input 2 (NPN or PNP) Q ₂ for ratio control (MODE = RATI) | <p>Jumper 2</p> <p>  NPN  PNP </p>  |
| 26 (DIN2) | (+) Binary input | <p>26 — 0 ... 2.7 V (log. 0) max. 1 kHz</p> <p>26 — 3 ... 30 V (log. 1)</p> <p>1, 11, or 23 — GND</p> |
| 27 Supply of Type 8611 (DIN1) | Frequency input 1 (NPN or PNP) Actual value flow-rate / Q ₁ for ratio control (MODE = RATI) | <p>Jumper 1</p> <p>  NPN  PNP </p>  |
| 27 External supply (DIN1) | Frequency input 1 (NPN or PNP) Actual value flow-rate / Q ₁ for ratio control (MODE = RATI) | <p>Jumper 1</p> <p>  NPN  PNP </p>  |

Table 11: Configuration of terminal block 3

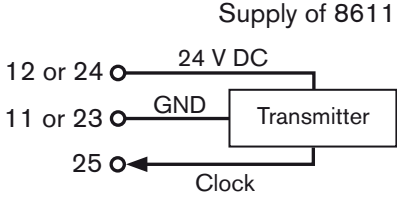
MAN 1000094736 EN Version: G Status: RL (released / freigegeben) printed: 13.01.2011

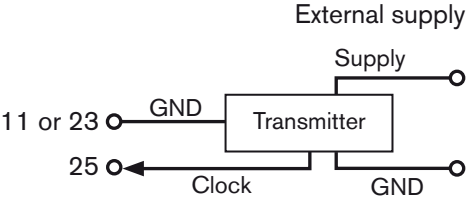
9. OPERATION AND FUNCTION

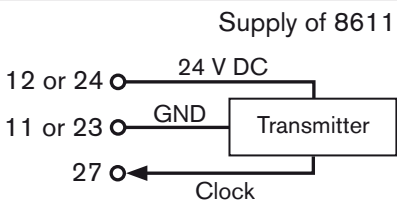
9.1. Control and display elements

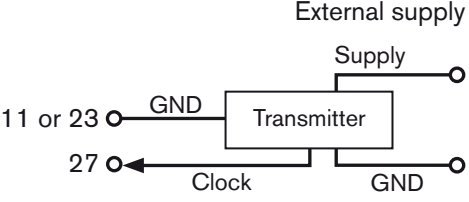
The control and display element of the eCONTROL Type 8611 is equipped with 3 buttons and an LCD-Matrix display.

9.1.1. Display elements

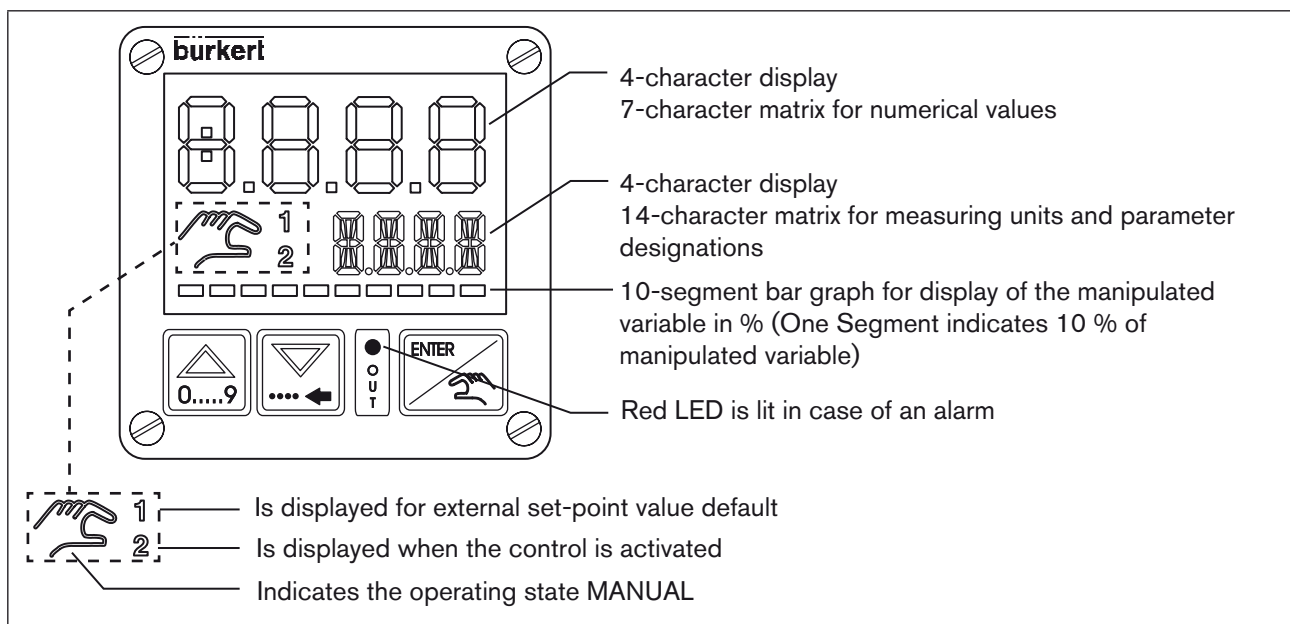

Figure 10: Display elements

9.1.2. Control elements

Arrow keys



left



right

- Change the display at the process operating level in AUTOMATIC operating state
- Change the menu options in MANUAL operating state and at the configuration level
- Entering of numerical values

ENTER button



- Switches between the operating states AUTOMATIC and MANUAL
- Switches between operating and configuration level
- Selection of menu option
- Take over settings

The detailed description of the function can be found in chapter 9.3. *Function of the keys.*

9.2. Operating levels and operating states

2 operating levels and 2 operating states AUTOMATIC and MANUAL are available for the operation and setting of the eCONTROL Type 8611.

Level 1: Process operating level

At level 1, the user can switch between 2 operating states AUTOMATIC and MANUAL.

Operating state: AUTOMATIC: The normal control mode is executed and monitored.

MANUAL: Quick access to important functions and test functions.

The operating state MANUAL is indicated on the display by a hand symbol.

Level 2: Configuration level

At level 2, the user can change the basic settings of the controller.

After switching on the operating voltage, the controller is at the process operating level and in the AUTOMATIC operating state.

When the operating voltage is applied, the software version will light up on the display for approx. 2 seconds. If the ENTER key is pressed during these 2 seconds, the sub-version is displayed. After this, the controller is once again at the process operating level.

9.2.1. Switching between the operating levels and operating states

The ENTER key is pressed to change the operating level and operating state (see *Figure 11:*).



Any changes made within the configuration level are only stored after returning to the process operating level.

Changes in the MANUAL operating state can be made while the controller is running.

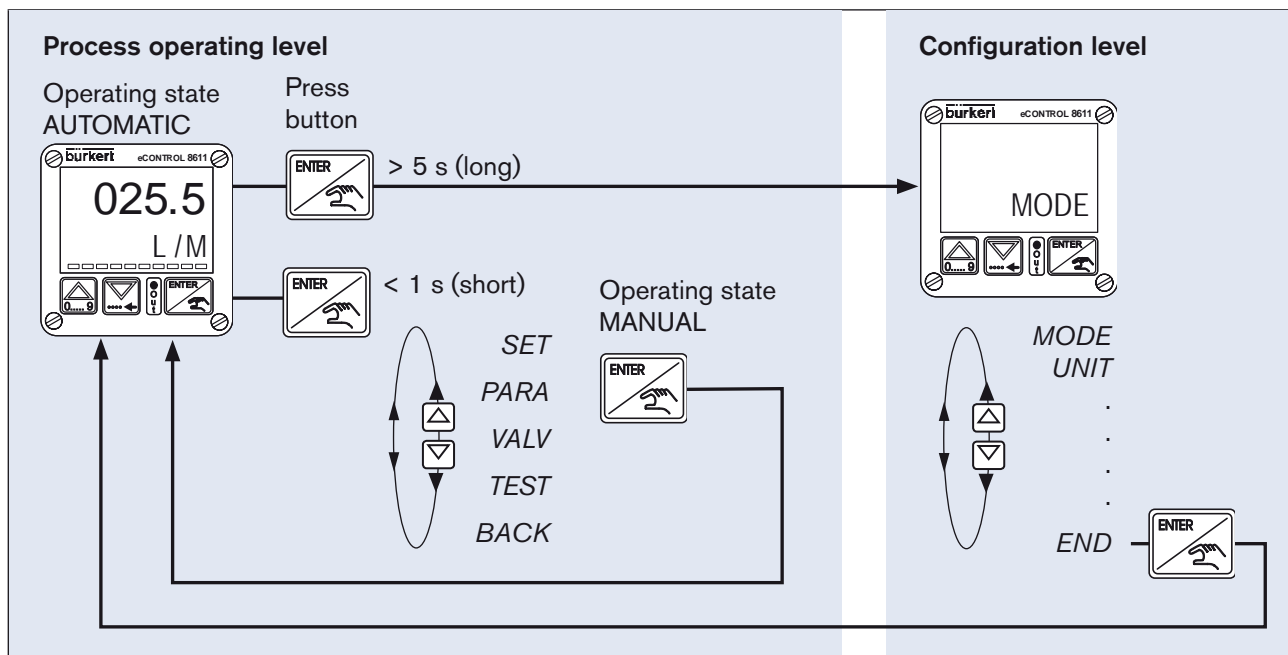

Figure 11: Changing the operating level and operating state

9.3. Function of the keys

The device is operated using two arrow keys and one ENTER key.

The function of these in respect of the operating level and the operating state is shown in *Table 12*: below.



| Operating level | Operating state |  |  |  |
|--|--------------------------------------|---|---|--|
| Level 1: Process operating level | AUTOMATIC | Switch display between actual value, set-point value and manipulated variable | | <ul style="list-style-type: none"> Press key briefly (< 1 s): Switches to operating state MANUAL Press and hold key (> 5 s): Switches to configuration level |
| | MANUAL | Switches to the last menu option | Switches to the next menu option | <ul style="list-style-type: none"> Selection of menu option Take over settings Switches to operating state AUTOMATIC (for display <i>BACK</i>) |
| Entering of values Increase value | | Change by one position to the left | | |
| Level 2: Configuration level | Switches to the last menu option | Switches to the next menu option | <ul style="list-style-type: none"> Selection of menu option Take over settings Switches to process operating level and to operating state AUTOMATIC (for display <i>END</i>) | |
| | Entering of values Increase value | Change by one position to the left | | |

Table 12: Function of the keys

10. OPERATING STRUCTURE

10.1. Operating structure of the process operating level in MANUAL operating state

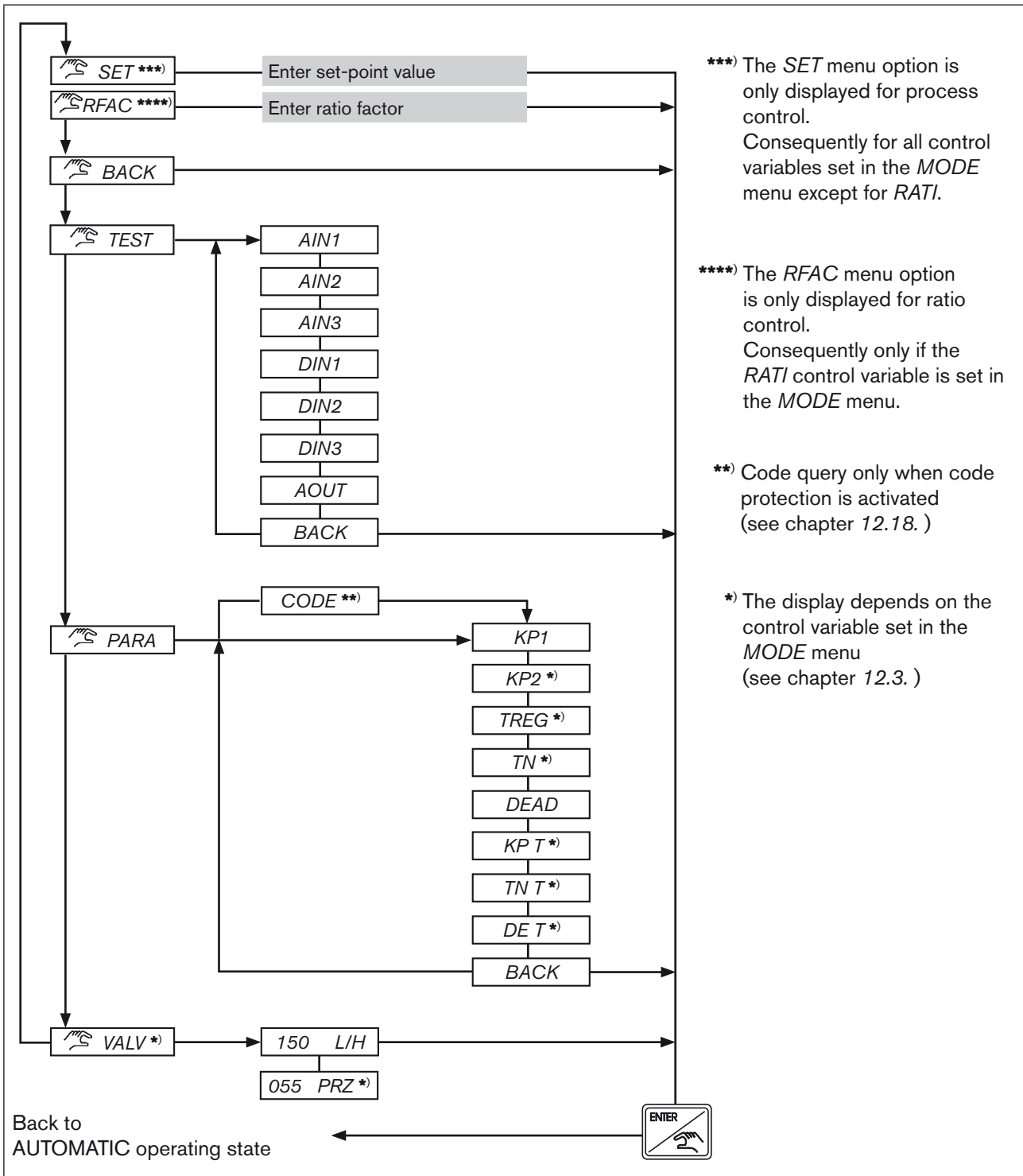

MAN 1000094736 EN Version: G Status: RL (released / freigegeben) printed: 13.01.2011

30 Figure 12: Operating structure of the process operating level in MANUAL operating state

10.2. Operating structure of the configuration level

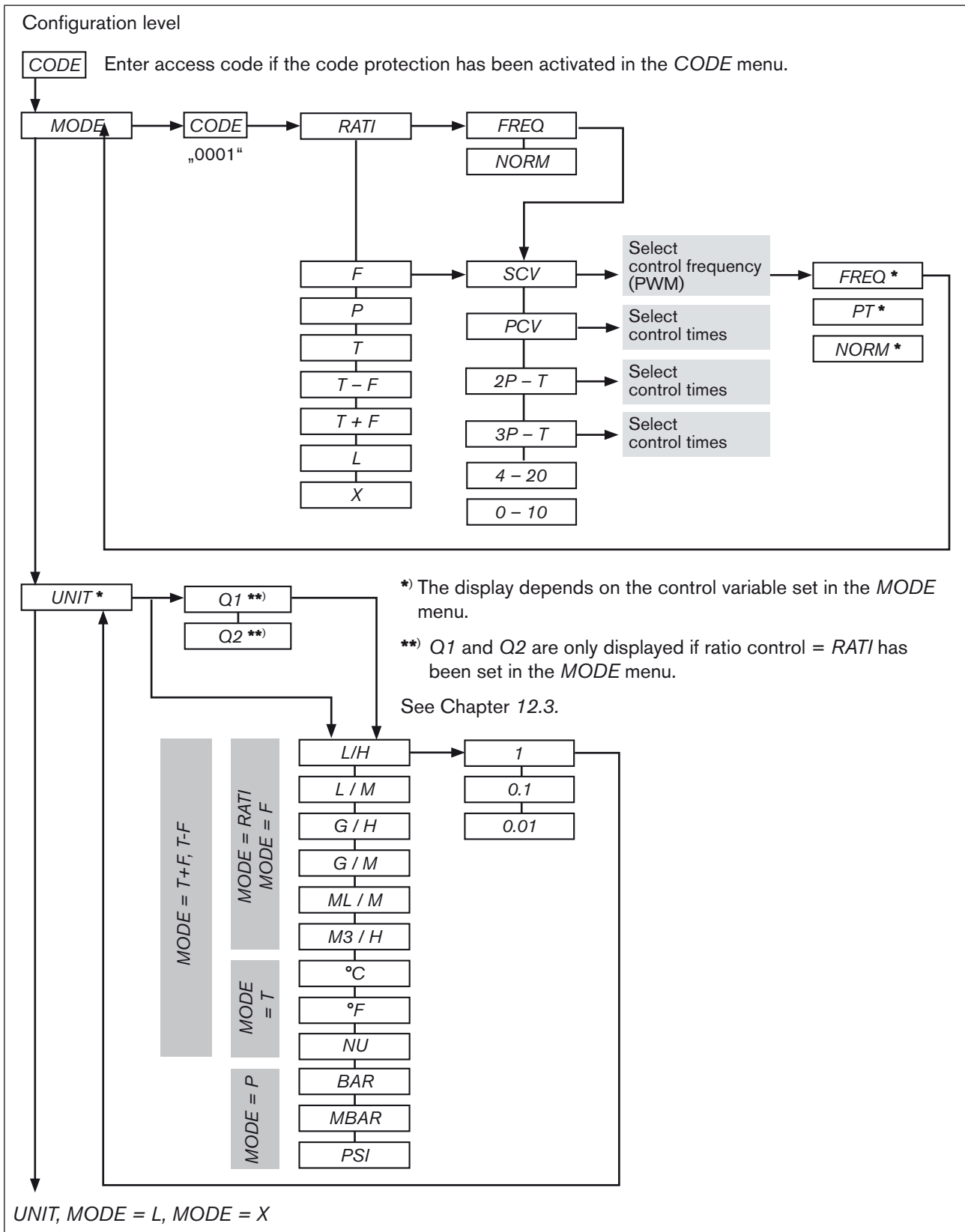

MAN 1000094736 EN Version: G Status: RL (released / freigegeben) printed: 13.01.2011

Figure 13: Operating structure of the configuration level - 1 of 6

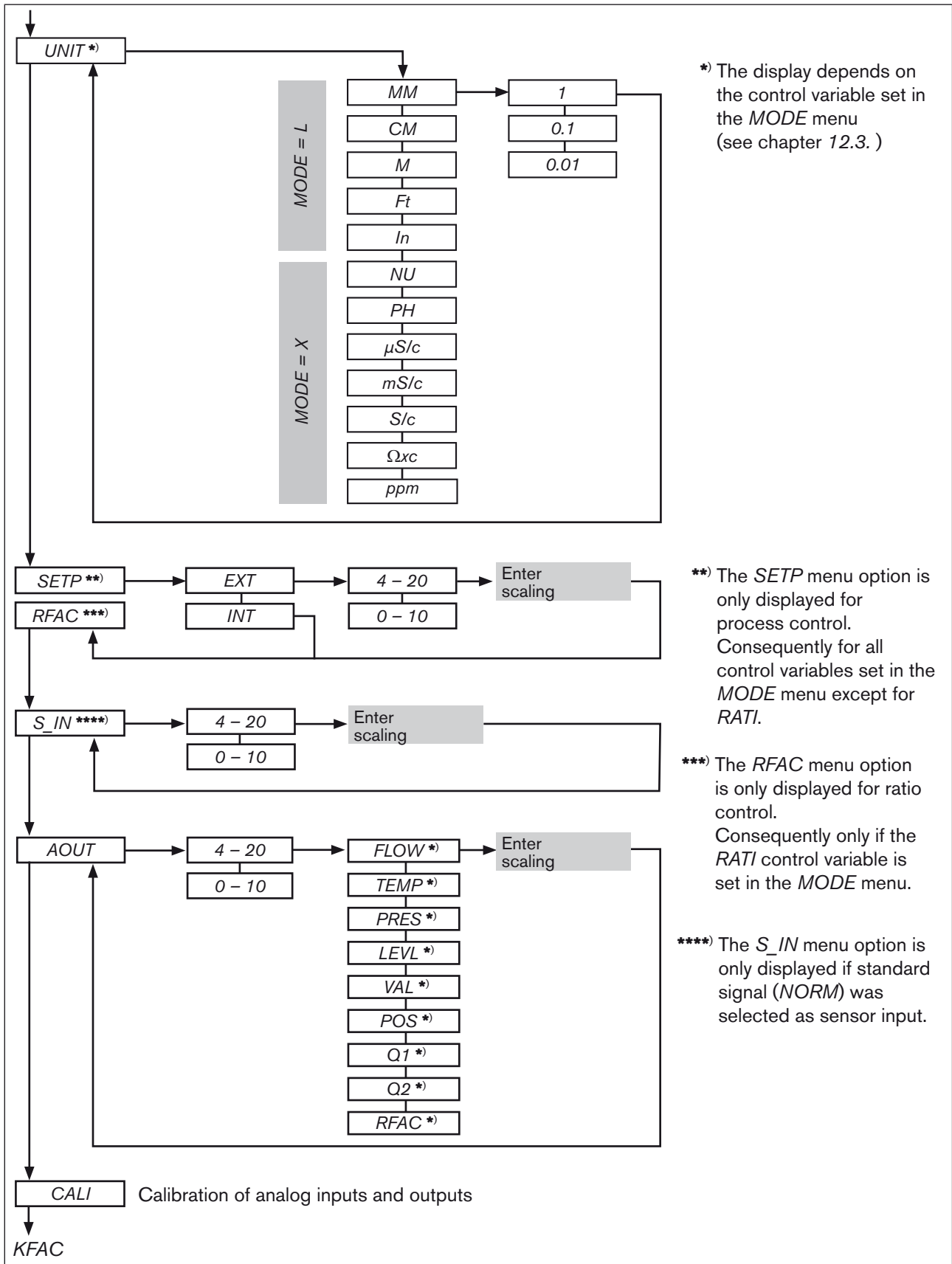

MAN 1000094736 EN Version: G Status: RL (released | freigegeben) printed: 13.01.2011

32 Figure 14: Operating structure of the configuration level - 2 of 6

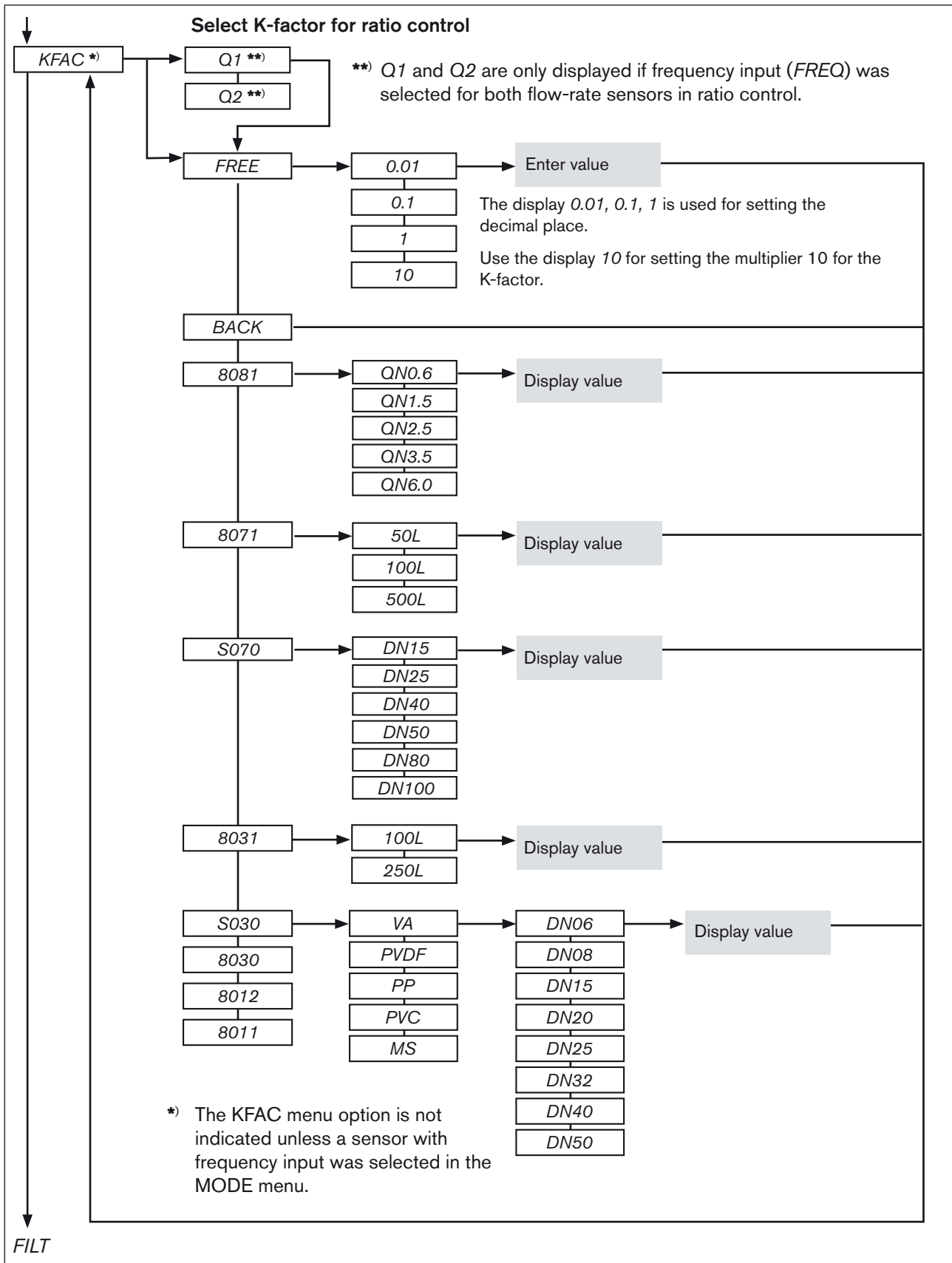

MAN 1000094736 EN Version: G Status: RL (released / freigegeben) printed: 13.01.2011

Figure 15: Operating structure of the configuration level - 3 of 6

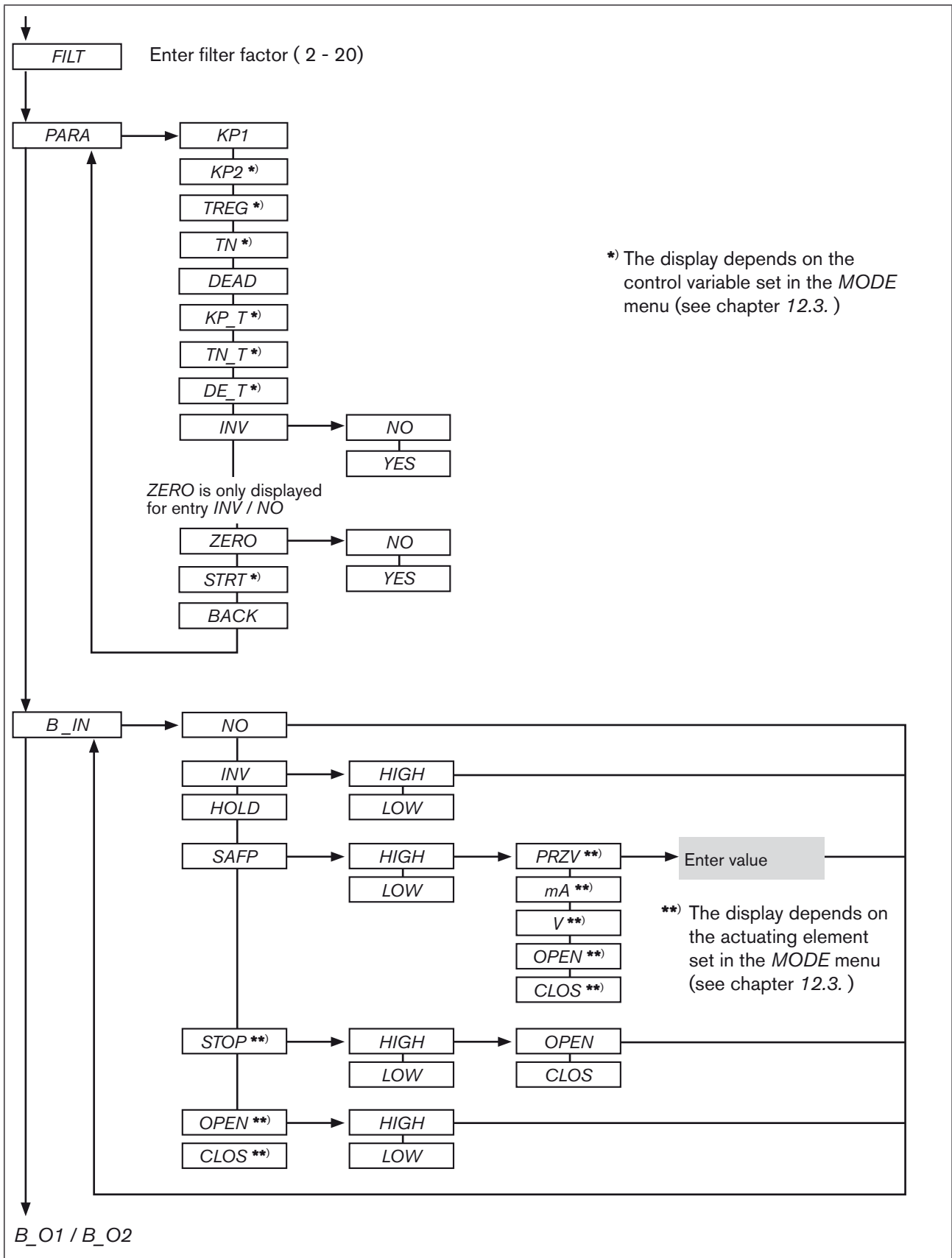

MAN 1000094736 EN Version: G Status: RL (released / freigegeben) printed: 13.01.2011

Figure 16: Operating structure of the configuration level - 4 of 6

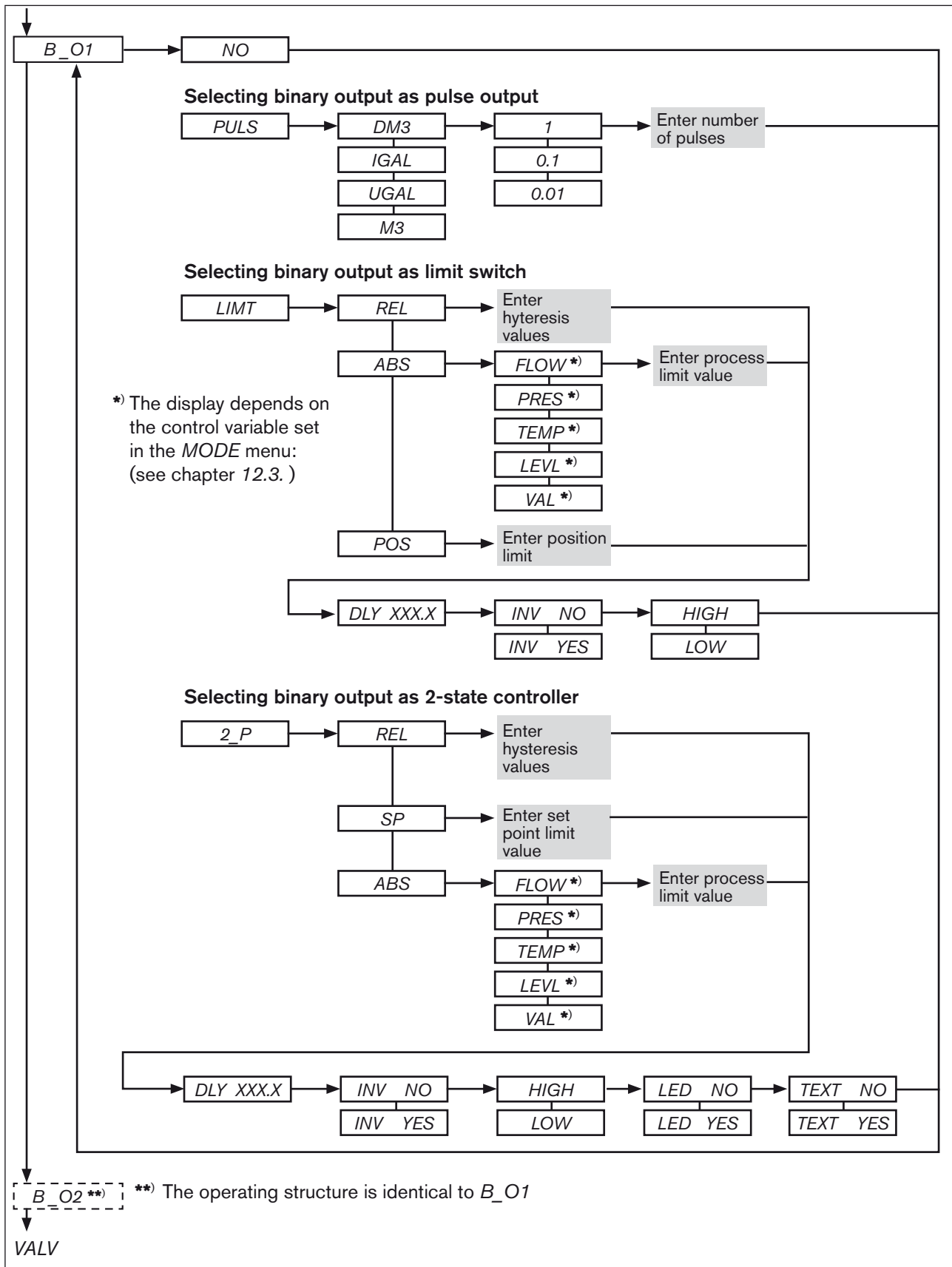

MAN 1000094736 EN Version: G Status: RL (released / freigegeben) printed: 13.01.2011

Figure 17: Operating structure of the configuration level - 5 of 6

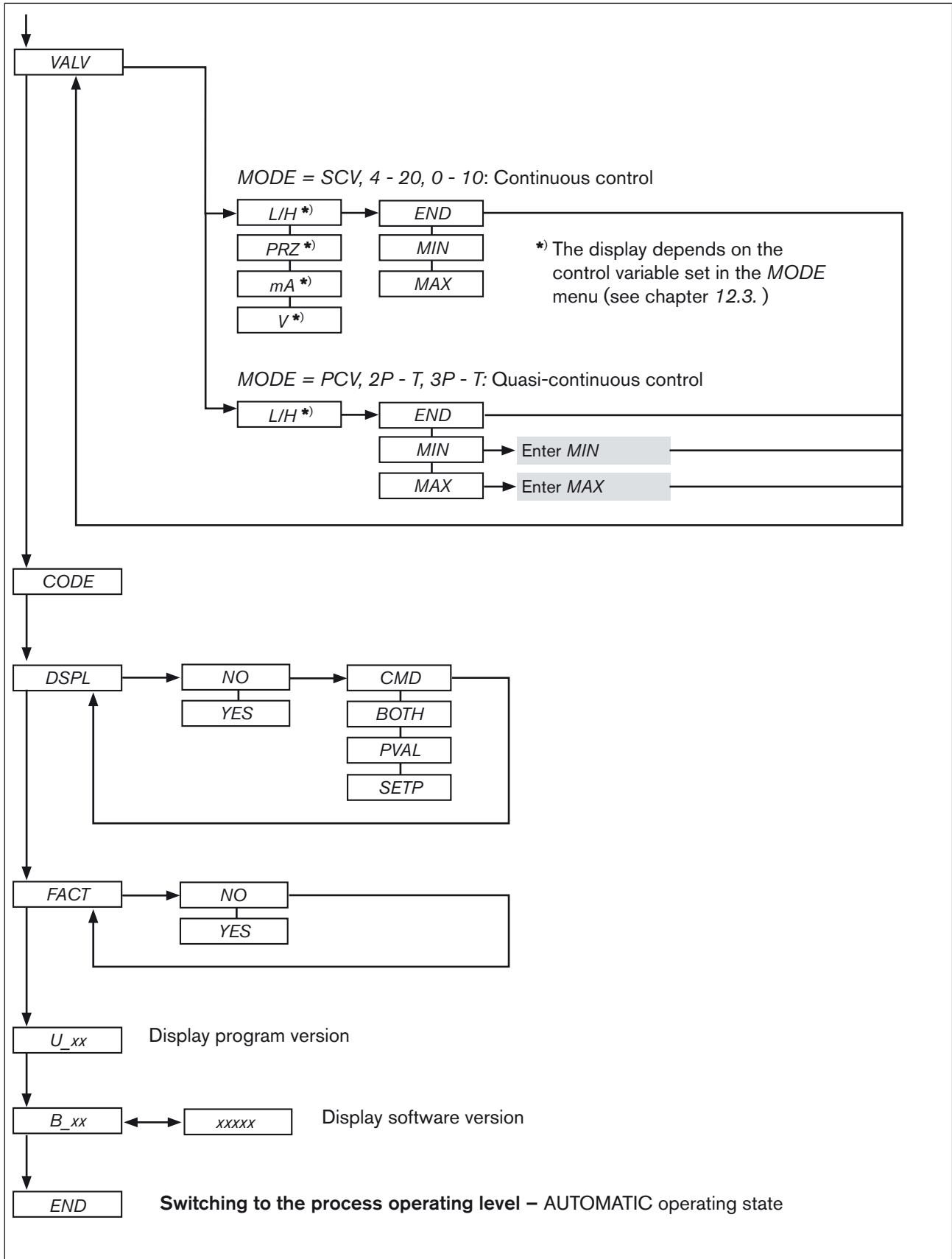

MAN 1000094736 EN Version: G Status: RL (released / freigegeben) printed: 13.01.2011

Figure 18: Operating structure of the configuration level - 6 of 6

11. FUNCTIONS OF THE PROCESS OPERATING LEVEL

11.1. Operating state AUTOMATIC

After switching on the operating voltage, the controller is at the process operating level and in the AUTOMATIC operating state. The normal control mode is executed and monitored.

11.1.1. Displays in the AUTOMATIC operating state

Press the arrow keys to switch between 4 different displays for monitoring the control operation. Which of these displays should be shown as start display after applying the operating voltage can be defined in the *DSPL* menu (see 12.19. *DSPL* - Setting the display).

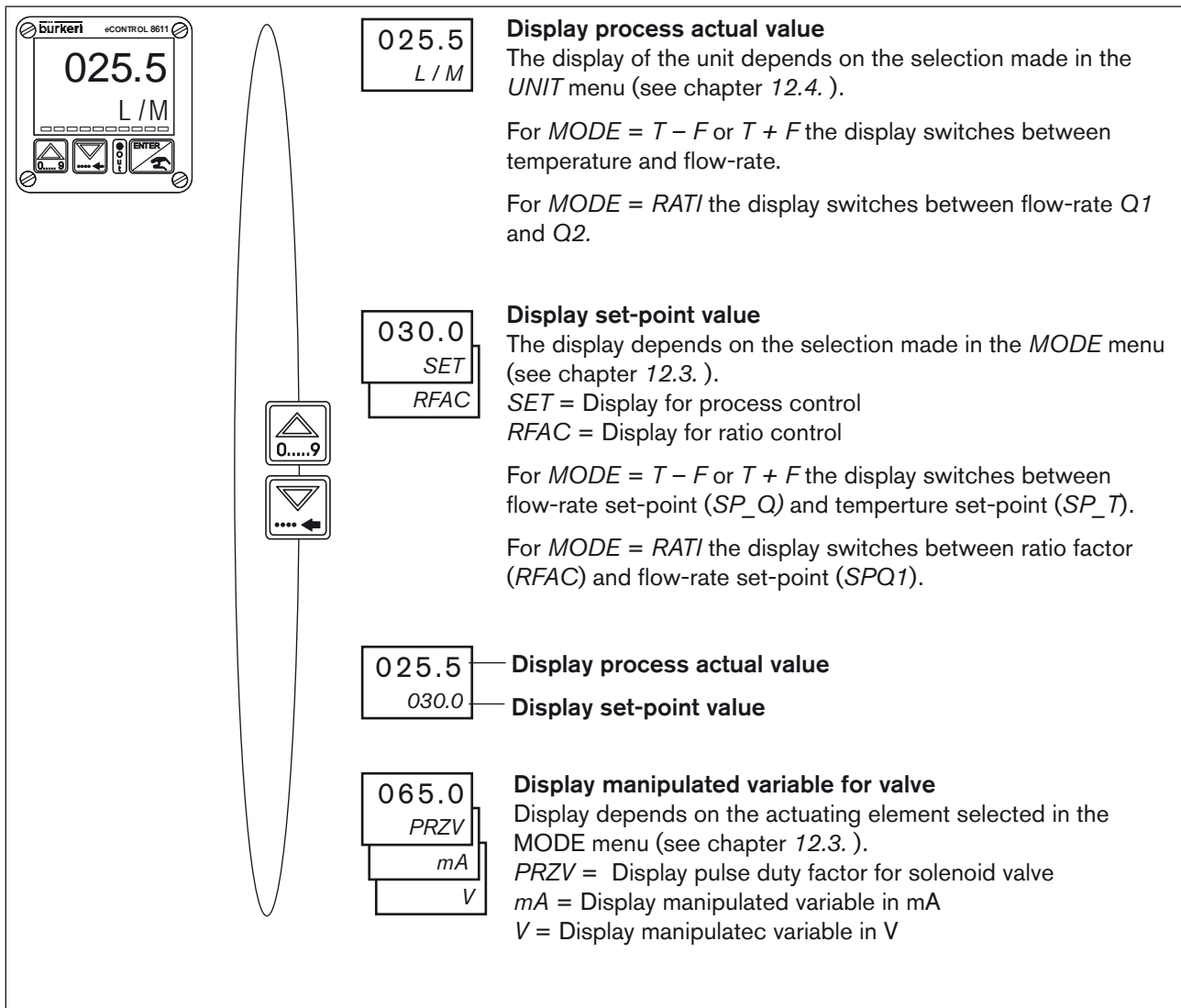

Figure 19: Displays in the AUTOMATIC operating state

MAN 1000094736 EN Version: G Status: RL (released | freigegeben) printed: 13.01.2011

11.2. Operating state MANUAL

Briefly press (< 1 s) the ENTER key to go to the MANUAL operating state. The operating state is indicated on the display by a hand symbol.

11.3. Specific menu options of process and ratio control

The display of some menu options differs for the process and the ratio control. This is described in detail in the respective menu descriptions.

The control type is specified by the control variable selected in the *MODE* menu:

- Process control: is active if all control variables have been selected in the *MODE* menu except for *RATI*.
- Ratio control is active if the *RATI* control variable has been selected in the *MODE* menu (see chapter 12.3.1. *RATI - Selection of external sensors for ratio control*).

11.4. Menu options in the MANUAL operating state

| | |
|-------------|--|
| SET | <p>Set-point value default for process control See chapter 11.5. <i>SET - Set-point value default for process control</i></p> <ul style="list-style-type: none"> ▪ Menu option is displayed for process control. ▪ Is not available if external set-point value default is selected. |
| RFAC | <p>Ratio factor default for ratio control See chapter 11.6. <i>RFAC - Ratio factor default for ratio control</i></p> <ul style="list-style-type: none"> ▪ Menu option is only displayed for ratio control (<i>MODE = RATI</i>). ▪ Is not available if external set-point value default is selected. |
| BACK | <p>When <i>BACK</i> is displayed on the display, press the ENTER key briefly to switch to <i>AUTO-MATIC</i> operating state. When an arrow key is pressed, the next or respectively the previous menu option is displayed.</p> |
| TEST | <p>Display of the analog inputs and outputs and the digital inputs. See chapter 11.7.</p> |
| PARA | <p>Adjusting the controller parameters (Code must be entered if code protection is activated). See chapter 11.8. <i>PARA - Display and optimization of the controller parameters</i></p> |
| VALV | <p>Manual opening and closing of the connected valves. See chapter 11.9.</p> |

Table 13: Menu options of the process operating level

11.5. SET - Set-point value default for process control

In the case of process control, the set-point value default can be entered in the MANUAL operating state using the *SET* menu.

Process control is active if all control variables have been set in the *MODE* menu except for *RATI*.

Setting the set-point value default in the menu:

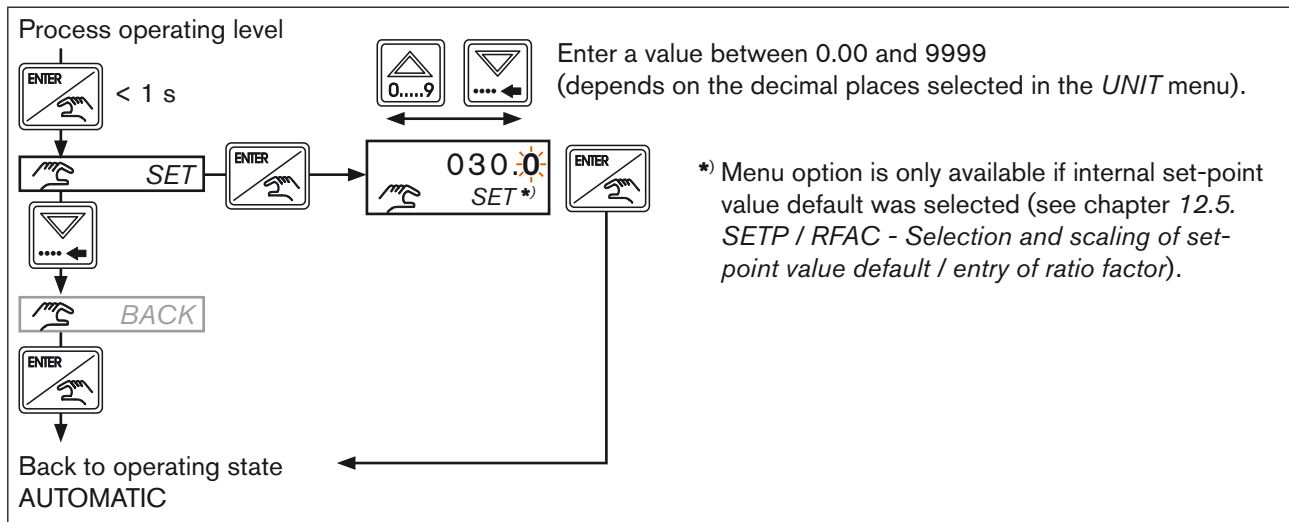

Figure 20: SET; Set-point value default for process control

11.6. RFAC - Ratio factor default for ratio control

In the case of ratio control, the ratio factor can be entered in the MANUAL operating state using the *RFAC* menu. The ratio control is active if the *RATI* control was set in the *MODE* menu.

Setting the ratio factor in the menu:

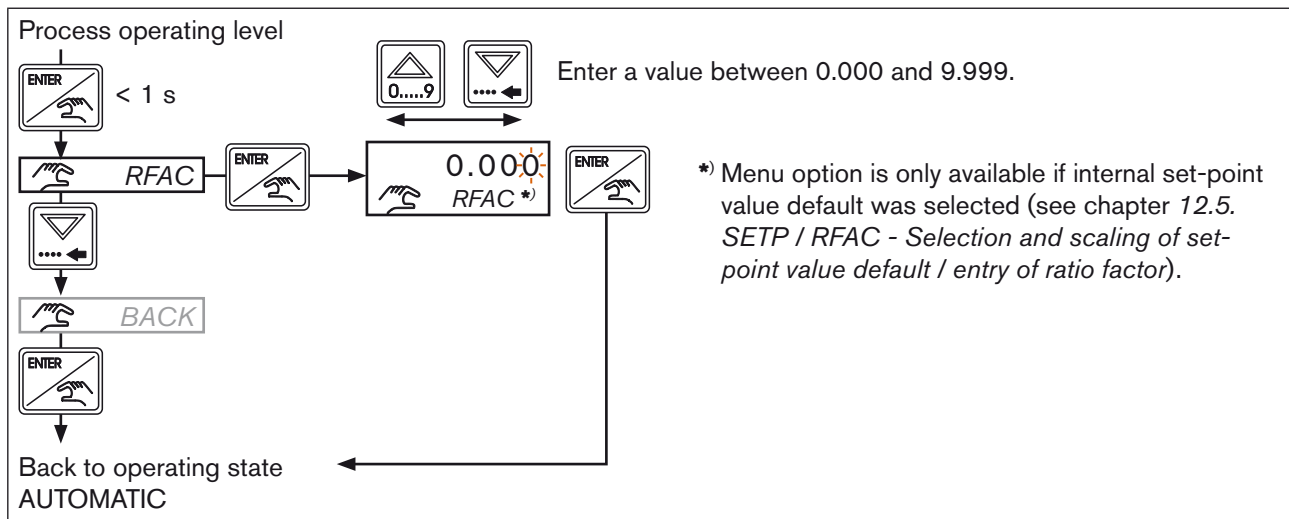

Figure 21: RFAC; Ratio factor default for ratio control

11.7. TEST – Display of the analog inputs and outputs and the digital inputs



The analog inputs and outputs and the digital inputs are displayed while the controller is operating. No changes can be made.

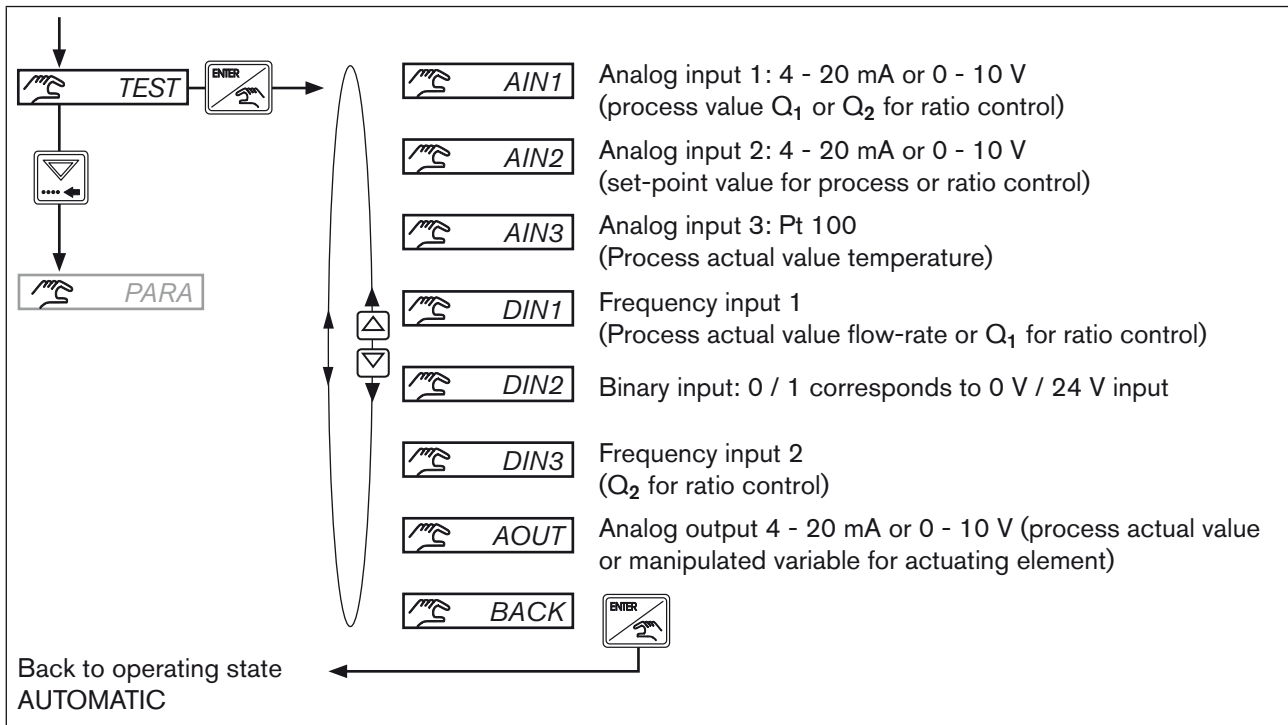

Figure 22: TEST; Display of the analog inputs and outputs and the digital inputs

11.8. PARA – Display and optimization of the controller parameters

In this menu of the process operating level, the controller parameters of the running process can be optimized. The new controller parameters are taken over immediately after pressing the ENTER key. The detailed description of the controller parameters depending on the selected process variable can be found in chapter 11.8. *PARA – Display and optimization of the controller parameters.*

! Access to this menu can be protected by a user code (see chapter 12.18. *CODE - Code protection*)

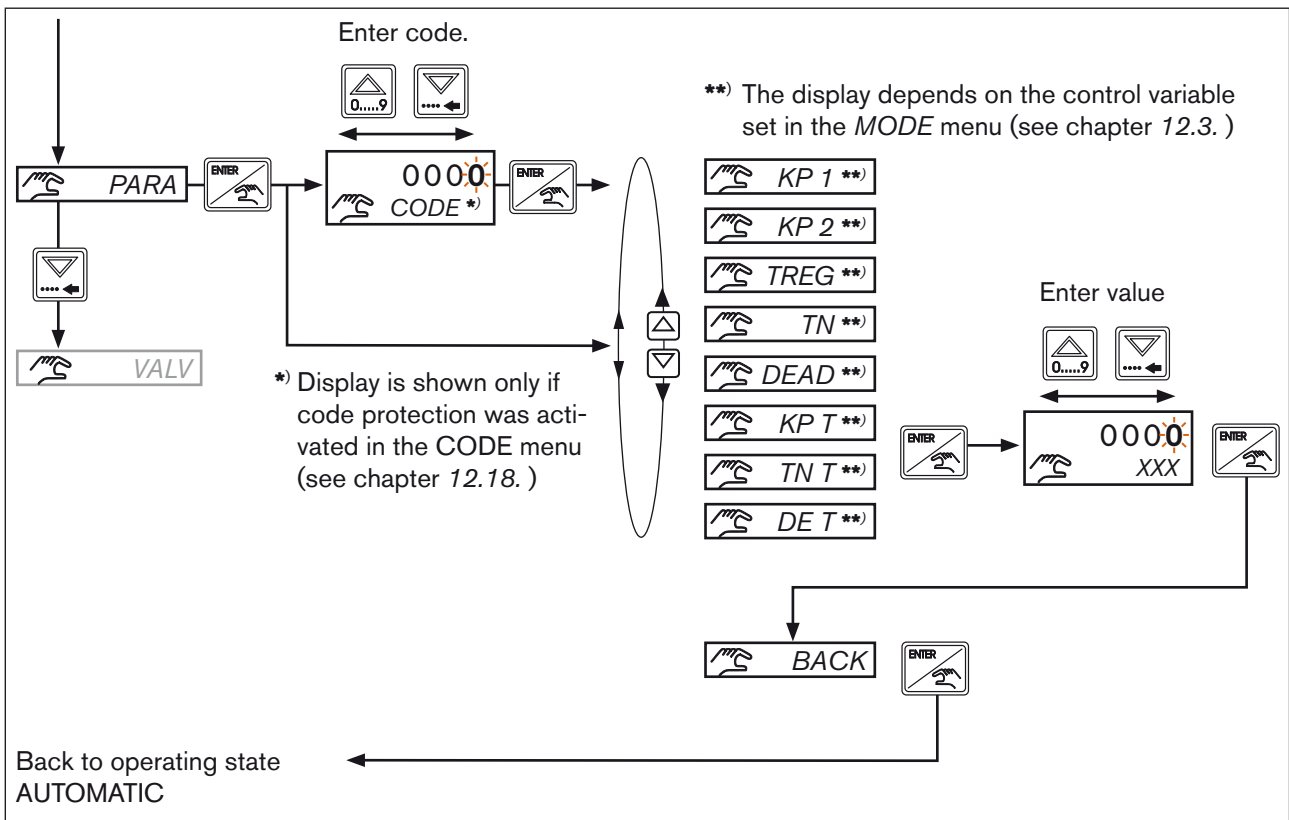

Figure 23: PARA; Display and optimization of the controller parameters

MAN 1000094736 EN Version: G Status: RL (released | freigegeben) printed: 13.01.2011

11.9. VALV – Manual opening and closing of the connected actuating elements

! If the *VALV* menu option is selected, the controller is stopped and the actuating element remains in the last position. The manipulated variable can now be increased or lowered relatively to the last position by pressing the key.

The display in the *VALV* menu option depends on the control variable set in the *MODE* menu:

- *MODE* = *SCV*, 0 - 10, 4 - 20, 2*P* - *T*, 3*P* - *T* (Reset time T_N activated, $T_N > 0$)
- *MODE* = *PCV*, 2*P* - *T*, 3*P* - *T* (Reset time T_N deactivated, $T_N = 9999$)

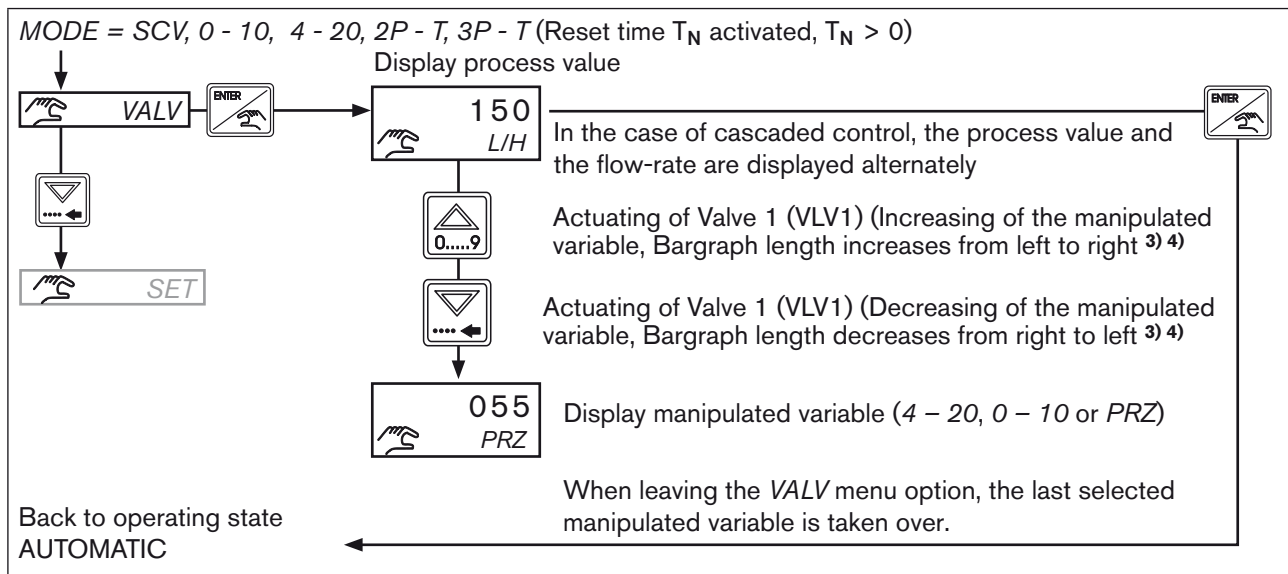

Figure 24: VALV; Manual opening and closing of the actuating element

3) Changing the manipulated variable

Each time the key is pressed: *MODE* = *SCV*, 2*P* - *T*, 3*P* - *T* by 1%
MODE = 4 - 20 by 0.2 mA
MODE = 0 - 10 by 0.1 V

Continuous pressing of the key > 80 ms: Quick adjustment of the manipulated variable

4) The manipulated variable can be changed between 0 and 100 %.

Only for *MODE* = 3*p* - *T* the manipulated variable can be changed between -100 % and +100 %.

-100 % = Valve 2 is controlled by 100 % pulse duty factor
+100 % = Valve 1 is controlled by 100 % pulse duty factor

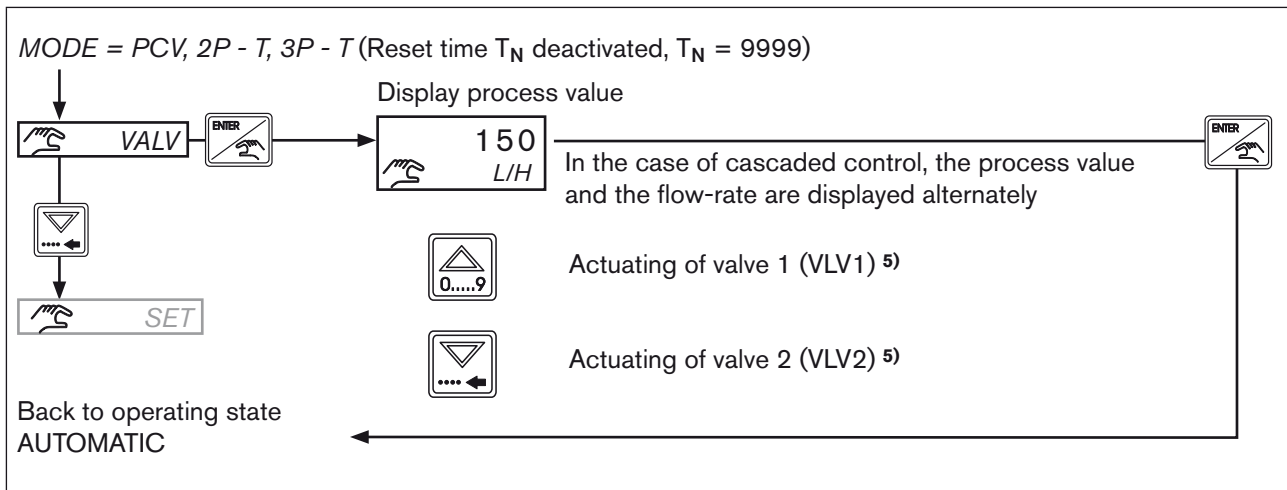

Figure 25: VALV; Manual opening and closing of the actuating element

4) Key functions

- Each time the key is pressed: the actuating element is operated for 40 ms
- Continuous pressing of the key > 80 ms: Continuous control of the actuating element



The detailed description of the VALV function can be found in chapter 12.17. VALV - Test function and setting of the control range

12. FUNCTIONS OF THE CONFIGURATION LEVEL

12.1. General Description

In the following description of the menu options and their operating structures, the entire software of the eCONTROL Type 8611 is explained. This complete software scope is only available for the control cabinet model of the eCONTROL Type 8611.

The menu structure may vary depending on the device model (wall, valve, rail or fitting assembly). In accordance with the device model, only menu options that are logically purposeful for the application area can be selected. This pre-selection is made upon delivery of the controller in accordance with the chosen order part number.



Any changes made within the configuration level are only stored after returning to the process operating level.



Access to the configuration level can be protected by a code. Any unauthorized persons are thus denied access and cannot change the parameters.

If the code protection is activated, a code must be entered before switching to the configuration level (see chapter 12.18. *CODE - Code protection*).

12.2. Menu options of the configuration level

| | |
|-------------|---|
| MODE | Selection of control variable, actuating element and process value input. See Chapter 12.3. |
| UNIT | Selection of measuring units and decimal places. See chapter 12.4. |
| SETP | Selection and scaling of set-point value default. See chapter 12.5. |
| RFAC | Entry of ratio factor for ratio control (MODE = RATI). See chapter 12.5. |
| S_IN | Scaling of sensor input signal (4 - 20 mA or 0 - 10 V). See chapter 12.6. |
| AOUT | Scaling of analog output (4 - 20 mA or 0 - 10 V). See chapter 12.7. |
| CALI | Calibration of the analog inputs and outputs. See chapter 12.8. |
| KFAC | Entry of K-factor for flow-rate measurement. See chapter 12.11. |
| FILT | Setting of the filtering factor. See chapter 12.12. |
| PARA | Setting of the controller parameters. See chapter 12.13. |
| B_IN | Configuration of the binary input. See chapter 12.14. |
| B_O1 | Configuration of binary output 1. See chapter 12.15. |
| B_O2 | Configuration of binary output 2. See chapter 12.16. |
| VALV | Test function and setting of the control range. See chapter 12.17. |
| CODE | Code protection. See chapter 12.18. |
| DSPL | Setting of the display. See chapter 12.19. |
| FACT | Resetting to factory settings. See chapter 12.20. |
| U_XX | Display of program version. See chapter 12.21. |
| A_XX | Display of software version. See chapter 12.21. |
| END | Leaving the configuration level See Chapter 12.22. |

Table 14: Menu options of the configuration level

12.3. *MODE* - Selection of control variable, actuating element and process value input

The most important basic settings of the controller are made in this menu option.

The setting is done in 3 successive steps.

- Selection of control variable (e.g. flow-rate control, pressure control, etc.)
- Selection of actuating element (e.g. proportional valve, process valve, etc.)
- Selection of process value input (e.g. 4 - 20 mA, frequency, etc.)

! The *MODE* menu option is at the configuration level. To go there, press and hold the ENTER key (> 5 s) (see chapter 9.2. *Operating levels and operating states*).

How the settings are made in the menu is explained below.

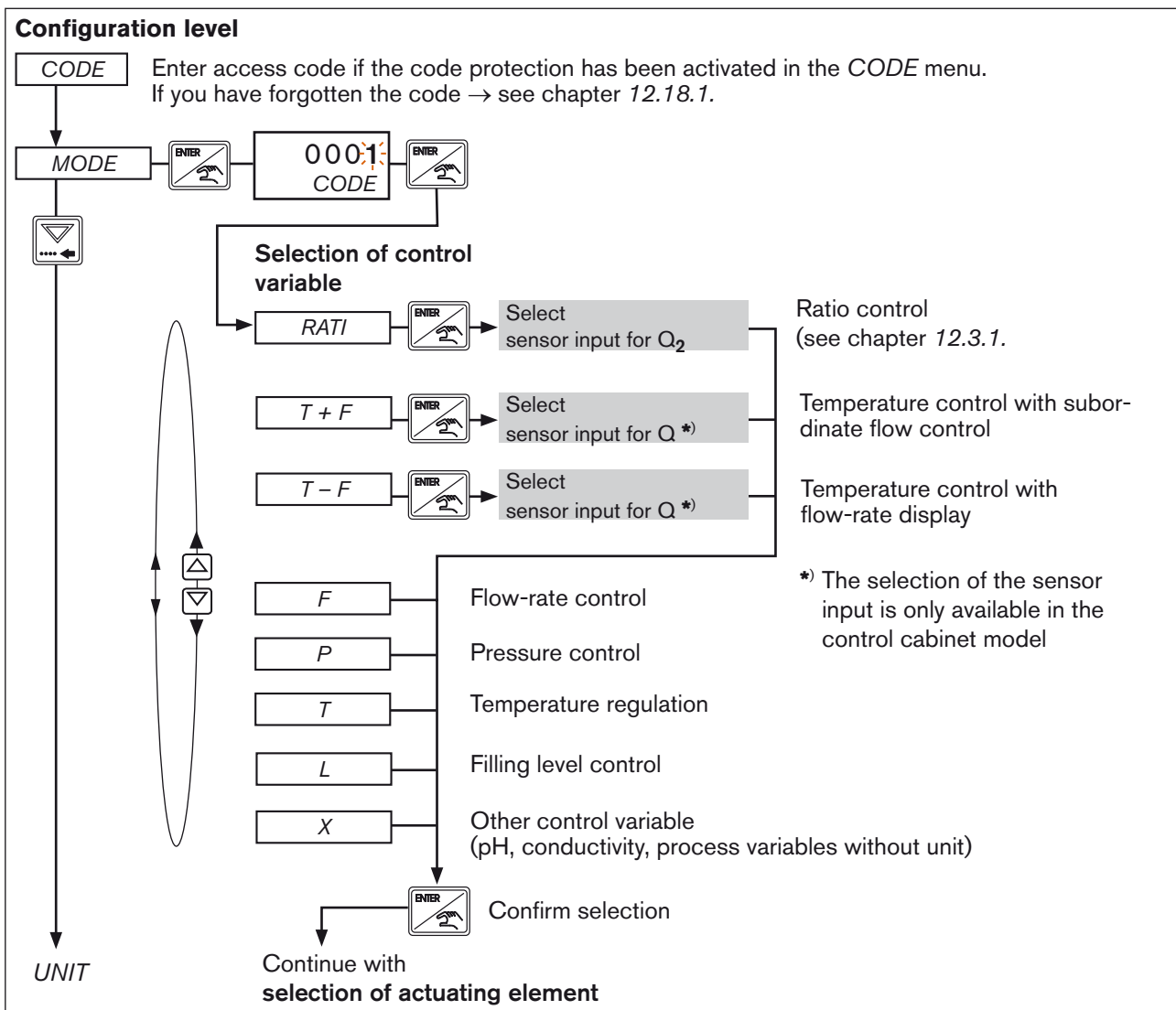

Figure 26: *MODE*; Selection of the control variable

MAN 1000094736 EN Version: G Status: RL (released / freigegeben) printed: 13.01.2011

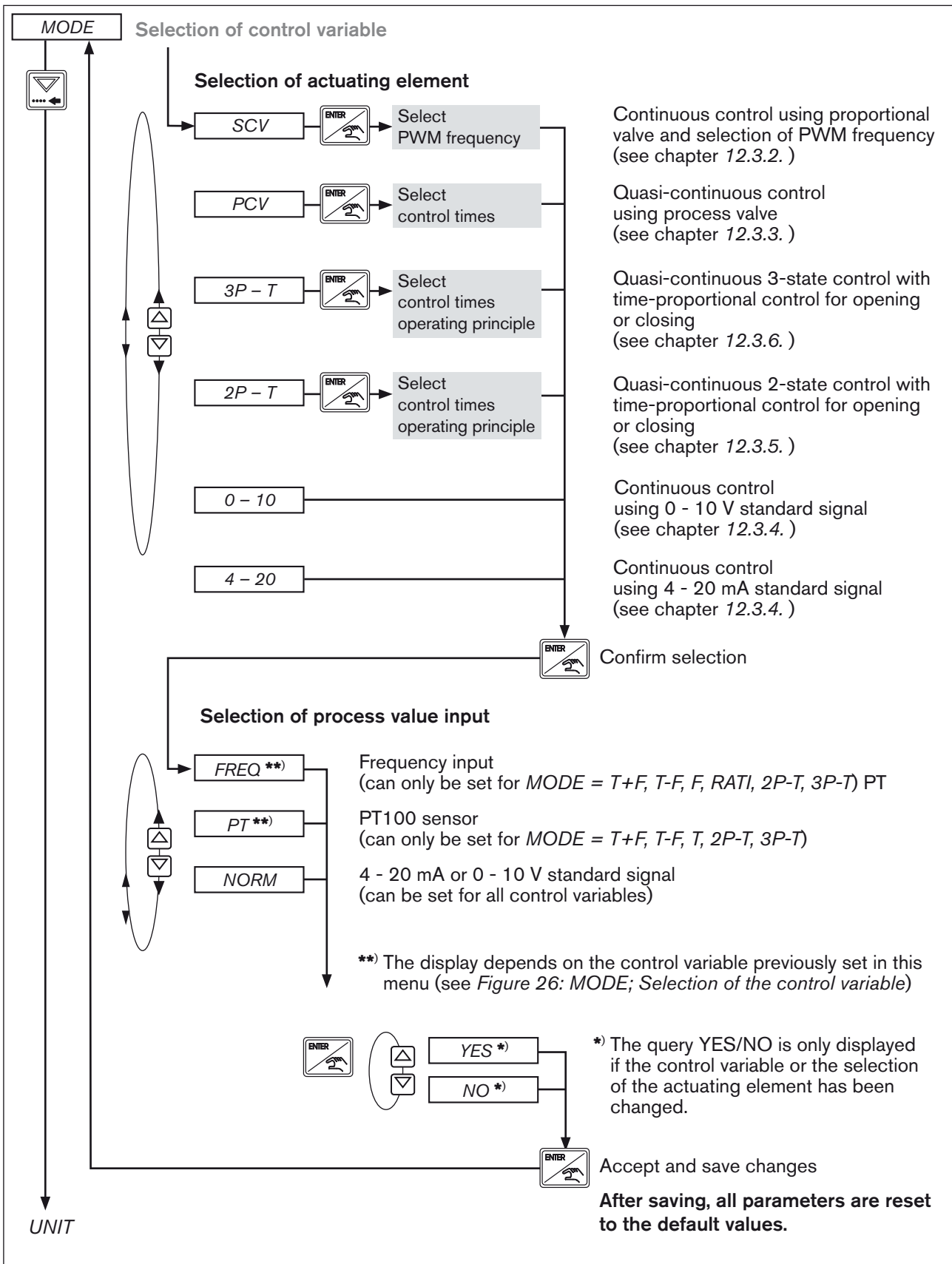

Figure 27: *MODE; Selection of the actuating element and of the process value input*

12.3.1. *RATI* - Selection of external sensors for ratio control

A ratio control can easily be implemented by combining the compact controller Type 8611 with flow-rate fitting S030 and a second flow-rate sensor.

In a ratio control, the controlled flow-rate Q_1 is adapted to the uncontrolled flow-rate Q_2 so that it corresponds to a specified mixture ratio.

The flow-rate is measured for Q_1 using the Bürkert flow-rate fitting of Type S030
for Q_2 using a second external flow-rate sensor.

The following relation exists between Q_1 and Q_2 :

$$Q_1 = \text{RFAC} \cdot Q_2$$

Q_1 : controlled flow-rate

Q_2 : uncontrolled flow-rate

RFAC: ratio factor

(for selection see chapter 11.6. *RFAC* - Ratio factor default for ratio control)

Example of a ratio control:

| | |
|-----------------------------|---|
| Selected ratio factor RFAC: | 4,00 |
| Flow-rate Q_2 : | 20 l/h |
| Control of Q_1 to: | $20 \text{ l/h} \cdot 4 = 80 \text{ l/h}$ |

Schematic representation:

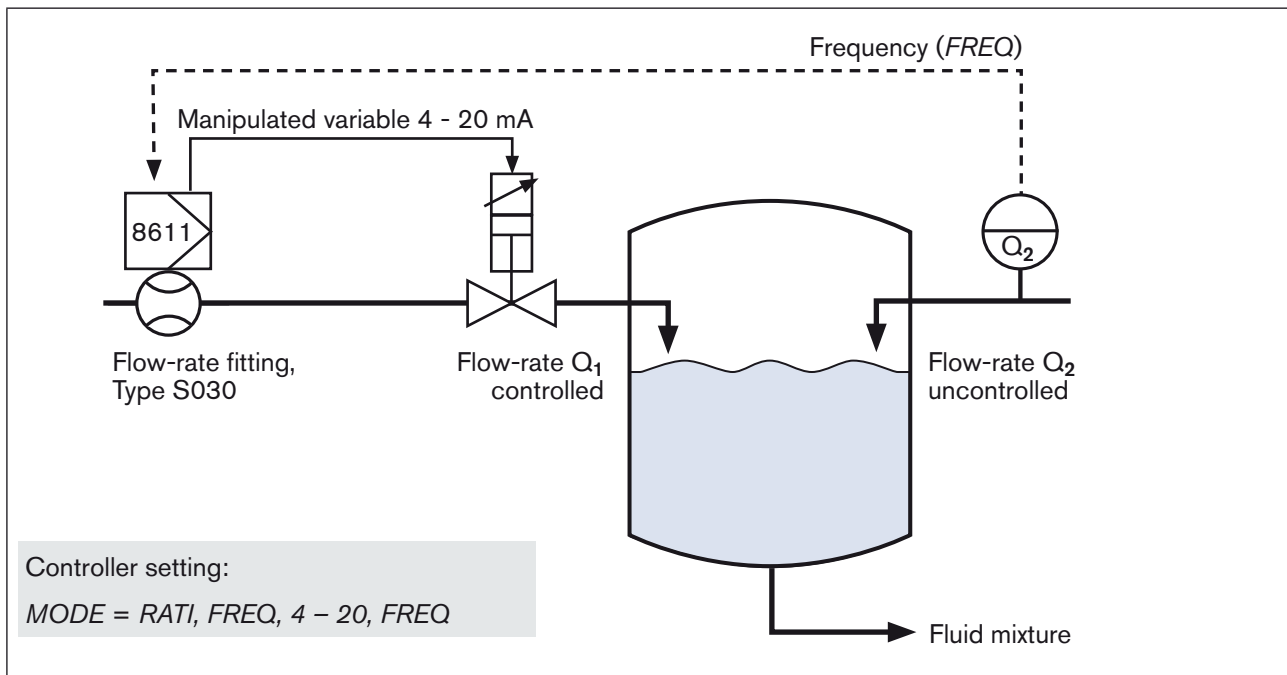

Figure 28: Ratio control using process controller Type 8611 (assembly directly on flow-rate fitting Type S030).

Settings in the menu:

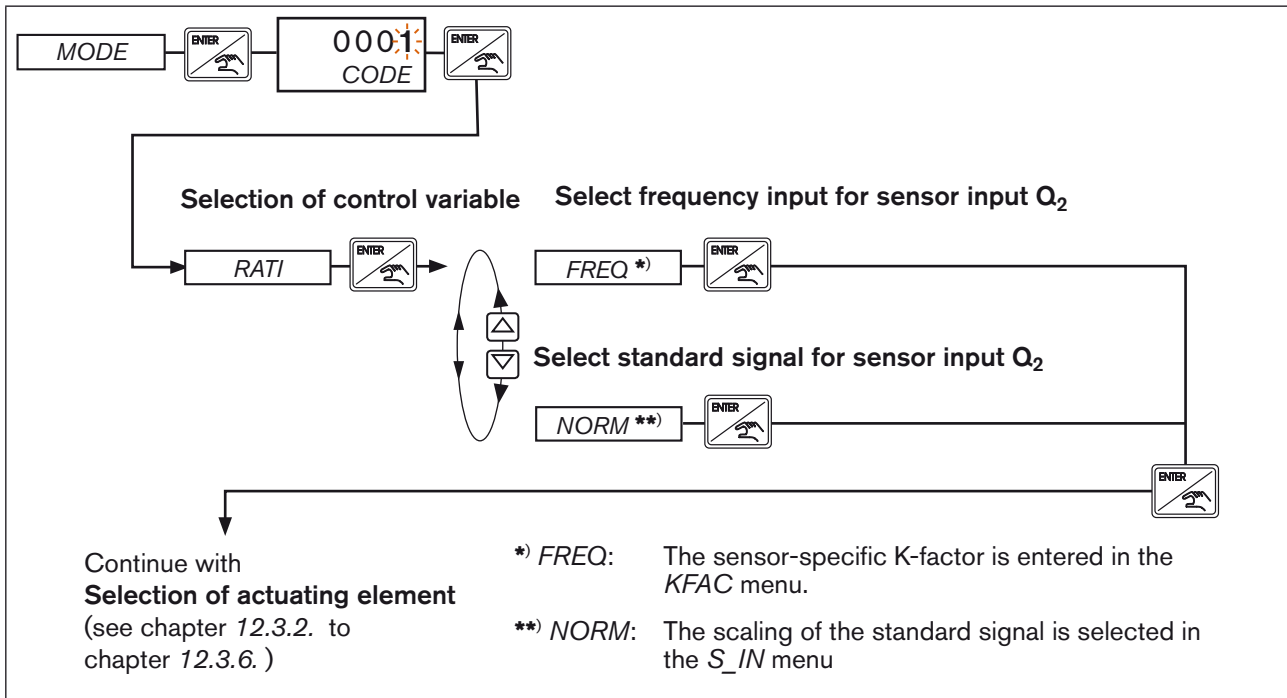

Figure 29: *RATI*; Setting the ratio control

Particularity of the control cabinet model!

In the control cabinet model, the standard signal input is available for Q_1 in addition to the frequency input. However, for the inputs Q_1 and Q_2 , a standard signal (*NORM*) can only be assigned once. If the standard signal was selected for sensor input Q_2 (*MODE*, *RATI*, *NORM*) only frequency is available when selecting the process value input Q_1 .

Example:

| Selection of sensor input Q_2 | Selection option for process value input Q_1 |
|---------------------------------|--|
| <i>FREQ</i> (frequency) | <i>FREQ</i> (frequency) or <i>NORM</i> (standard signal) |
| <i>NORM</i> (standard signal) | <i>FREQ</i> (frequency) |

Table 15: Select *NORM*/*FREQ* for sensor input and process value input

Schematic representation:

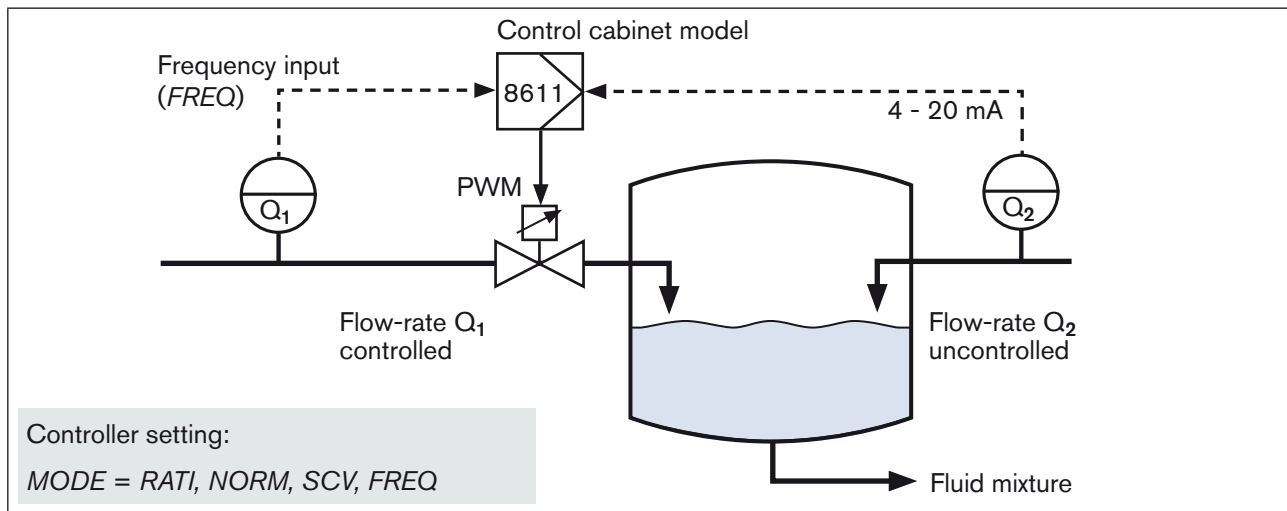

Figure 30: Schematic representation; Ratio control using control cabinet model of Type 8611

12.3.2. SCV - Continuous control using proportional valve

The settings of the eCONTROL Type 8611 are made in this menu if a proportional valve is used. It is very important and crucial for a good control that the control frequency (PWM frequency) is set according to the selected valve type.

Technical explanations:

- Relation between valve type and control frequency
Depending on the orifice and the fluidic performance data, the individual valve types include magnetic coils that greatly differ in terms of manufactured size, coil data and dynamic properties.
The magnetic force of the coil and the selected control frequency influence the responsiveness of the valve and the related dither movement.
- Interaction of magnetic force, frequency and dither movement
The ability to respond to a PWM signal with a small dither movement and thus to ensure a particularly good responsiveness of the valve greatly depends on the dynamic parameters of the coil.

The following is generally applicable:

- Small coils with a low magnetic force still respond well to higher frequencies.
In low frequencies, they produce an unnecessarily high noise level due to excessive movement amplitudes.
- Large coils with a high magnetic force respond less well to higher frequencies.
In low frequencies, they still produce dither movements thus ensuring sliding friction states.

- Responsiveness
The response of a valve to a PWM signal not only depends on its frequency but also on the current pulse duty factor τ and the working point.
The valve responds more sensitively if the working point is within medium pulse duty factors ($\tau \sim 50\%$) and more sluggishly if the opening corresponds to a pulse duty factor in the border areas close to 0% or close to 100%. To compensate for this dependency, controlling is executed at a variable PWM frequency that depends on the pulse duty factor and the progression of which follows a triangular function.
In this regard, the frequency is lowest at the border points (0%, 100%) and highest at $\tau = 60\%$.
(see Figure 31:)

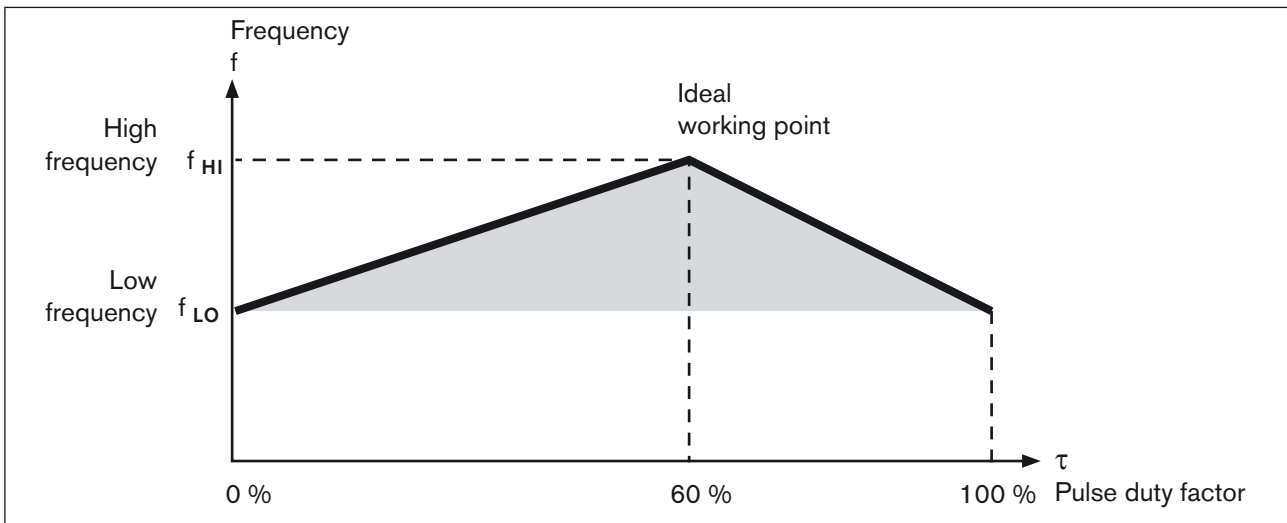

Figure 31: PWM frequency / pulse duty factor



Note for easy setting of the PWM frequency

All Bürkert proportional valves with the corresponding PWM frequency are saved in the menu of the eCONTROL Type 8611 and can be selected there (see Table 16:).

By setting the valve type, the two limit frequencies of the PWM control (f_{HI} and f_{LO}) are set. Depending on the working point, the actual output frequency is in this range. The values allocated to the valve types (see Table 16:) were determined empirically from the behavior of a large number of individual devices of the respective type.

For optimizing the control behavior, the pulse duty factor is limited depending on the valve type as there are no significant changes in the flow-rate in the upper range of the pulse duty factor (see Table 16:).



WARNING!

Danger due to malfunction if an incorrect valve type is selected!

Selecting the wrong valve type may result in damage at the valve and in malfunction.

- Ensure that you select the right valve type.

Selectable Bürkert proportional valves with the respective PWM frequencies:

| Valve type | PWM frequency [Hz] | | | Maximum controlling frequency |
|------------|--------------------|------------------------|-------------------------|-------------------------------|
| | Medium frequency | Low frequency f_{LO} | High frequency f_{HI} | |
| 2821 | 725 | 650 | 800 | 90 % |
| 2822 | 1100 | 1000 | 1200 | 90 % |
| 2824 | 900 | 800 | 1000 | 90 % |
| 2832 | 350 | 300 | 400 | 90 % |
| 2833 | 700 | 600 | 800 | 90 % |
| 2834 | 230 | 180 | 280 | 90 % |
| 2835 | 450 | 400 | 500 | 90 % |
| 2836 | 165 | 150 | 180 | 85 % |
| 6021 | 725 | 650 | 800 | 90 % |

| Valve type | PWM frequency [Hz] | | | Maximum controlling frequency |
|------------|--------------------|------------------------|-------------------------|-------------------------------|
| | Medium frequency | Low frequency f_{LO} | High frequency f_{HI} | |
| 6022 | 350 | 300 | 400 | 90 % |
| 6023 | 230 | 180 | 280 | 90 % |
| 6024 | 230 | 180 | 280 | 90 % |
| 6223 | 230 | 180 | 280 | 90 % |

Table 16: Selection of Bürkert proportional valves / PWM frequency for control / maximum controlling frequency

Setting the PWM frequency in the menu:

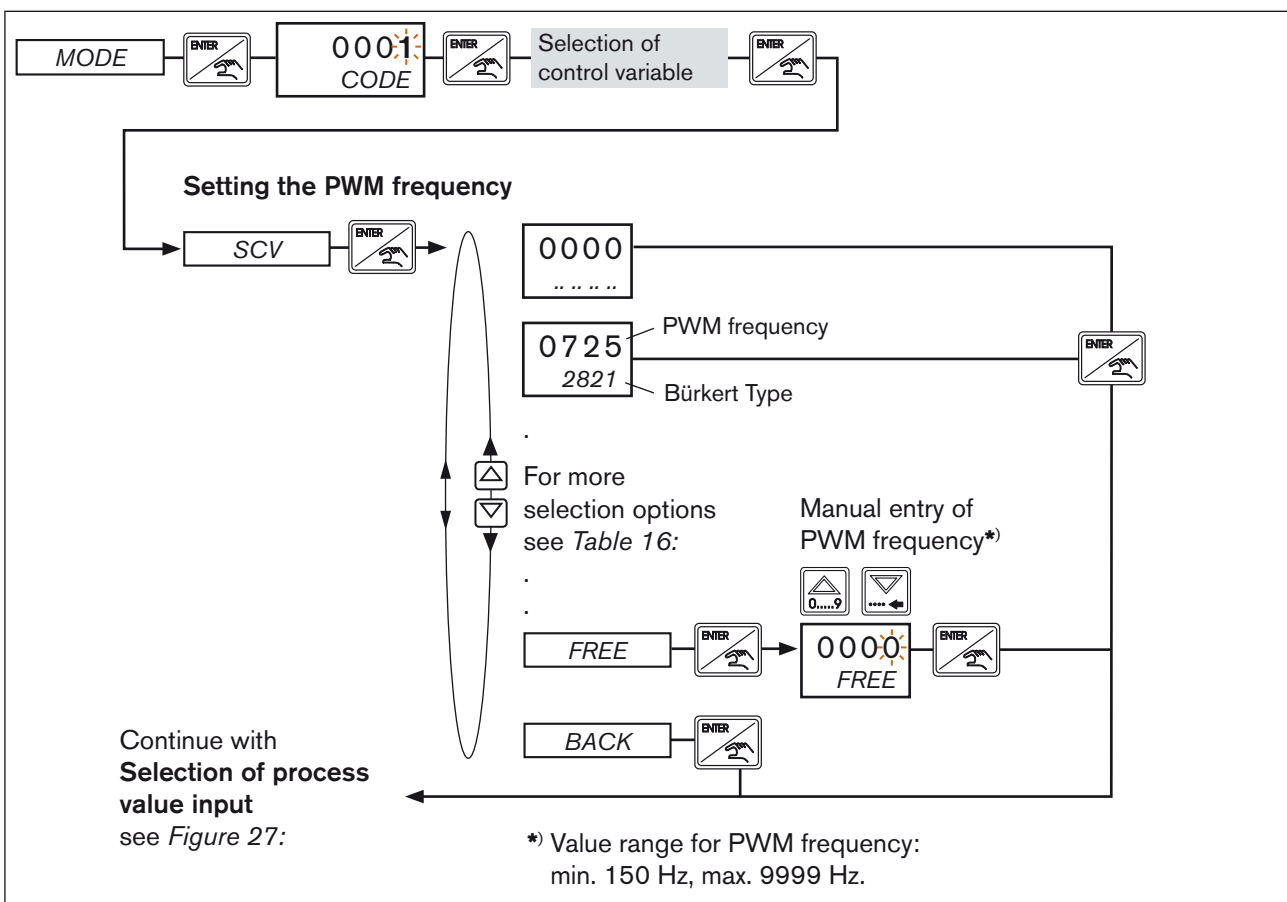

Figure 32: SCV; Setting the PWM frequency for controlling proportional valves

Schematic representation:

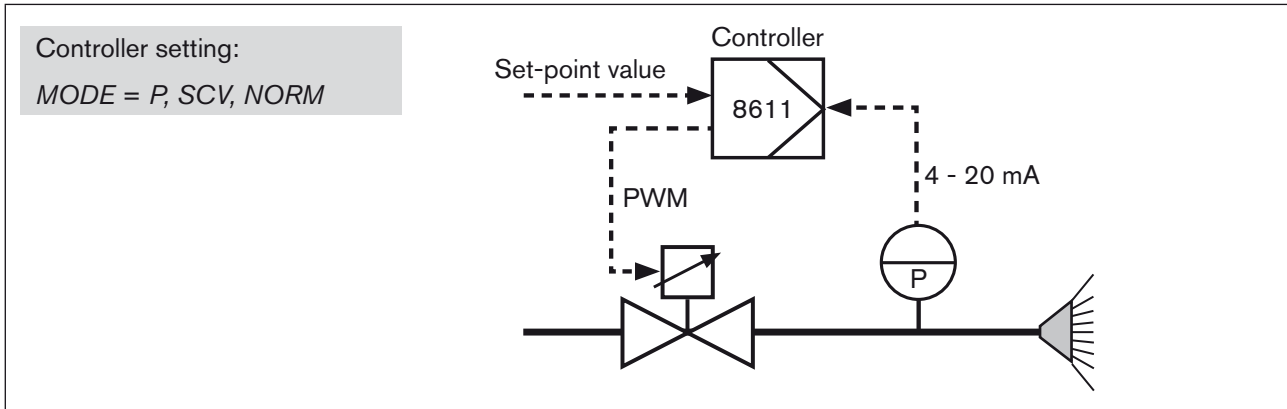

Figure 33: Pressure control using proportional valve

12.3.3. PCV - Quasi-continuous control using process valve

Use: Using this function, it is possible to implement the control of a process valve without position feedback. This is in particular interesting if the process valve cannot be designed with position feedback due to rough process conditions (e.g. high temperature, high humidity, little space requirement).

Parameterization: Single-acting, pneumatically operated control valves with "normal closed" function can be operated. Two control valves are required for the pneumatic control of the process valve (see Figure 34:).

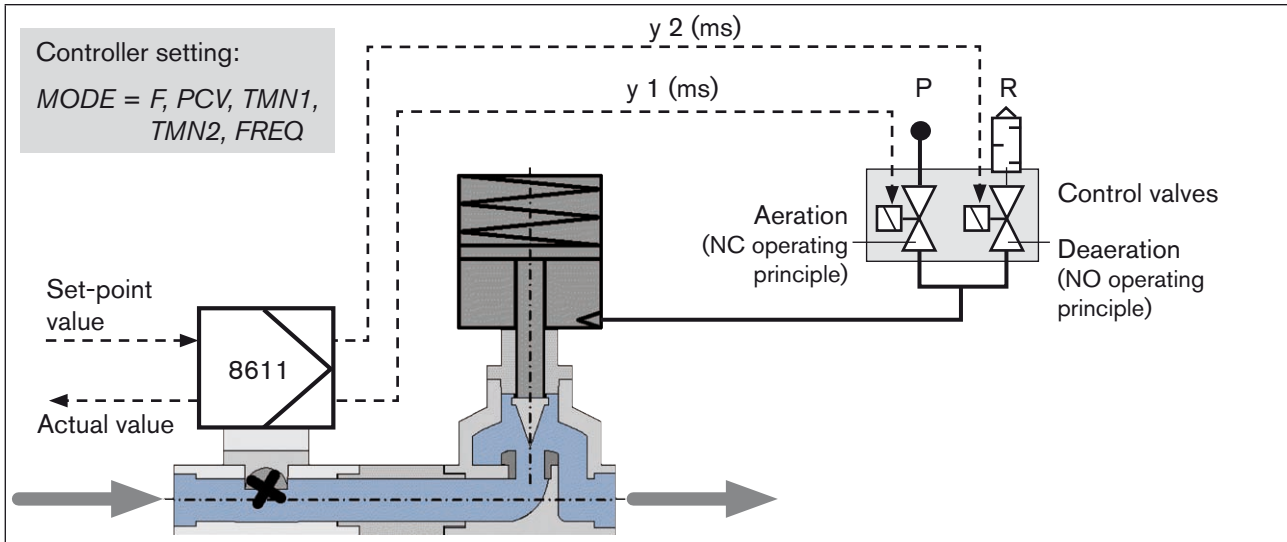

Figure 34: Example of a quasi-continuous control using process valve

The process valve is opened and closed with two control valves. The control valve for aeration opens and that for deaeration closes the process valve.

A 3-state controller with P-structure is provided as controller, which calculates a time-proportional control (PTM) as manipulated variable for the control valves depending on the set-point/actual value deviation.

By default, the control valves are available as control block (Bürkert Type 8810) for the control of 1, 2, 4 or 6 process valves. The design for the control of a process valve is shown in Figure 35: .

For optimal control of process valves, the opening and closing times must be set in the PCV menu by setting the minimum control time:

| Display | Description | Control time [ms] | |
|---------|---|-----------------------------------|--|
| | | Bürkert control blocks Type 8810 | Other valves |
| TMN1 | Minimum control time for aeration valve in ms | 5 ms (default) (0 ... 9999 ms) | Use the times specified in the data sheet of the valve |
| TMN2 | Minimum control time for bleed valve in ms | 5 ms (default) (0 ... 9999 ms) | |

Table 17: Minimum control time for control valves

The minimum control time describes the time within that the control valve just starts opening.

! For the Bürkert control blocks Type 8810, the minimum control time of 5 ms has been set as default in the controller and does not have to be changed.

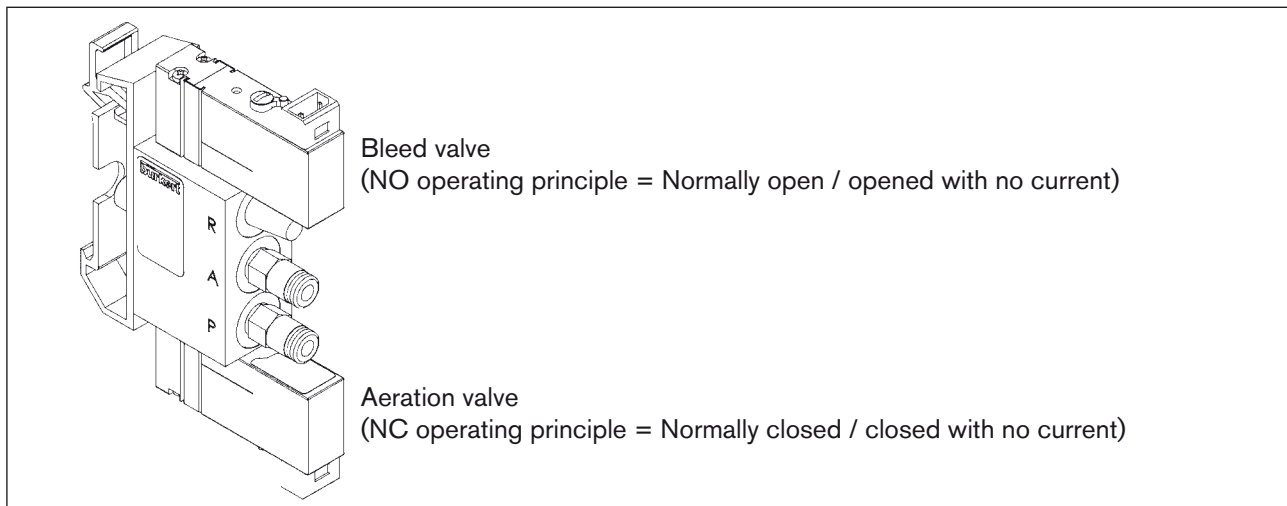

Figure 35: Control block 8810 for control of the process valve

If control valves other than those of Type 8810 are used, the opening time specified in the data sheet for "TMN1" or the closing time for "TMN2" can be used.

To ensure that the process valve moves automatically into closed position in the event of a power failure, observe the operating principle of the control valves:

- Control valve for aeration = NC operating principle / Normally closed (closed with no current)
- Control valve for deaeration = NO operating principle / Normally Open (opened with no current)

Setting the minimum control time in the menu:

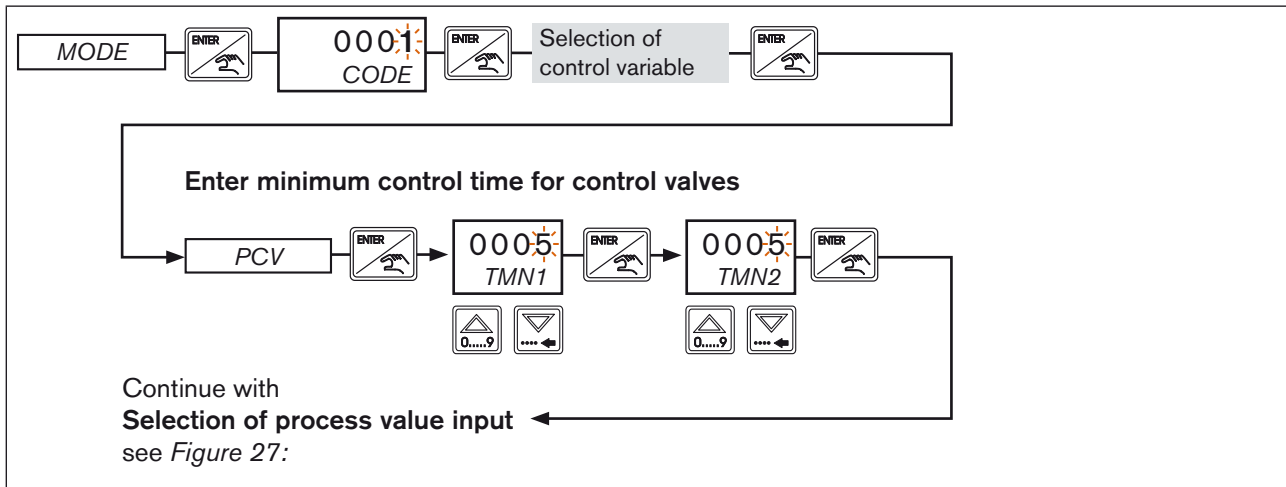

Figure 36: PCV; Enter minimum control time for control valves

12.3.4. 4-20 / 0-10 - Continuous control with 4 - 20 mA or 0 - 10 V standard signal

This function can be used for operating control valves (e.g. motor valve, positioner) via the analog output using the control for 4-20mA or alternatively 0-10V standard signal.

Example of a typical use, the flow-rate control in conjunction with a flow-rate sensor and an electric motor control valve, see Figure 37: .

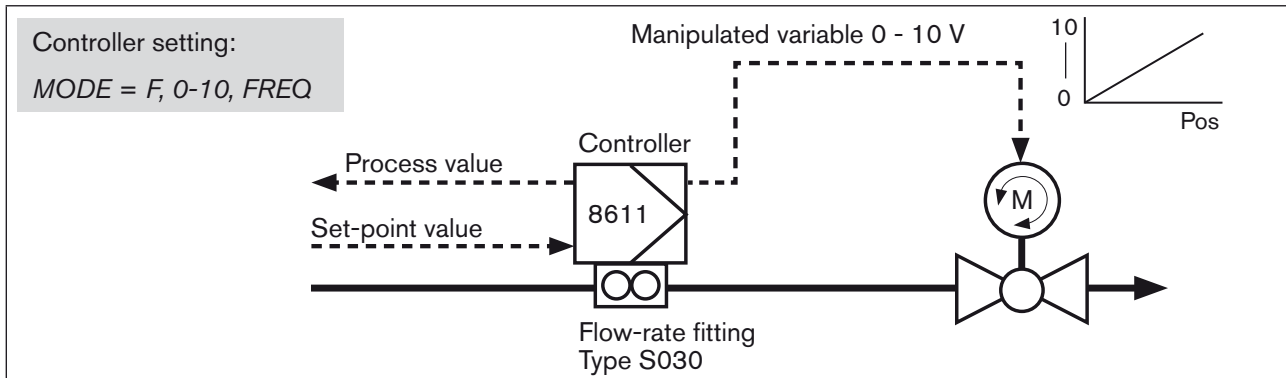

Figure 37: Example of a flow-rate control with 0 - 10 V control

Setting the continuous control with standard signal in the menu:

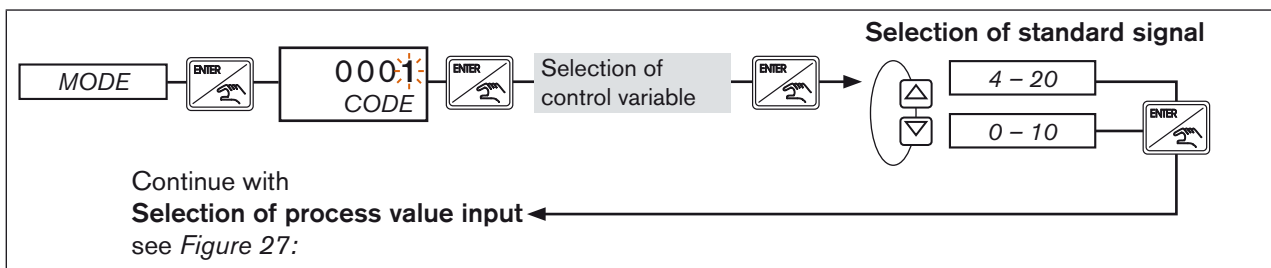

Figure 38: MODE; Setting the standard signal

MAN 1000094736 EN Version: G Status: RL (released / freigegeben) printed: 13.01.2011

12.3.5. 2P – T - Quasi-continuous 2-state control with open/closed valves

This function can be used to implement quasi-continuous controls using open/closed valves.

Here, unlike in purely open/closed controls that only provide for the states open or closed, the control time for the opening or closing is varied proportionally to the set-point/actual value deviation. The valves are controlled via the transistor output of the controller.

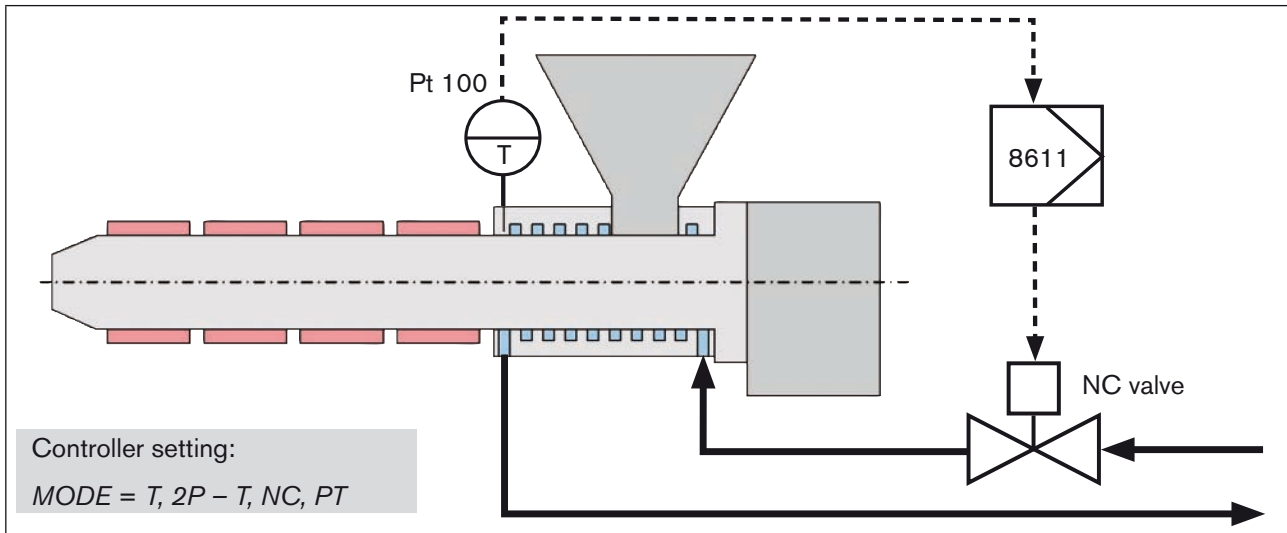

Figure 39: Example of a 2-state temperature control with open/closed valve

Setting the quasi-continuous 2-state control in the menu:

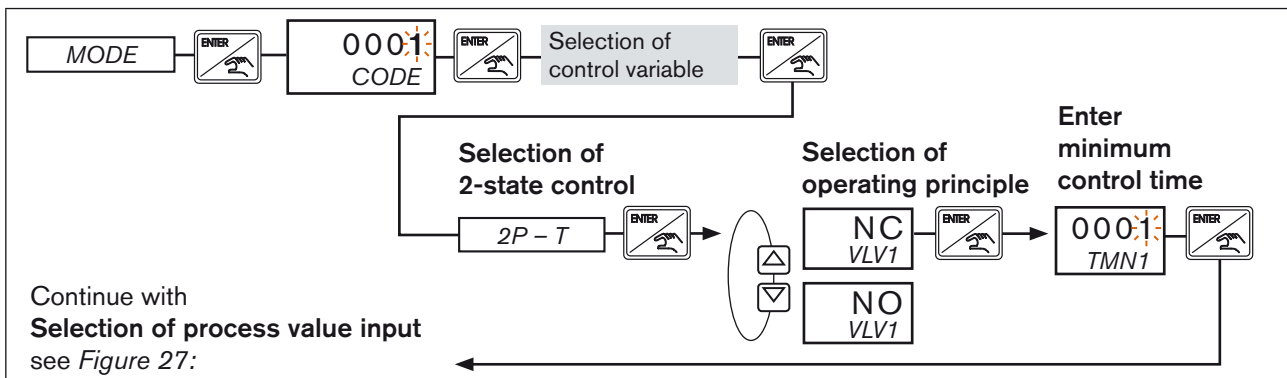

Figure 40: 2P – T; 2-state control / operating principle

| Display | Description |
|---------|--|
| 2P – T | Quasi-continuous 2-state control with time-proportional control for opening and closing. |
| VLV1 | Control of valve 1 (output BO3) |
| NC | Valve with operating principle "closed with no current" (normally closed). |
| NO | Valve with operating principle "opened with no current" (normally open). |
| TMN1 | Minimum control time in ms |

Table 18: Display 2P – T; quasi-continuous 2-state control / operating principle

12.3.6. 3P - T - Quasi-continuous 3-state control with open/closed valves or motor valve

This function can be used to implement quasi-continuous controls using open/closed valves or motor valves.

Here, unlike in purely open/closed controls that only provide for the states open or closed, the control time for the opening or closing is varied proportionally to the set-point/actual value deviation. The valves are controlled via 2 transistor outputs of the controller.

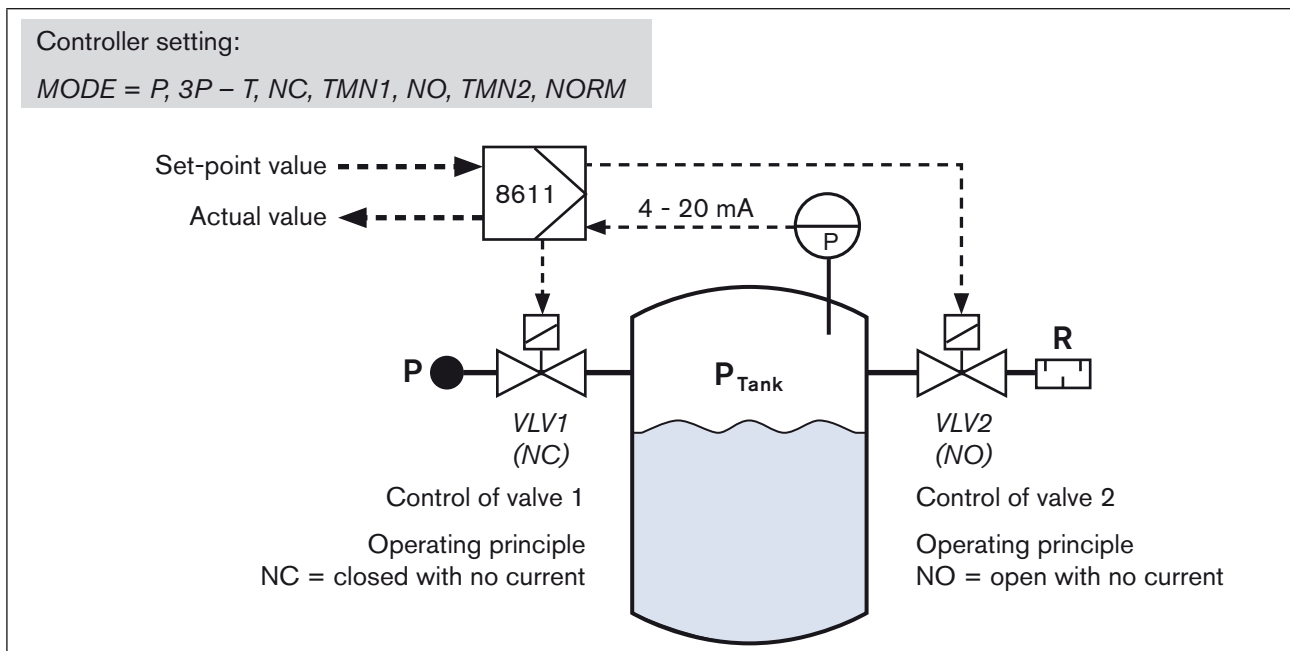

Figure 41: Example of a three-state pressure control

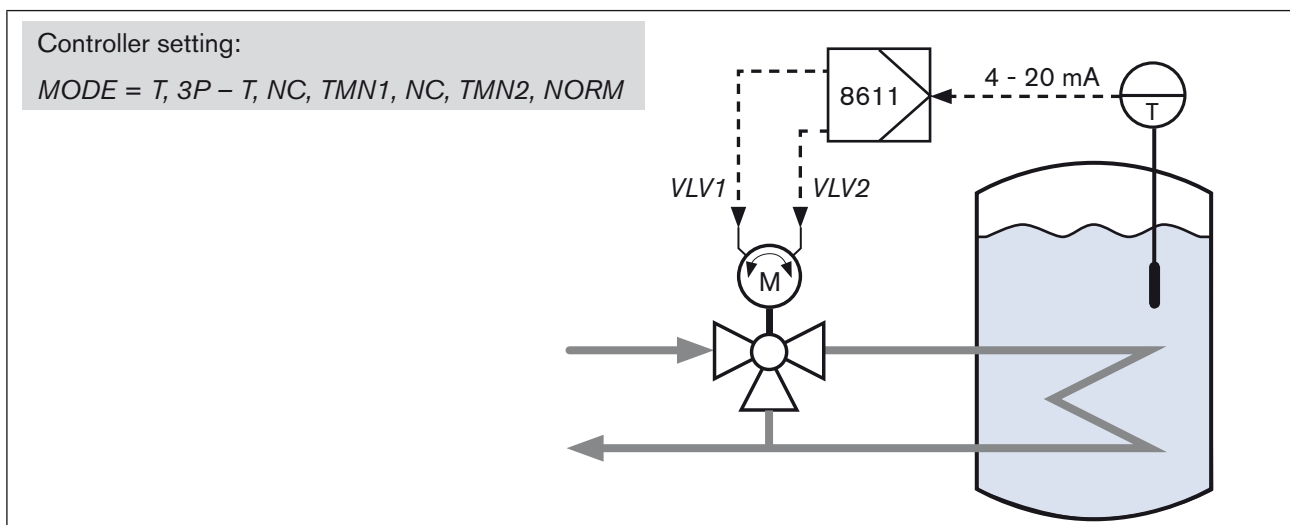

Figure 42: Example of a three-state temperature control

Setting the quasi-continuous 3-state control in the menu:

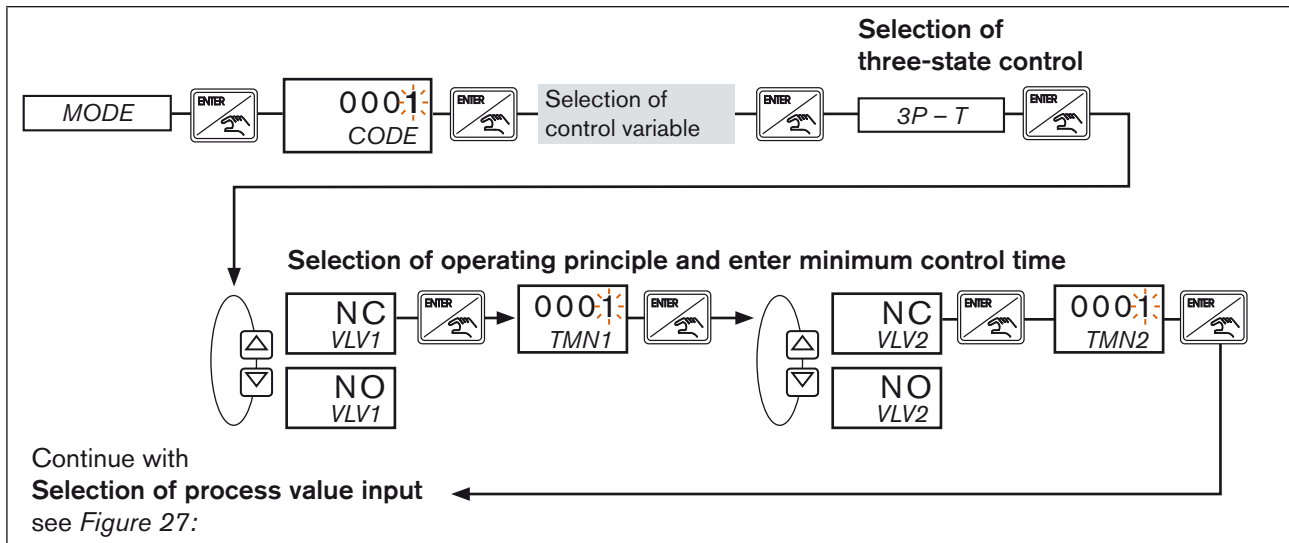

Figure 43: 3P – T; 3-state control / operating principle

| Display | Description |
|---------|--|
| 3P – T | Quasi-continuous 3-state control with time-proportional control for opening and closing. |
| VLV1 | Control of valve 1 or "Open" motor valve (output BO3) |
| VLV2 | Control of valve 2 or "Close" motor valve (output BO4) |
| NC | Valve with operating principle "closed with no current" (normally closed). In the event of a motor drive, the NC operating principle must be set for both VLV1 and VLV2. |
| NO | Valve with operating principle "opened with no current" (normally open). |
| TMN1 | Minimum control time of valve 1 in ms. |
| TMN2 | Minimum control time of valve 2 in ms. |

Table 19: Display 3P – T; quasi-continuous 3-state control / operating principle

12.4. UNIT - Selection of measuring units and decimal places

In this menu option, the measuring units and the number of decimal places (see *Table 20:*) are selected for the displayed values.

! What measuring unit is selected in the *UNIT* menu depends on the control variable set in the *MODE* menu.

Selecting the measuring unit and decimal places in the menu:

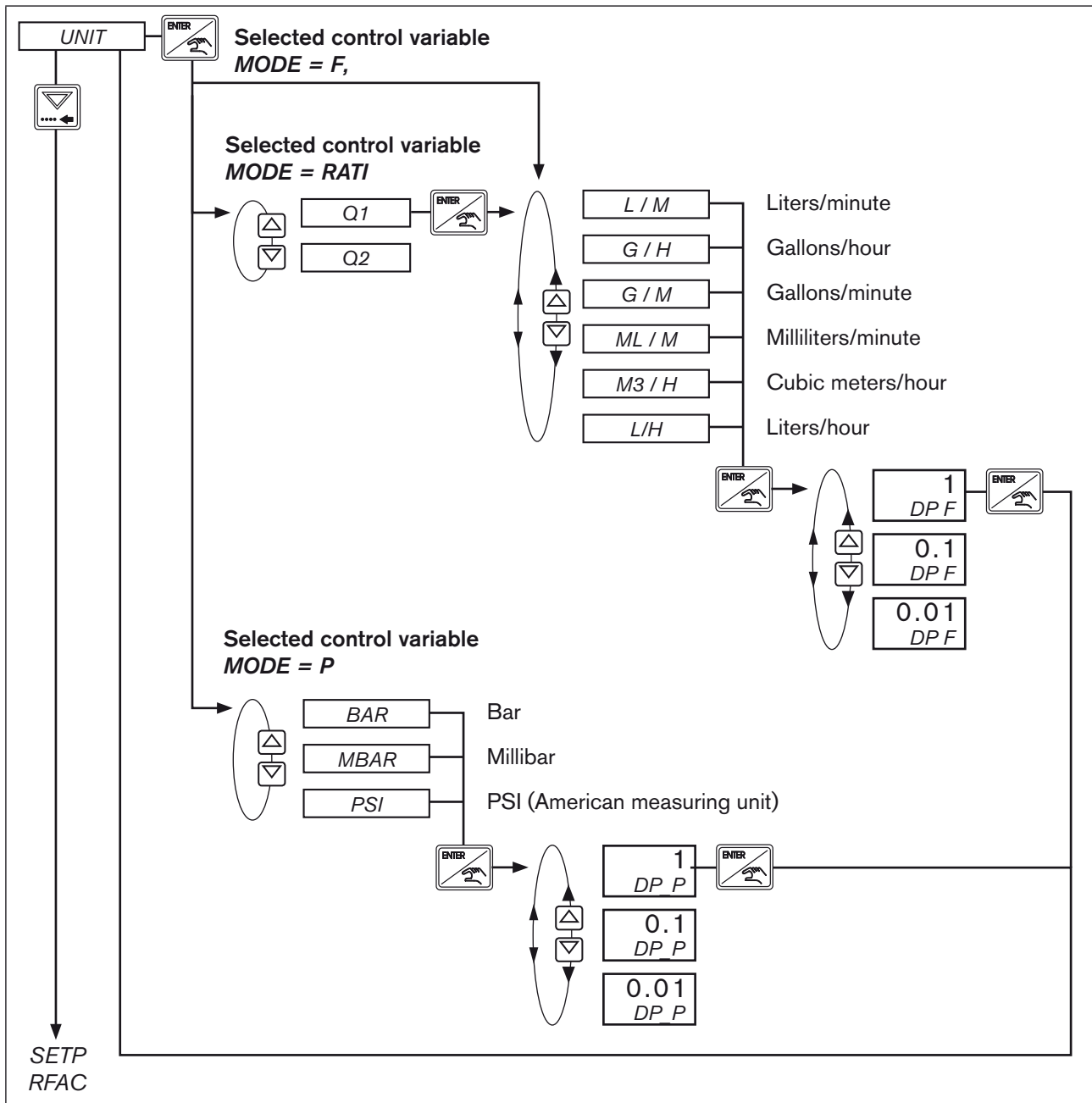

MAN 1000094736 EN Version: G Status: RL (released | freigegeben) printed: 13.01.2011

Figure 44: UNIT; Selecting the measuring unit and decimal places for control variable *MODE = RATI*, *MODE = F*, *MODE = P*

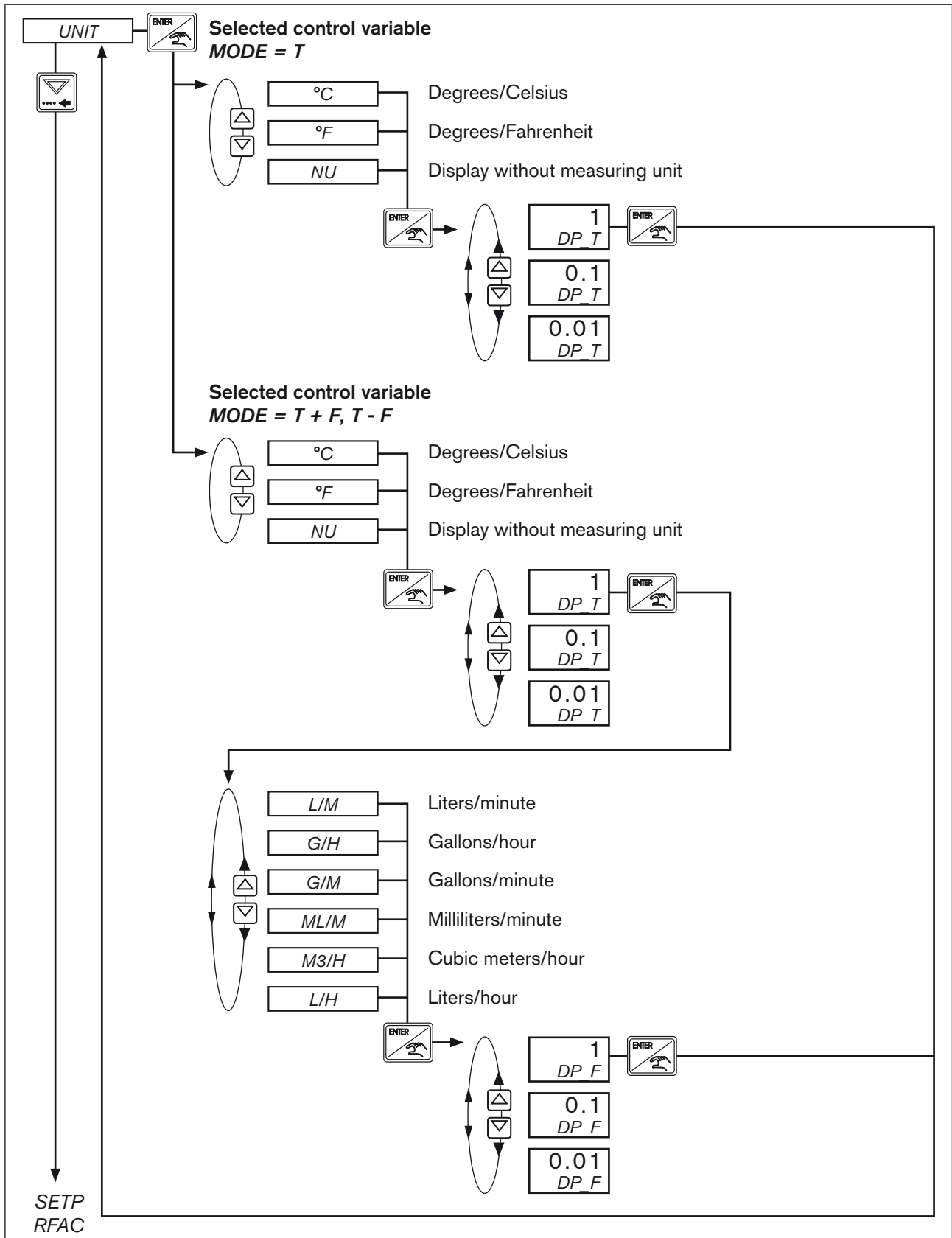

Figure 45: UNIT; Selecting the measuring unit and decimal places for control variable MODE = T, MODE = T+F, MODE = T-F

MAN 1000094736 EN Version: G Status: RL (released / freigegeben) printed: 13.01.2011

MAN 1000094736 EN Version: G Status: RL (released | freigegeben) printed: 13.01.2011

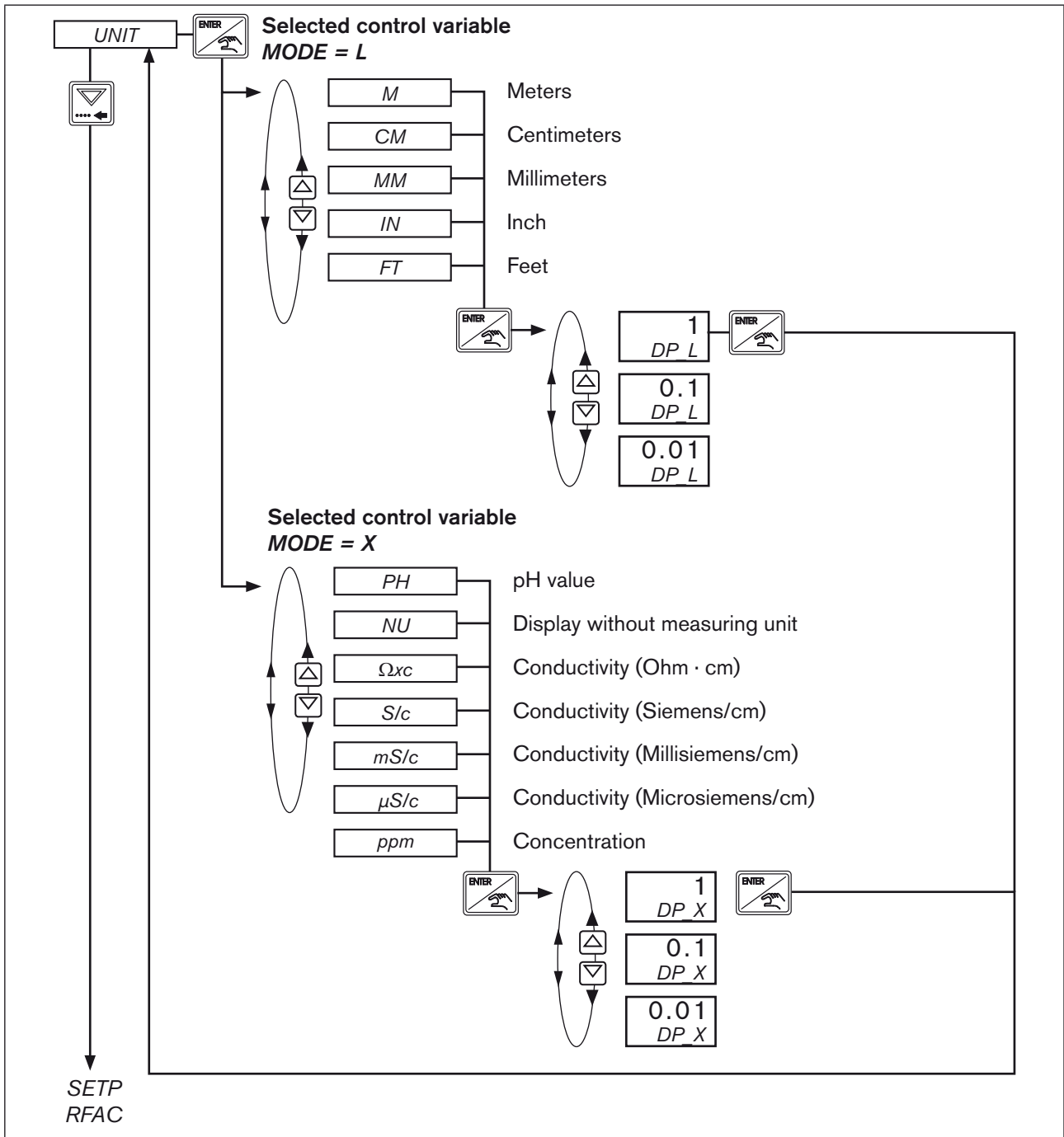

Figure 46: UNIT; Selecting the measuring unit and decimal places for control variable MODE = L, MODE = X

Selecting the decimal places:

| Display | Description |
|---------|--------------------|
| 1 | No decimal places |
| 0.1 | One decimal place |
| 0.01 | Two decimal places |

Table 20: Selecting the decimal places

12.5. SETP / RFAC - Selection and scaling of set-point value default / entry of ratio factor

When selecting the set-point value default, the display in the menu makes a distinction between the set-point value for the process control and the set-point value for the ratio control.

In the case of process control, the *SETP* menu is displayed for the setting; in the case of ratio control the *RFAC* menu.

! Set-point value for the process control (SETP):
The process control applies for all control variables set in the *MODE* menu except for the control variable *RATI*.

The ratio factor (RFAC) is entered as set-point value for the ratio control:
For the ratio control, the control variable *RATI* must be set in the *MODE* menu.

For both control types, it is possible to select in the menu whether the set-point value is specified internally (INT) using the keys or externally (EXT) using a standard signal.

! If external set-point value default was selected, this is indicated by a 1 on the display (see chapter 9.1.1. *Display elements*).

At the process operating level and in the operating state *MANUAL*, the internal set-point value default is specified using the following menus:

SET for the process control (see chapter 11.5. *SET - Set-point value default for process control*)

RFAC for the ratio control (see chapter 11.6. *RFAC - Ratio factor default for ratio control*)

Settings in the menu for process control (*SETP*):

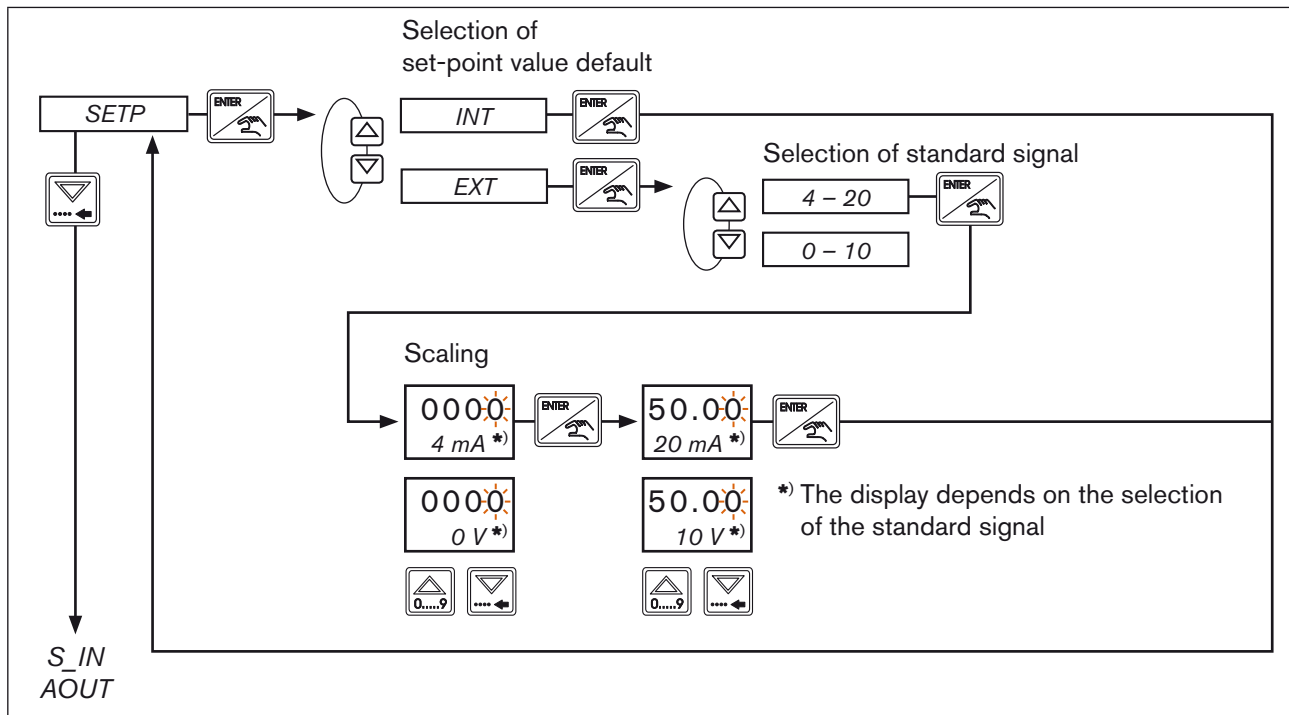

Figure 47: *SETP*; Setting the set-point value default and scaling for process control

| Display SETP | Description |
|--------------|--|
| INT | Internal set-point value default. Is entered in the operating state MANUAL in the SET menu using the keyboard. See chapter 11.5. SET - Set-point value default for process control |
| EXT | External process set-point value default using standard signal (4 - 20 mA or 0 - 10 V). |
| 4 mA / 20 mA | Scaling of 4 - 20 mA standard signal (for definition of decimal places see UNIT menu). |
| 0 V / 10 V | Scaling of 0 - 10 V standard signal (for definition of decimal places see UNIT menu). |

Table 21: Display SETP

Setting in the menu for ratio control (RFAC):

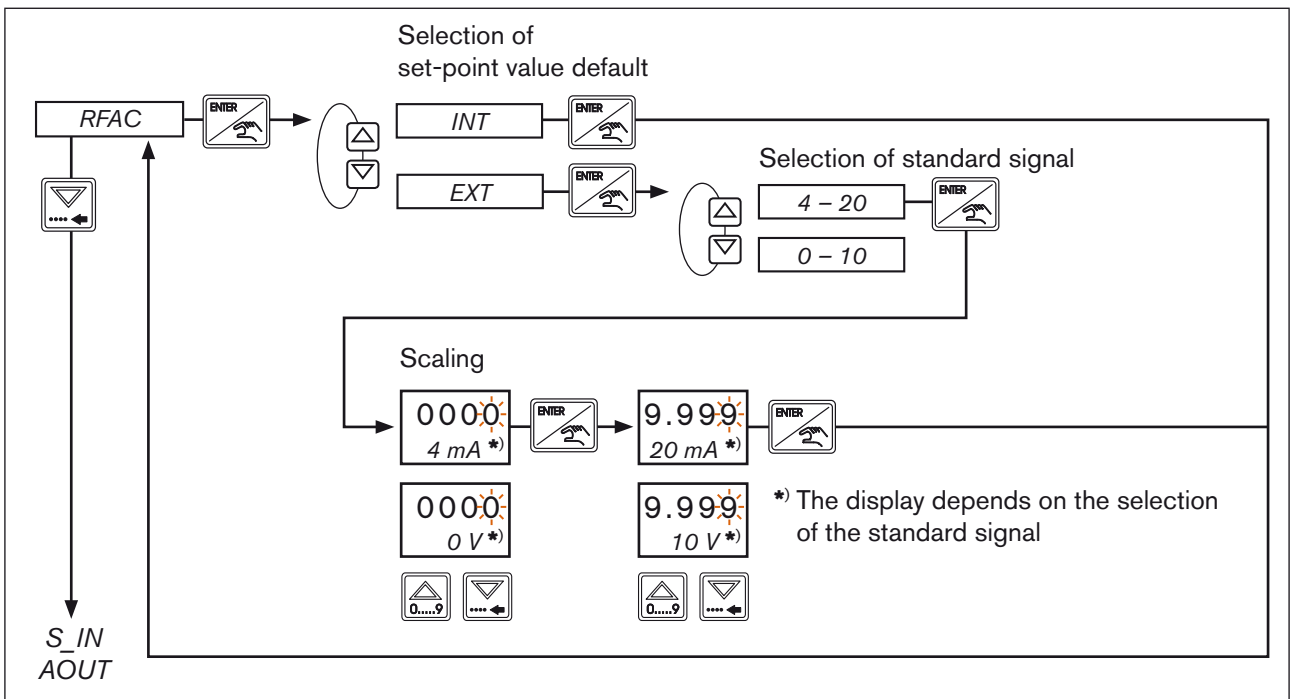

Figure 48: RFAC; Setting the ratio factor

| Display RFAC | Description |
|--------------|--|
| INT | Internal ratio factor default. Is entered in the operating state MANUAL in the RFAC menu using the keyboard. See chapter 11.6. RFAC - Ratio factor default for ratio control. Value range: 0.000 to 9.999 |
| EXT | External ratio factor default (RFAC) using standard signal (4 - 20 mA or 0 - 10 V). |
| 4 mA / 20 mA | Scaling of 4 - 20 mA standard signal (value range: 0.000 - 9.999). |
| 0 V / 10 V | Scaling of 0 - 10 V standard signal (value range: 0.000 - 9.999). |

Table 22: Display RFAC

! The decimal place for the ratio factor RFAC is fixed and cannot be changed.

MAN 1000094736 EN Version: G Status: RL (released / freigegeben) printed: 13.01.2011

12.6. S_IN - Scaling of sensor input signal (4 - 20 mA or 0 - 10 V)



The S_IN menu is only displayed if an analog sensor input was selected in the MODE menu.

Setting in the menu:

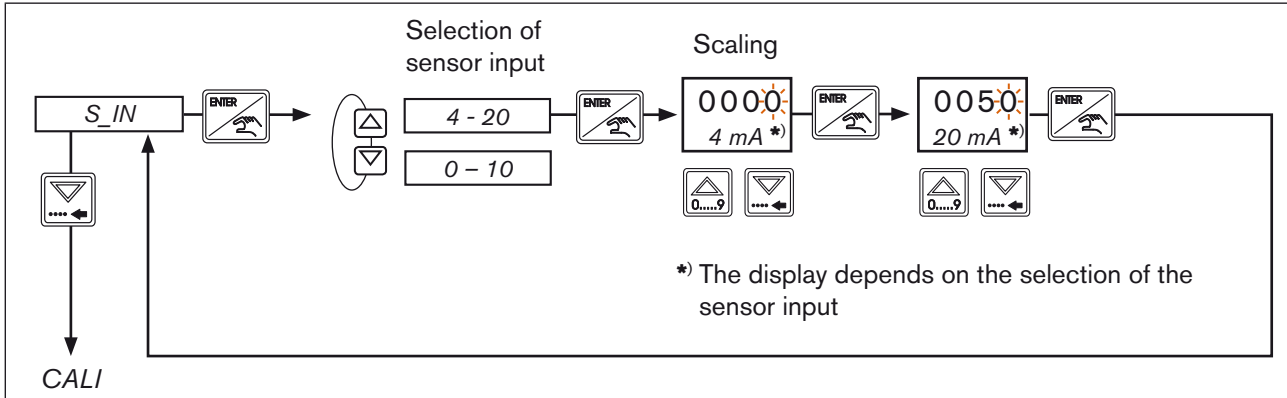

Figure 49: S_IN; Scaling of the sensor input signal

| Display | Description |
|---------|---|
| 4 - 20 | Selection of 4 - 20 mA as sensor input 4 mA: Entry of display value for 4 mA 20 mA: Entry of display value for 20 mA |
| 0 - 10 | Selection of 0 - 10 V as sensor input 0 V: Entry of display value for 0 V 10 V: Entry of display value for 10 V Value range: Display value for 4 mA / 0 V < display value for 20 mA / 10 V or display value for 20 mA / 10 V < display value for 4 mA / 0 V |

Table 23: Display S_IN

12.7. AOUT - Scaling of analog output (4 - 20 mA or 0 - 10 V)

The analog output is selected and scaled in this menu.

! The AOUT menu is not displayed if, in the MODE menu, 4 - 20 or 0 - 10 was selected as actuating element. See chapter 12.3. MODE - Selection of control variable, actuating element and process value input.

Setting in the menu:

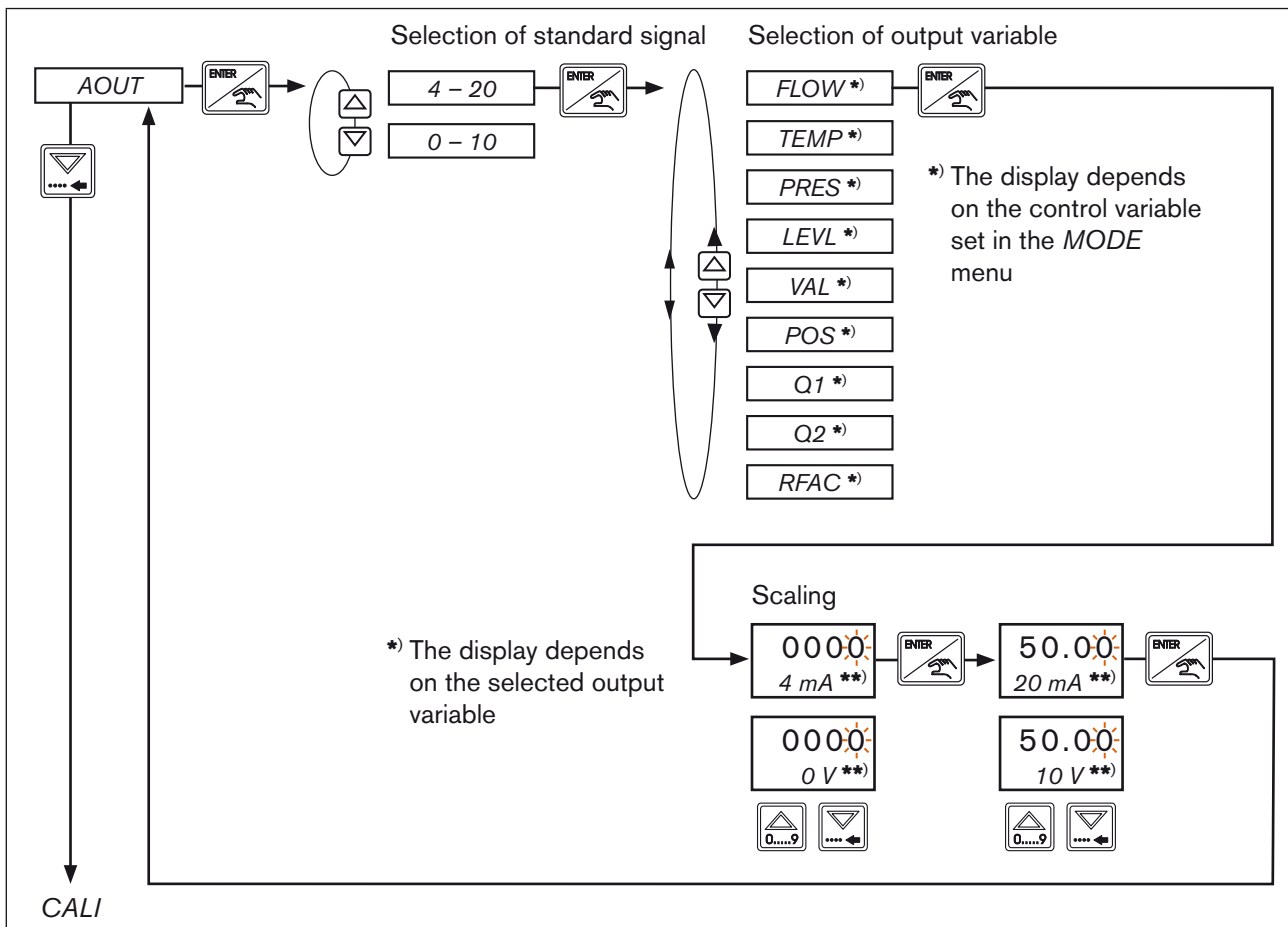

Figure 50: AOUT; Scaling of the analog output

| Display | Description |
|---------|--|
| 4 - 20 | Selection of 4 - 20 mA standard signal output |
| 0 - 10 | Selection of 0 - 10 V standard signal output |
| FLOW | Output of flow-rate as standard signal (only for control variable $MODE = F, T + F, T - F$) |
| TEMP | Output of temperature as standard signal (only for control variable $MODE = T, T + F, T - F$) |
| PRES | Output of pressure as standard signal (only for control variable $MODE = P$) |
| LEVL | Output of filling level (only for control variable $MODE = L$) |
| VAL | Output of process value (only for control variable $MODE = X$ or T and $UNIT = NU$) |

MAN 1000094736 EN Version: G Status: RL (released | freigegeben) printed: 13.01.2011

| Display | Description |
|--------------|---|
| POS | Output of actuating element position (only for actuating element type <i>MODE = SCV</i>) Value range: 000.0 - 100.0 000.0 = valve closed 100.0 = valve open |
| Q1 | Output of flow-rate Q1 for ratio control (control variable <i>MODE = RATI</i>) |
| Q2 | Output of flow-rate Q2 for ratio control (control variable <i>MODE = RATI</i>) |
| RFAC | Output of ratio factor <i>RFAC</i> for ratio control (control variable <i>MODE = RATI</i>) Scaling: Fixed scaling between 0.000 and 9.999. |
| 4 mA / 20 mA | Scaling of 4 - 20 mA output signal. 4 mA: Entry of output value for 4 mA 20 mA: Entry of output value for 20 mA Value range: Output value for 4 mA < output value for 20 mA or output value for 20 mA < output value for 4 mA |
| 0 V / 10 V | Scaling of 0 - 10 V output signal. 0 V: Entry of output value for 0 V 10 V: Entry of output value for 10 V Value range: Output value for 0 V < output value for 10 V or output value for 10 V < output value for 0 V |

Table 24: Display AOUT

12.8. CALI - Calibration of the analog inputs and outputs

NOTE!

Impaired function due to incorrect calibration.
The calibration must be done by trained staff only

All analog inputs and outputs were calibrated at the factory prior to delivery of the controller Type 8611. However, it is possible to recalibrate the analog inputs and outputs for services purposes or for checking the calibration.

Setting in the menu:

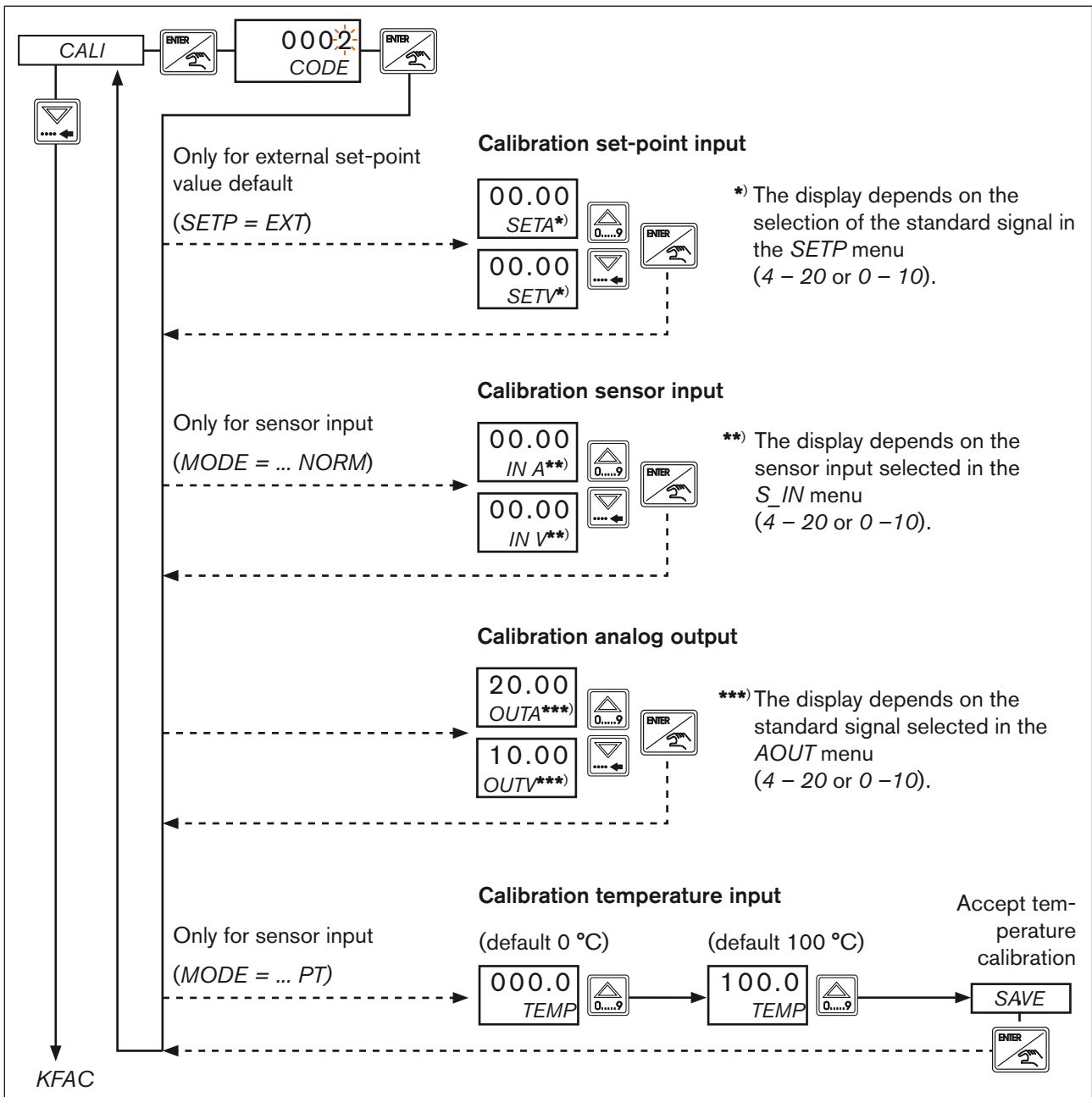

MAN 1000094736 EN Version: G Status: RL (released | freigegeben) printed: 13.01.2011

Figure 51: CALI; Calibration of the analog inputs and outputs

12.9. Calibration of the assembly models: Wall, rail, valve or fitting assembly





| Menu | Description | Circular plug-in connector | Pin | External circuit |
|------------------------------|---|---|----------------|---|
| <i>SETA</i> , <i>SETV</i> | Use standard signal transmitter to apply a defined voltage (max. 10 V) or defined current (max. 20 mA), as shown in the columns on the right. Use the arrow keys to change the displayed value until the display corresponds to the default. | M 12, 8-pole  | 5 (+) 7 (-) |  |
| <i>IN A</i> , <i>IN V</i> | Apply defined current to sensor input, as shown in the columns on the right. Use the arrow keys to change the displayed value until the display corresponds to the default. | M 8, 3-pole  | 4 (+) 3 (-) |  |
| <i>OUTA</i> , <i>OUTV</i> | Connect multimeter to circular plug-in connector, as shown in the columns on the right, and measure the current and voltage value. Use the arrow keys to change the current or voltage value until 20 mA or 10 V are displayed on the multimeter. | M 12, 8-pole  | 6 (-) 4 (+) |  |
| | | Wall assembly (only identification number 182383) M 8, 4-pole  | 2 (-) 4 (+) |  |
| <i>TEMP</i> | Use standard signal transmitter to apply a temperature of 0 °C or a resistance of 100 Ω, as shown in the columns on the right. Press the up arrow key to accept the value. Increase temperature value to 100 °C or resistance to 138.506 Ω. Press the up arrow key to accept the value. Confirm the <i>SAVE</i> display with the ENTER key to save the measurement. | M 8, 3-pole  | 4 3 |  |

Table 25: Calibration of the assembly models: Wall, rail, valve or fitting assembly

12.10. Calibration of the control cabinet model

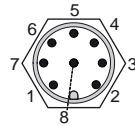
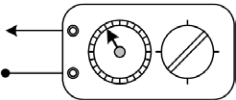
| Menu | Description | Terminals | External circuit |
|-------------------------------------|--|--|---|
| <p><i>SETA</i>, <i>SETV</i></p> | <p>Use standard signal transmitter to apply a defined voltage (max. 10 V) or defined current (max. 20 mA), as shown in the columns on the right.</p> <p>Use the arrow keys to change the displayed value until the display corresponds to the default.</p> | <p>14 21</p>  <p>14 (+) 21 (-)</p> |  |
| <p><i>IN A</i>, <i>IN V</i></p> | <p>Apply defined current to sensor input, as shown in the columns on the right.</p> <p>Use the arrow keys to change the displayed value until the display corresponds to the default.</p> | <p>21 22</p>  <p>22 (+) 21 (-)</p> |  |
| <p><i>OUTA</i>, <i>OUTV</i></p> | <p>Connect multimeter to terminals, as shown in the columns on the right, and measure the current and voltage value.</p> <p>Use the arrow keys to change the current or voltage value until 20 mA or 10 V are displayed on the multimeter.</p> | <p>9 10</p>  <p>9 10</p> |  |
| <p><i>TEMP</i></p> | <p>Use standard signal transmitter to apply a temperature of 0 °C or a resistance of 100 Ω to the terminals, as shown in the columns on the right. Press the up arrow key to accept the value.</p> <p>Increase temperature value to 100 °C or resistance to 138.506 Ω. Press the up arrow key to accept the value.</p> <p>Confirm the <i>SAVE</i> display with the <i>ENTER</i> key to save the measurement.</p> | <p>19 20</p>  <p>19 20</p> |  |

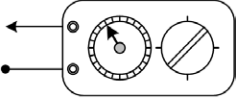
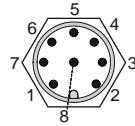
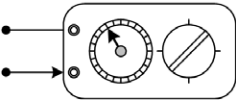
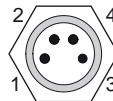
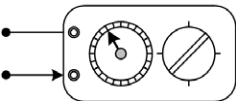
Table 26: Calibration of the control cabinet model

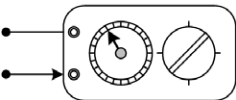
MAN 1000094736 EN Version: G Status: RL (released | freigegeben) printed: 13.01.2011

12.11. KFAC - Entry of K-factor for flow-rate measurement

The controller Type 8611 only displays the *KFAC* menu if entry of the K-factor is required.

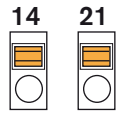
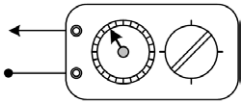
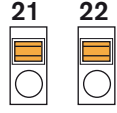
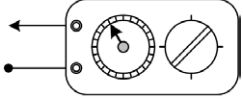
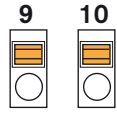
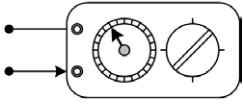
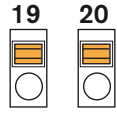
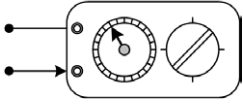
This is the case if a sensor with frequency input was selected. (*MODE*, selection of process value input, *FREQ*. See Chapter 12.3.).

In the controller Type 8611, the respective K-factor is already pre-set for the sensors from Bürkert. Once the type and the flow-rate variable have been selected, the corresponding K-factor is displayed and confirmed with the ENTER key.

Selecting the *FREE* menu option also allows for individual, i.e. type-independent entry of the K-factor.

Entry of the K-factor for ratio control (*MODE = RATI*):

If frequency input was selected for both flow-rate sensors for ratio control, one of the inputs must be selected for the entry of the K-factor. When the menu is started, the selection *Q1* and *Q2* is displayed.

For ratio control see chapter 12.3.1. *RATI - Selection of external sensors for ratio control*.

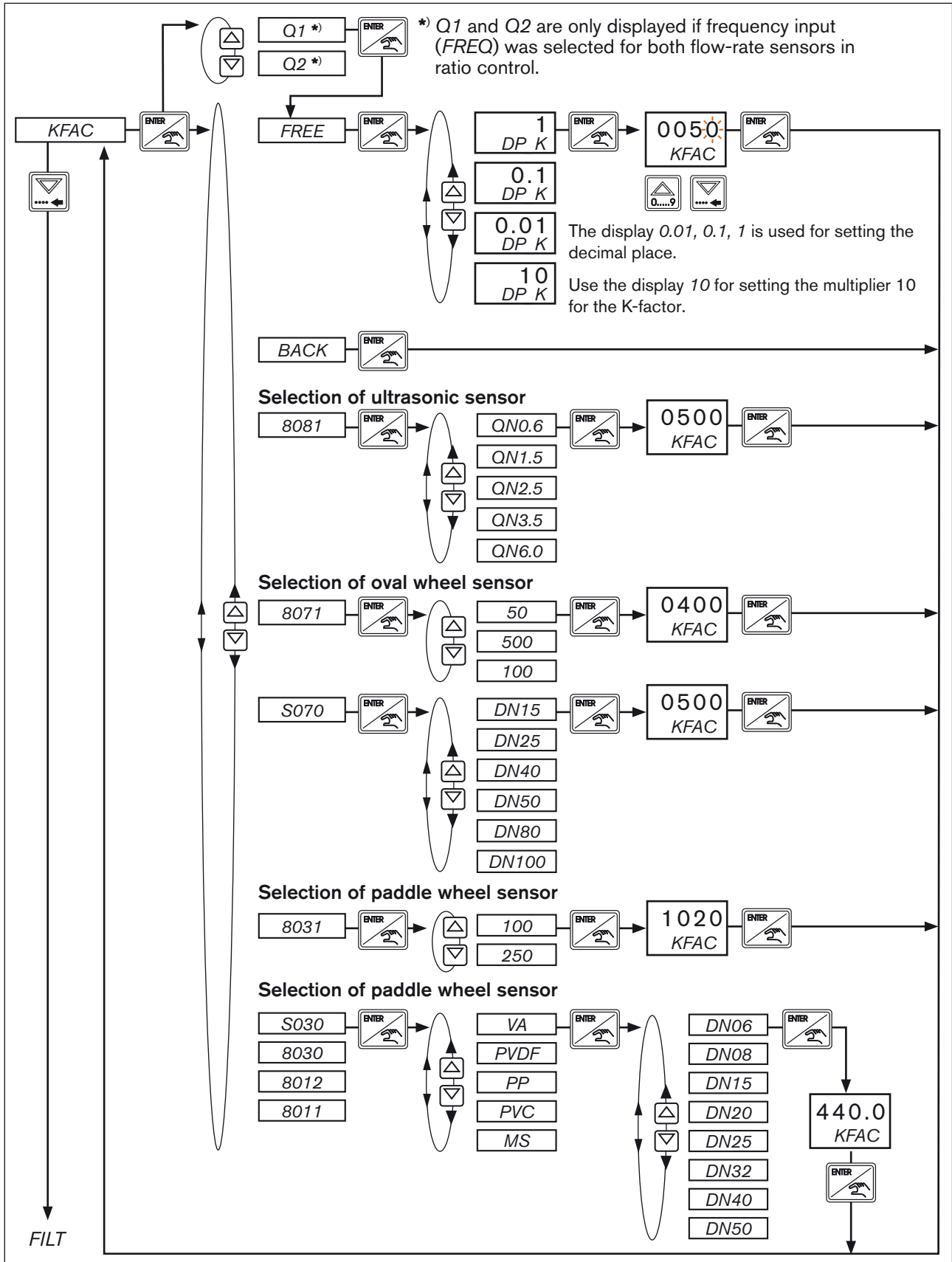

MAN 1000094736 EN Version: G Status: RL (released | freigegeben) printed: 13.01.2011

Figure 52: K FAC; entry of K-factor

12.12. *FILT* - Filtering of the process actual value input

Factory setting: *FILT* = 08

Value range: 2 - 20

The process actual value input is prepared via a digital FIR filter for the control or for the analog process value output. The behavior of such filter corresponds to an analog filtering using an RC element. The time behavior of the filtering differs depending on the measuring signal (frequency signal or analog signal).

12.12.1. Filtering analog inputs (4 - 20 mA, 0 - 10 V, Pt 100)

The analog measurement values are scanned at a sampling frequency of 300 Hz, the resulting sampling rate amounts to 3.33 ms

The time behavior of the measurement value depending on the filtering depth is shown in the figure below.

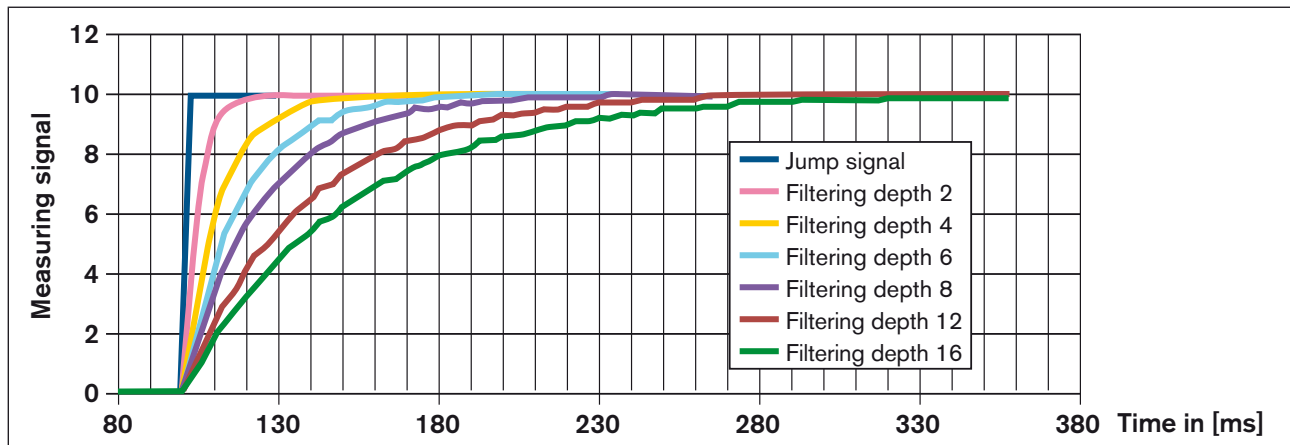

Figure 53: Filtering of the analog measurement values depending on different filtering depths

The T_{90} time as response to a jump signal can be estimated as follows:

$$T_{90} = 2.2 \times \text{sampling rate (3.33 ms)} \times \text{filtering depth} = 7.3 \text{ ms} \times \text{filtering depth}$$

12.12.2. Filtering frequency inputs

For frequency inputs, the sampling frequency for filtering the flow-rate value varies. It depends on the selected flow-rate sensor. The typical output frequencies for the Bürkert flow-rate sensor range between 10Hz and 200 – 300 Hz. The measured period T_p serves as the measure for estimating the T_{90} time. Based on this period, the T_{90} time can be estimated as follows:

$$T_{90} = 2.2 \cdot \text{period} \cdot \text{filtering depth}$$

The following table contains a list of the frequency range (f_{\min} - f_{\max}) and the period (T_p) for the Bürkert flow-rate sensors that are stored in the eCONTROL Type 8611. Sampling frequencies under f_{\min} are automatically detected by the eCONTROL Type 8611 as zero flow-rate.

| Sensor type | 8011, 8012, 8030, S030 | 8031 | S070 | 8071 | 8081 | FREE |
|---|------------------------|----------|-----------|-----------|------------|------------|
| Frequency range [Hz] f_{\min} - f_{\max} | 3 - 255 | 15 - 283 | 1 - 72 | 0,5 - 55 | 0,5 - 666 | 0,5 - 2000 |
| Period [ms] T_p | 333 - 4 | 66 - 3,5 | 1000 - 14 | 2000 - 18 | 2000 - 1,5 | 2000 - 0,5 |

Table 27: *FILT*, frequency range and period of Bürkert flow-rate sensors

12.13. *PARAMETER* - Adjusting the controller parameters

In this menu, the following parameters can be set for the eCONTROL Type 8611:

- Proportional coefficient (proportional gain for opening and closing the actuating element) KP_1 , KP_2
The influence that the proportional coefficient has with regard to the selected actuating element and how the proportional gain is calculated are described in the following chapter 12.13.1. *KP1, KP2 - Setting the proportional coefficient (proportional gain)*.
- Controller cycle time $TREG$
- Reset time TN , TN_T
- Dead zone $DEAD$, DE_T
- Effective direction between process value and valve position INV
- Zero point shut-off $ZERO$
- Defining the start value $STRT$



What controller parameters are displayed for setting in the *PARAMETER* menu depends on the actuating element selected in the *MODE* menu. See chapter 12.3. *MODE - Selection of control variable, actuating element and process value input*.

Setting the controller parameters in the menu:

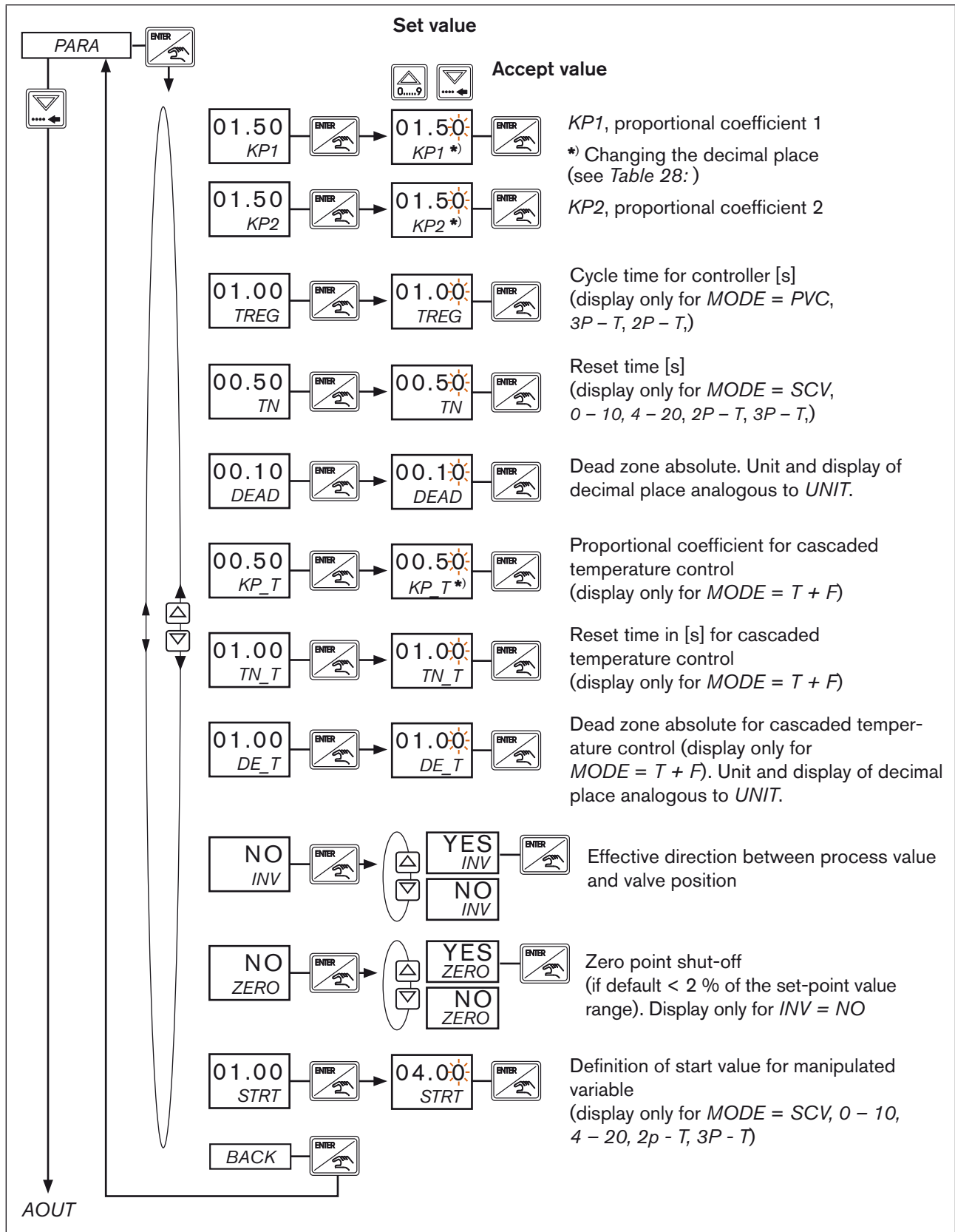

Figure 54: PARA; Adjusting the controller parameters

12.13.1. KP1, KP2 - Setting the proportional coefficient (proportional gain)

Depending on the actuating element selected in the *MODE* menu (see chapter 12.3.), the influence of the proportional coefficient varies. It serves as proportional gain [K_P] either for opening or for closing the actuating element.

Calculation of the proportional gain [K_P]:

Calculation for continuous control (*MODE* = *SCV*, *4 - 20* or *0 - 10*):

The proportional gain is calculated by dividing the value for the manipulated variable change [Δ%] by the value for the process value change [ΔPV].

$$K_P = \frac{\Delta\%}{\Delta PV} \begin{matrix} \text{Manipulated variable change} \\ \text{Process value change} \end{matrix}$$

Depending on the selected actuating element in the *MODE* menu the manipulated variable is scaled as follow:

| | | |
|-----------------------------|---------------------------------|--|
| <i>MODE</i> = <i>SCV</i> | 0 % = Pulse duty factor 0 % | 100 % = Pulse duty factor 100 % (relatively to PWM-frequency) |
| <i>MODE</i> = <i>0 - 10</i> | 0 % = Manipulated variable 0 V | 100 % = Manipulated variable 10 V |
| <i>MODE</i> = <i>4 - 20</i> | 0 % = Manipulated variable 4 mA | 100 % = Manipulated variable 20 mA |
| <i>MODE</i> = <i>2P - T</i> | 0 % = Valve closed | 100 % = Valve (VLV1) open in relatio to time T _{REG} (T _{REG} = 100 %) |
| <i>MODE</i> = <i>3P - T</i> | 0 % = Valve 1 closed | 100 % = Valve 1 (VLV1) in relatio to time T _{REG} (T _{REG} = 100 %) |
| | 0 % = Valve 2 closed | -100 % = Valve 2 (VLV2) in relatio to time T _{REG} (T _{REG} = 100 %) |
| <i>MODE</i> = <i>PCV</i> | 0 % = Valve 1 closed | 100 % = Valve 1 (VLV1) in relatio to time T _{REG} (T _{REG} = 100 %) |
| | 0 % = Valve 2 closed | -100 % = Valve 2 (VLV2) in relatio to time T _{REG} (T _{REG} = 100 %) |

Speciality: The controller operates as a discontinuous 2-state controller or 3-state controller if in the *MODE* menu as actuating element *2P - T* or *3P - T* is selected and the proportional gain K_P is set to 9999 (independent from decimal place). The parameters T_{REG} and T_N have no influence to the control..

The influence of the proportional value on the actuating element and the calculation of the proportional gain:

| Actuating element (selection in <i>MODE</i> =) | Influence proportional coefficient | Calculation of the proportional gain [K _P] | Value range |
|--|---|--|---|
| <i>SCV</i> <i>4 - 20</i> <i>0 - 10</i> | Proportional gain K _{P1} for opening and closing the actuating element | $K_{P1} = \frac{\Delta\%}{\Delta PV}$ | 0.001 – 9999 Changing the decimal places → Press the ENTER key to select KP1 or KP2. |
| <i>PCV</i> <i>2P - T</i> <i>3P - T</i> | Proportional gain K _{P1} for opening the actuating element | $K_{P1} = \frac{\Delta\%}{\Delta PV}$ | → Use the arrow key to move to the left until the decimal place flashes. |
| <i>PCV</i> <i>3P - T</i> | Proportional gain K _{P2} for closing the actuating element | $K_{P2} = \frac{\Delta\%}{\Delta PV}$ | → Now use the up arrow key to position the decimal place at the correct place and confirm with ENTER. |

Table 28: KP1, KP2 - Proportional gain

MAN 1000094736 EN Version: G Status: RL (released / freigegeben) printed: 13.01.2011



If the selected unit is changed in the *UNIT* menu, the proportional gain $[K_P]$ must be adapted accordingly.



Setting aid:

An unsatisfactory dynamic of the control is improved by increasing the proportional gain $[K_P]$. The following must be observed:

In the event of impermissibly high overshoots after set-point value jumps or in the event of an unstable control, the proportional gain $[K_P]$ should be reduced.

12.13.2. Examples for the setting and calculation of the proportional gain $[K_P]$

SCV - Pressure control using proportional valve

(For schematic representation see *Figure 33: Pressure control using proportional valve*)

Technical description:

- The control of the proportional valve is restricted to between 20 % and 90 %.
The control range of the valve is restricted as follows: *VALV*, *MIN* = 20 %, *MAX* = 90 % (see chapter 12.17. *VALV - Test function and setting of the control range*).
The physical control range thus takes place between 20% and 90% of the valve position. The defined physical range is set in the controller as 100%.
- The process value change amounts to 250 mbar.

Calculation for K_{P1} :

$$K_{P1} = \frac{100 \%}{250 \text{ mbar}} = 0,4 \%/\text{mbar}$$

PCV - Quasi-continuous flow-control using process valve

(For schematic representation see *Figure 34: Example of a quasi-continuous control using process valve*)

Technical description:

- Bürkert process valve with actuator size 50 mm.
- The max. process value change between closed and open position of the valve amounts to 50 l/min.
- The flow change is done within the opening time of the valve. The opening time amounts of about 2 s (see *Table 29: Valve opening times for Bürkert process valves*).
- The control range of the valve is not restricted: *VALV*, *MIN* = 0, *MAX* = 0 (see chapter 12.17. *VALV - Test function and setting of the control range*).

Calculation for K_{P1} and K_{P2} :

$$K_{P1} = \frac{100 \%}{50 \text{ l/mn}} = 2 \% / \text{l/mn}$$

The proportional coefficient for opening can also be used for closing.

The controller cycle time T_{REG} can be set between 1 - 2 s. For slow control loops like temperature control T_{REG} must be increased.

Overview of the valve opening times of the Bürkert process valves depending on the actuator size and pilot pressure:

| Actuator size [DN] | Pilot pressure | Opening time for valve [s] | Closing time for valve [s] |
|--------------------|----------------|----------------------------|----------------------------|
| 50 | 6 | 2 | 2 |
| | 5 | | |
| | 4 | | |
| 63 | 6 | 2 | 3 |
| | 5 | 3 | |
| | 4 | 4 | |
| 80 | 6 | 4 | 5 |
| | 5 | 5 | |

Table 29: Valve opening times for Bürkert process valves

0 - 10 - Flow-rate control with motor valve and 0 - 10 V control

(For schematic representation see *Figure 37: Example of a flow-rate control with 0 - 10 V control*)

Technical description:

- Motor ball valve with 0 - 10 V control.
- The max. process value change between closed and open position of the valve amounts to 20 l/min.
- The control range of the valve is not restricted: $VALV, MIN = 0, MAX = 10$ (see chapter 12.17. *VALV - Test function and setting of the control range*).
- According to the manufacturer, the opening and closing time are 90 s each.

Calculation for K_{P1} :

$$K_{P1} = \frac{100\%}{20 \text{ l/min}} \cdot 100 = 5\% / (\text{l/min})$$

The opening or closing time for the valve is taken into consideration by the reset time T_N . As start value for T_N about 60 - 70 % of the valve opening time can be taken.

2P - T - Temperature control with open/closed valve

(For schematic representation see *Figure 39: Example of a 2-state temperature control with open/closed valve*)

Technical description:

- Solenoid valve.
- The process value change between closed and continuously opened position of the valve amounts to 10 °C.
- The time for the temperature change amounts to 20 s.

Calculation for K_{P1} :

$$K_{P1} = \frac{100\%}{10\text{ °C}} = 10\% / \text{°C}$$

- The reset time T_N can be set between 15 - 20 s.
- With the controller cycle time T_{REG} the switching frequency of the valve can be influenced.
Recommendation: $T_{REG} = 0.5 - 0.25 T_N$



Setting aid:

An unsatisfactory dynamic of the control is improved by increasing the proportional gain $[K_P]$. The following must be observed:

In the event of impermissibly high overshoots after set-point value jumps or in the event of an unstable control, the proportional gain $[K_P]$ should be reduced.

12.13.3. TREG – Setting the controller cycle time

This parameter is only available if quasi-continuous actuating parameters have been selected ($MODE = PCV, 2P - T$ or $3P - T$).

$TREG$ defines the cycle time in seconds in that a set-point/actual value comparison is regularly executed and a new manipulated variable is calculated. Within this time the pilot valve will be switched one time.

The parameter $TREG$ has to be set in that way to get an acceptable life time of the valve on the one side and to avoid an tolerable oscillation of the process value on the other side.

The parameter $TREG$ should be smaller than the reset time $[T_N]$

12.13.4. TN – Setting reset time

With this parameter the I-portion of continuous or quasi-continuous control loops can be set.

The reset time $[T_N]$ in seconds is the time that is required to obtain an equally large change in the manipulated variable by the I portion, as occurs due to the P portion.

The time it takes for getting about 60 - 70 % of the process value change can be taken as an start value for T_N .

T_N can be selected between 0.01 and 999.9 s. When 999.9 is set, the I-portion is deactivated (independent from decimal place).

12.13.5. DEAD – Insensitivity range (dead zone)

This function causes the process controller to respond only from a specific control difference. This protects the control valves.

The dead zone is entered as an absolute value according to the unit selected in the $UNIT$ menu.

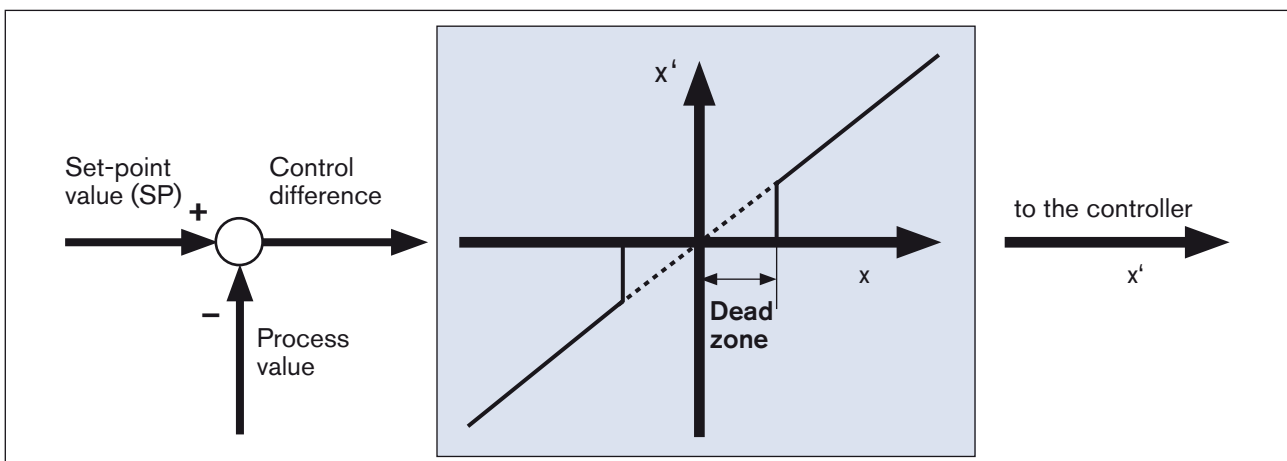

Figure 55: DEAD; Insensitivity range (dead zone)

MAN 1000094736 EN Version: G Status: RL (released / freigegeben) printed: 13.01.2011

12.13.6. KP_T – Proportional gain of the cascaded temperature control

This parameter is only available if the $MODE = T + F$ process variable is selected and describes the proportional gain of the superimposed temperature controller. In the cascaded temperature control, the flow-rate control serves as subsidiary control circuit.

The proportional gain KP_T is scaled as follows:

$$K_{PT} = \frac{\Delta PV \text{ (flow-rate change in accordance with the unit selected in } UNIT)}{\Delta ^\circ K \text{ (temperature change)}}$$



Setting aid:

For starting up the cascaded controller, it is purposeful to optimize only the flow-rate measurement first. The corresponding setting in the menu:

- Set KP_T (proportional coefficient for the cascaded temperature control) to 0.0
- Set TN_T (reset time in [s] for cascaded temperature control) to 999.9

This switches off the temperature control.

The set-point value of the temperature control is taken over as the set-point value for the flow-rate control.

12.13.7. DE_T – Insensitivity range of the cascaded temperature control

Analogously to the $DEAD$ menu option (see chapter 12.13.5.) this function causes the cascaded temperature controller to respond from a specific control difference only.

The dead zone is entered as an absolute value according to the temperature unit selected in the $UNIT$ menu.

12.13.8. INV – Effective direction between process value and valve position

This function is used to set the effective direction between the process value and the position of the valve (see Figure 56:). Selection of inverted or not inverted control is possible.

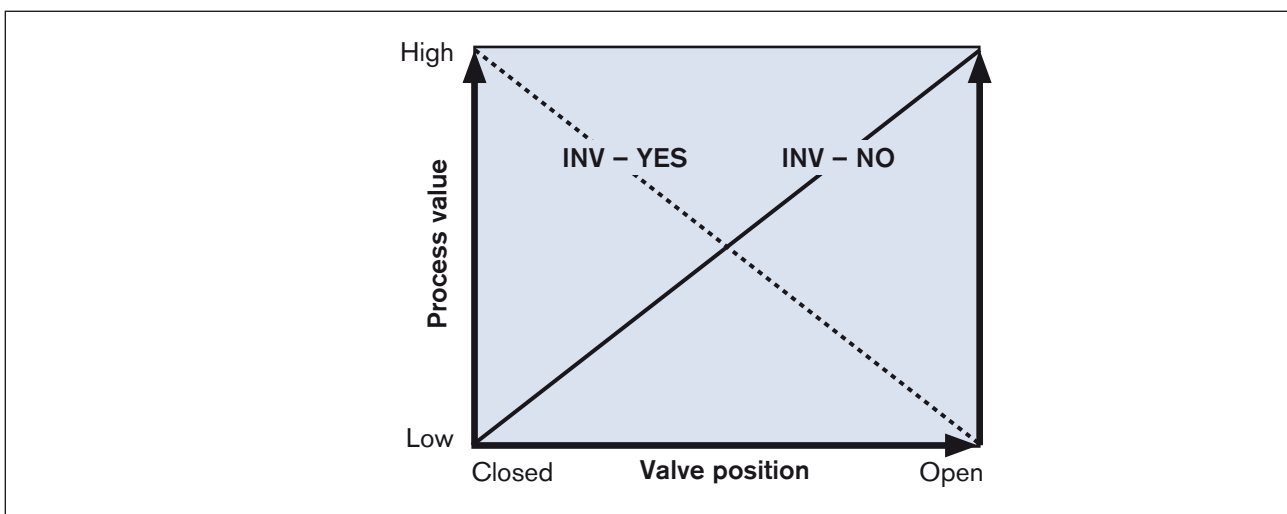

Figure 56: INV ; Effective direction between valve position and process value

| Display <i>INV</i> | Description |
|-----------------------|--|
| NO | Not inverted or direct control (the process value increases with the opening of the valve) |
| YES | Inverted control (the process value decreases with the opening of the valve) |

Figure 57: *Display INV*

12.13.9. ZERO – Zero point shut-off

The zero point shut-off can be activated or deactivated. When the zero point shut-off is activated it is ensured that the valves close securely.

| Display <i>ZERO</i> | Description |
|------------------------|---|
| NO | No zero point shut-off. The control is continuous up to the lower limit value of the value range defined in <i>SETP-EXT</i> (see chapter 12.5.) or up to the lower limit of the range defined in <i>VALV-MIN</i> (see chapter 12.17.). The greater one of the two values is relevant |
| YES | Zero point shut-off is active. The control is continuous until the set-point value < 2% of the upper value range of <i>SETP-EXT</i> has been reached. If the 2% limit is not reached, all valve outputs are disconnected from the voltage supply. When valves are controlled with 0 - 10 V or 4 - 20 mA, the control signal is set to 0 V or 4 mA. |

Figure 58: *Display ZERO*

12.13.10. STRT – Start value for active control

A start value can be defined for continuous actuating elements; this start value is approached immediately by the actuating element when the control is started.

If the working point of the control valve is known, this can be set as start value. The working point of the valve is then controlled very quickly. Depending on the selected actuating element, the following selection options are available:

| Selected actuating element | Value range |
|---|--------------|
| Solenoid control valve (SCV), open/closed valve (<i>2P - T</i> , <i>3P - T</i>) | 0 % - 100 % |
| Control valve with 0 - 10 V control (<i>0 - 10</i>) | 0 V - 10 V |
| Control valve with 4 - 20 mA control (<i>4 - 20</i>) | 4 mA - 20 mA |

Figure 59: *Start value setting*

12.14. B_IN - Configuration of binary input

The binary input allows for starting various controller functions. The feedback from a limit switch (for filling level, pressure, etc.), the feedback from a PLC, etc. may be binary input signals.

What menu options are displayed for the configuration depends on the actuating element set in the *MODE* menu.

Setting in the menu:

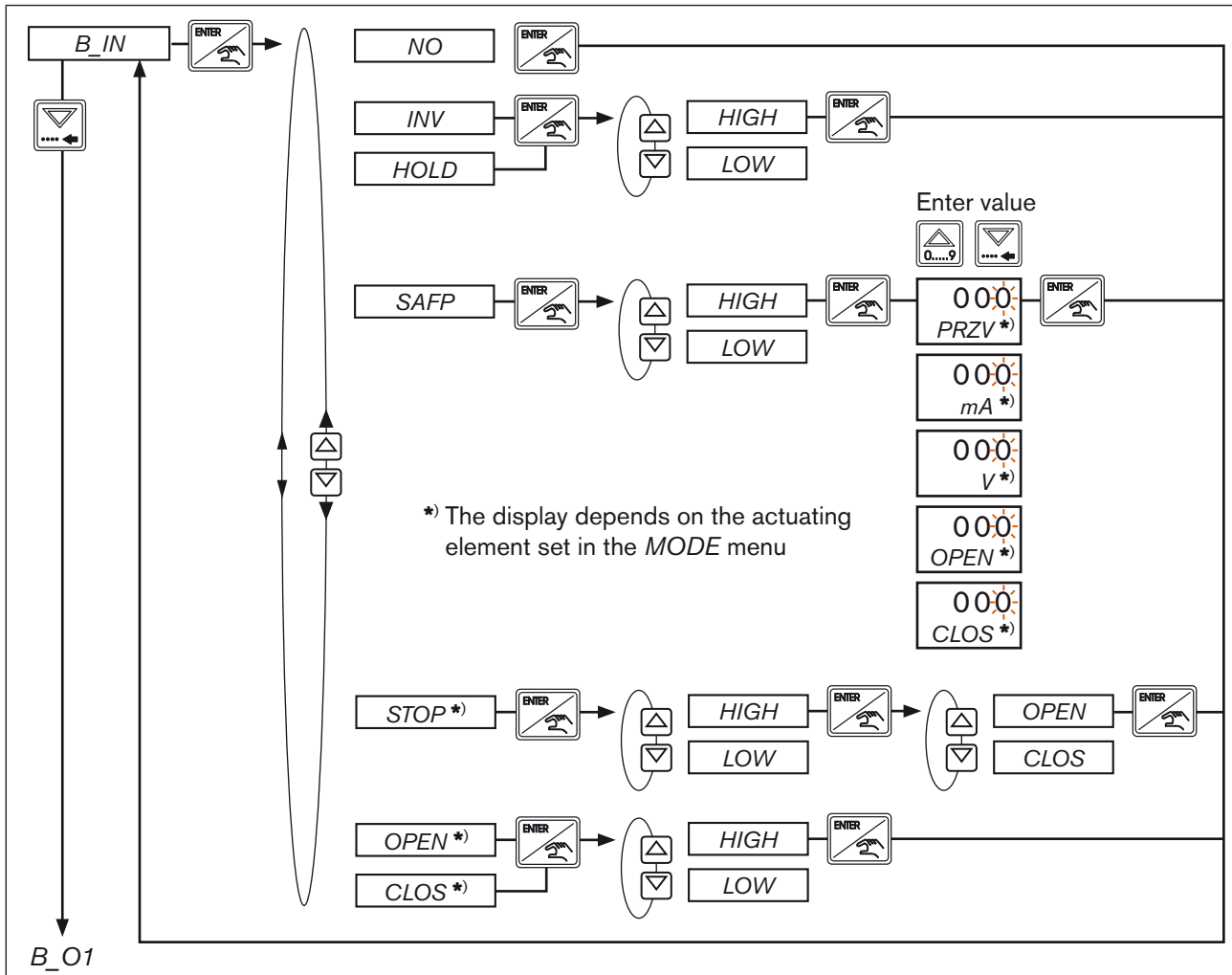

Figure 60: B_IN; Configuration of binary input

| Display | Description |
|---------|--|
| NO | Binary input not active |
| INV | Inverting of the effective direction defined in the <i>PARA</i> menu. By this, the controller can be switched via an external signal from "cooling" to "heating", for example. |
| HOLD | Stopping the controller when binary input is active. Valve remains in current position. If control is active, the "2" is displayed. |

MAN 1000094736 EN Version: G Status: RL (released | freigegeben) printed: 13.01.2011

| Display | Description |
|-------------|--|
| <i>SAFP</i> | Setting of a safety position that is approached when binary input is active. Depending on the actuating element, the following options can be selected: <i>PRZV</i> : Control ratio in [%] for proportional valves <i>mA</i> : Control in [mA] for drives with current input as manipulated variable <i>V</i> : Control in [mA] for drives with voltage as manipulated variable <i>OPEN</i> : Open valve completely <i>CLOS</i> : Close valve completely |
| <i>STOP</i> | Valve movement is stopped (e.g. if the valve has reached the limit stop). The controller remains active and the binary input is automatically deactivated when the limit stop is left. The following functions are available for selection: <i>OPEN</i> : Opening movement is stopped <i>CLOS</i> : Closing movement is stopped These functions are only required when using valves without position feedback in conjunction with limit switches. If, for example, the set-point value has not yet been reached and the limit switch is active, the opening or closing movement is stopped. The <i>STOP</i> menu option is only displayed if, in the <i>MODE</i> menu, <i>PCV</i> , <i>2P – T</i> or <i>3P – T</i> was selected as actuating element. |
| <i>OPEN</i> | Valve is opened. The opening is restricted by the value set in <i>VALV, MAX</i> (see chapter 12.17. <i>VALV - Test function and setting of the control range</i>). The <i>OPEN</i> menu option is only displayed if, in the <i>MODE</i> menu, <i>SCV</i> , <i>4 – 20</i> or <i>0 – 10</i> was selected as actuating element. |
| <i>CLOS</i> | Valve is being closed. The closing is restricted by the value set in <i>VALV, MIN</i> (see chapter 12.17. <i>VALV - Test function and setting of the control range</i>). The <i>CLOS</i> menu option is only displayed if, in the <i>MODE</i> menu, <i>SCV</i> , <i>4 – 20</i> or <i>0 – 10</i> was selected as actuating element. |
| <i>HIGH</i> | Binary input active if $3\text{ V} < B_IN < 30\text{ V}$ |
| <i>LOW</i> | Binary input active if $0\text{ V} < B_IN < 2.7\text{ V}$ |

Table 30: *Display B_IN*

12.15. *B_01* - Configuration of the binary output

In this menu, the binary output for one of the following functions can be configured:

| | |
|-----------------------------------|---|
| <input type="text" value="NO"/> | Binary output not active |
| <input type="text" value="PULS"/> | Pulse output (<i>PULS</i>) Depending on a flow-rate, a pulse signal can be emitted. |
| <input type="text" value="LIMT"/> | Output for limit value monitoring (<i>LIMT</i>). Depending on limit values, alarms or switching contacts can be set for the case that such values are exceeded or not reached. |
| <input type="text" value="2_P"/> | Output for discontinuous 2-state control (<i>2_P</i>). |

Table 31: *B_01; Functions*

12.15.1. PULS - Configuration of the binary output as pulse output

In this menu, it can be defined when, referred to a specific flow-rate volume, a pulse signal is to be emitted.

The measuring units and the volume per pulse can be selected as followed:

| | |
|------|--|
| DM3 | Cubic decimeters (liters) |
| IGAL | British gallon (Imperial) |
| UGAL | American gallon |
| M3 | Cubic meters |
| PU | Flow-rate volume per pulse (number of pulses) related to selected measuring unit |

Table 32: Measuring units for pulse output

Setting aid:

Selection of the number of pulses:

The pulse frequency f_{PU} is calculated according to the equation

$$f_{PU} = \frac{Q \text{ (flow-rate)}}{PU \text{ (number of pulses)}}$$

The pulse frequency may never exceed the frequency of 150 Hz. Select the number of pulses PU so that you obtain a max. frequency of 150 Hz for the maximum flow-rate.
A clock ratio of 50 % is emitted over the entire frequency range.

Setting in the menu:

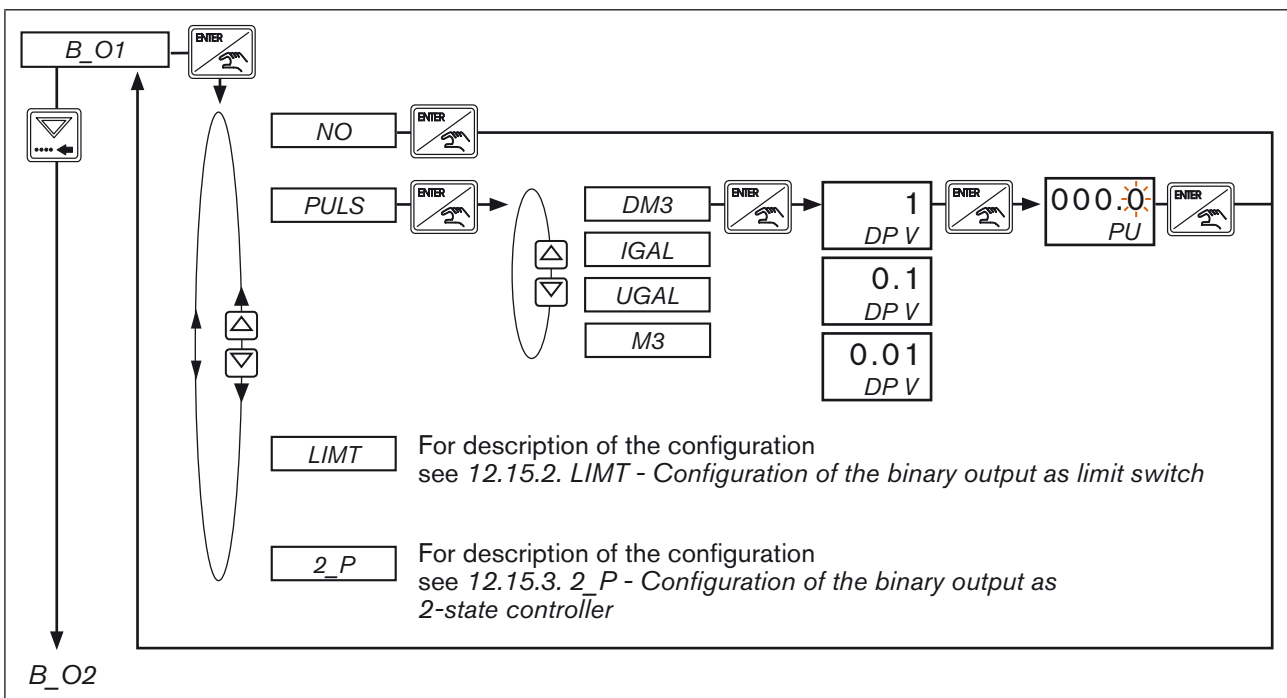

Figure 61: B_O1; Configuration of the binary output as pulse output

MAN 1000094736 EN Version: G Status: RL (released / freigegeben) printed: 13.01.2011

12.15.2. LIMT - Configuration of the binary output as limit switch

This menu can be used to set alarms or switching contacts if specific limit values are exceeded or not reached.

Setting in the menu:

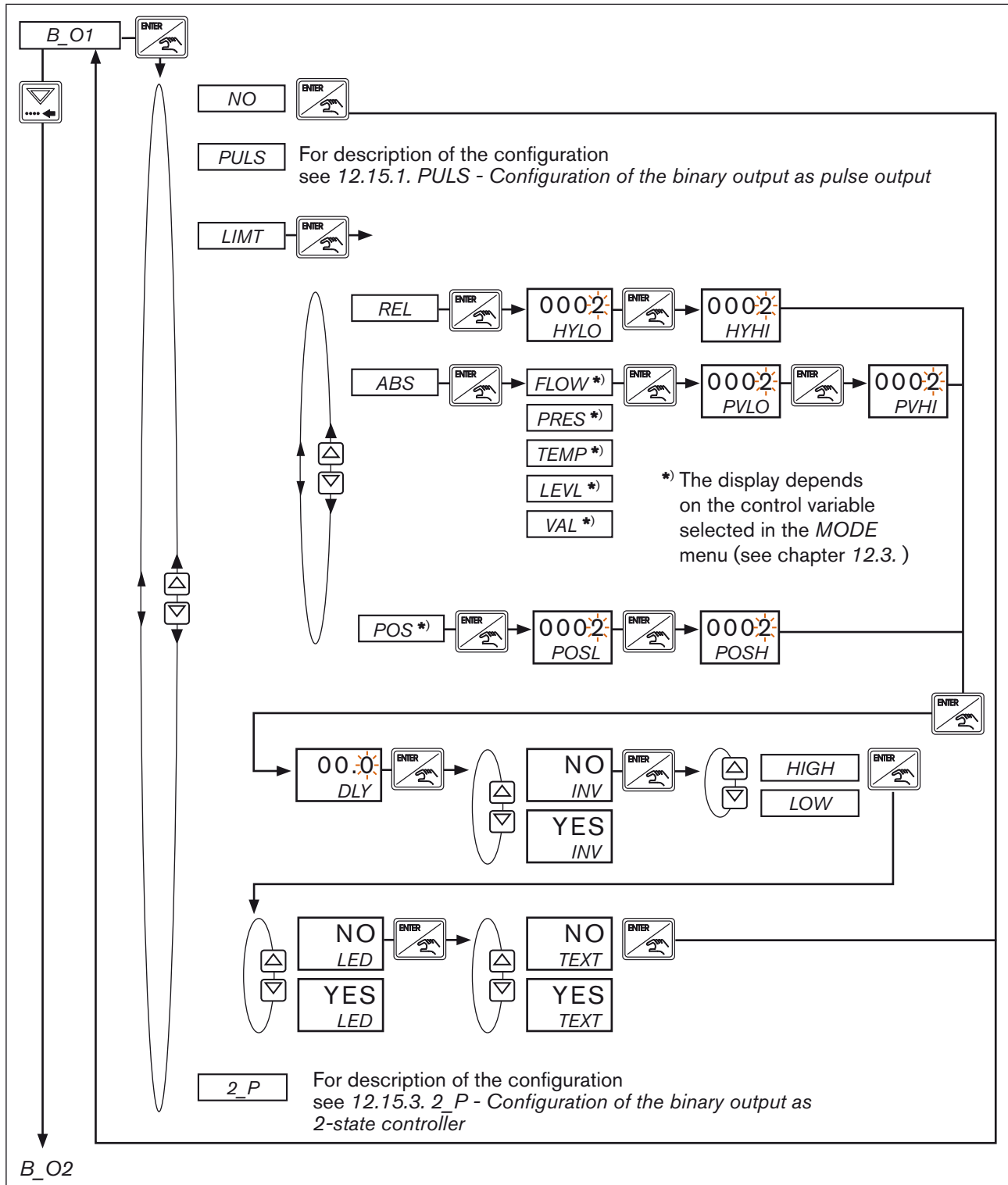

Figure 62: B_O1; Configuration of the binary output as limit switch (LIMT)

| Display | Description |
|--------------|---|
| <i>LIMIT</i> | Selection for the binary output with the function as limit switch. |
| <i>REL</i> | <p>Limit states are monitored relatively to the set-point value (<i>SETP</i>) using a super-imposed switching hysteresis between the limit values (<i>SETP+HYLO</i>) and <i>SETP-HYLO</i>). If the set-point value (<i>SETP</i>) is changed, the monitoring limits are adapted automatically.</p> <p>See Figure 64:</p> <p><i>HYHI</i>: Permissible exceeding of upper set-point value</p> <p><i>HYLO</i>: Permissible dropping below lower set-point value</p> <p>Value range: <i>HYHI, HYLO</i> ≥ 0</p> <p>Measuring unit: absolute, like defined in <i>UNIT</i></p> |
| <i>ABS</i> | <p>Limit values are monitored absolutely to fixed limit values (<i>PVHI</i>) and (<i>PVLO</i>). Depending on the selected control variable and measuring unit following variables can be selected:</p> <p><i>FLOW</i>: Monitoring of flow</p> <p><i>PRES</i>: Monitoring of pressure</p> <p><i>TEMP</i>: Monitoring of temperature</p> <p><i>LEVL</i>: Monitoring of level</p> <p><i>VAL</i>: Monitoring of conductivity, pH-value, concentration or process values without indication of units (<i>UNIT = NU</i>)</p> <p><i>PVHI</i>: Upper switching threshold referred to analog process variable</p> <p><i>PVLO</i>: Lower switching threshold referred to analog process variable</p> <p>Value range <i>PVLO, PVHI</i>: <i>PVHI</i> $>$ <i>PVLO</i></p> <p>Measuring unit: absolute, like defined in <i>UNIT</i></p> |
| <i>POS</i> | <p>Monitoring takes place relatively to the valve position (<i>POS</i>).</p> <p><i>POSL</i>: Lower switching threshold referred to valve position (% , mA or V)</p> <p><i>POSH</i>: Upper switching threshold referred to valve position (% , mA or V)</p> <p>Value range <i>POSL/POSH</i>: <i>POSH</i> $>$ <i>POSL</i></p> |
| <i>DLY</i> | Time in sec for that the deviation must constantly be present. |
| <i>INV</i> | <p>Specify whether the limit switch is to be active inside or outside the monitoring window.</p> <p><i>YES</i>: Binary output is active if the limit values are inside the monitoring window.</p> <p><i>NO</i>: Binary output is active if the limit values are outside the monitoring window.</p> |
| <i>HIGH</i> | Binary output active at voltage of 24 V. |
| <i>LOW</i> | Binary output active at voltage of 0 V. |
| <i>LED</i> | <p><i>YES</i>: LED is on, if binary output is active</p> <p><i>NO</i>: LED is off, if binary output is active</p> |
| <i>TEXT</i> | <p><i>YES</i>: Indication of error message (<i>ERR</i>), if binary output is active</p> <p><i>NO</i>: No indication of error message (<i>ERR</i>), if binary output is active</p> |

Table 33: Display B_O1, LIMIT

Schematic representation of a limit value monitoring referred to fixed process value limits:

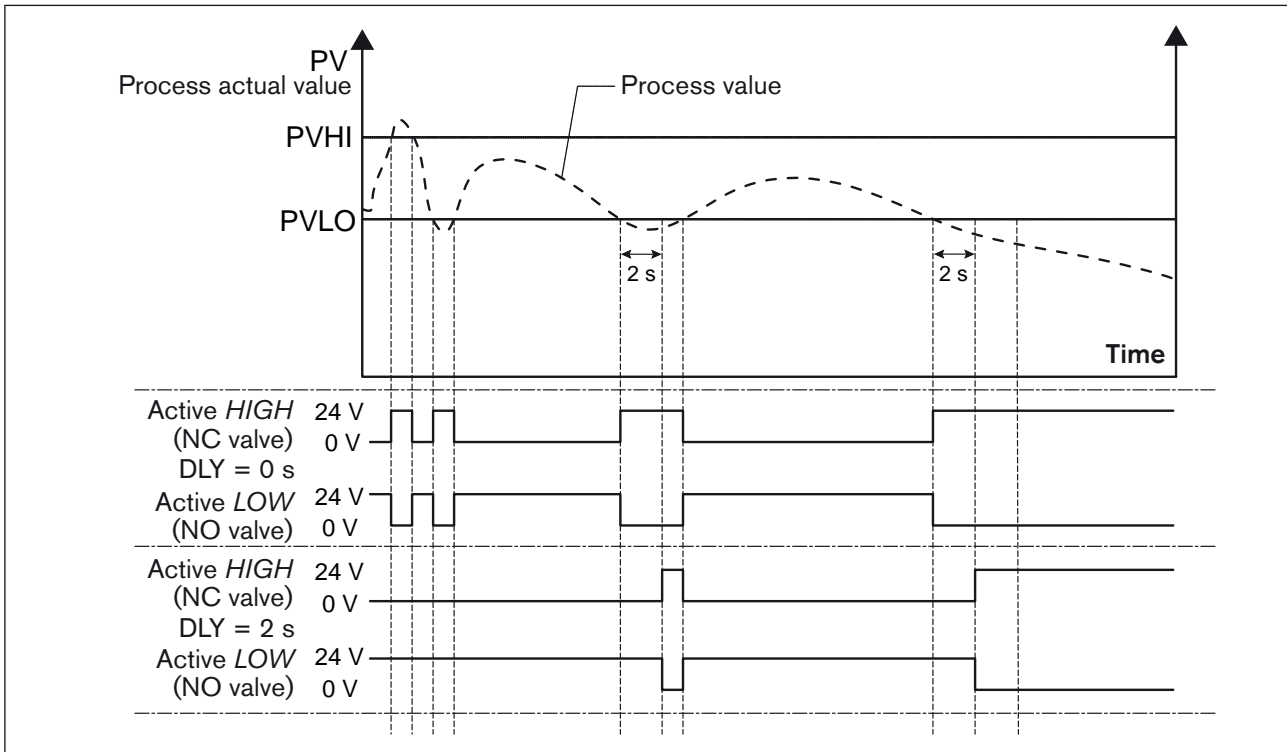

Figure 63: B_O1; LIMT; Limit value monitoring referred to fixed process value limits

Schematic representation of a limit value monitoring relatively to the variable set-point value:

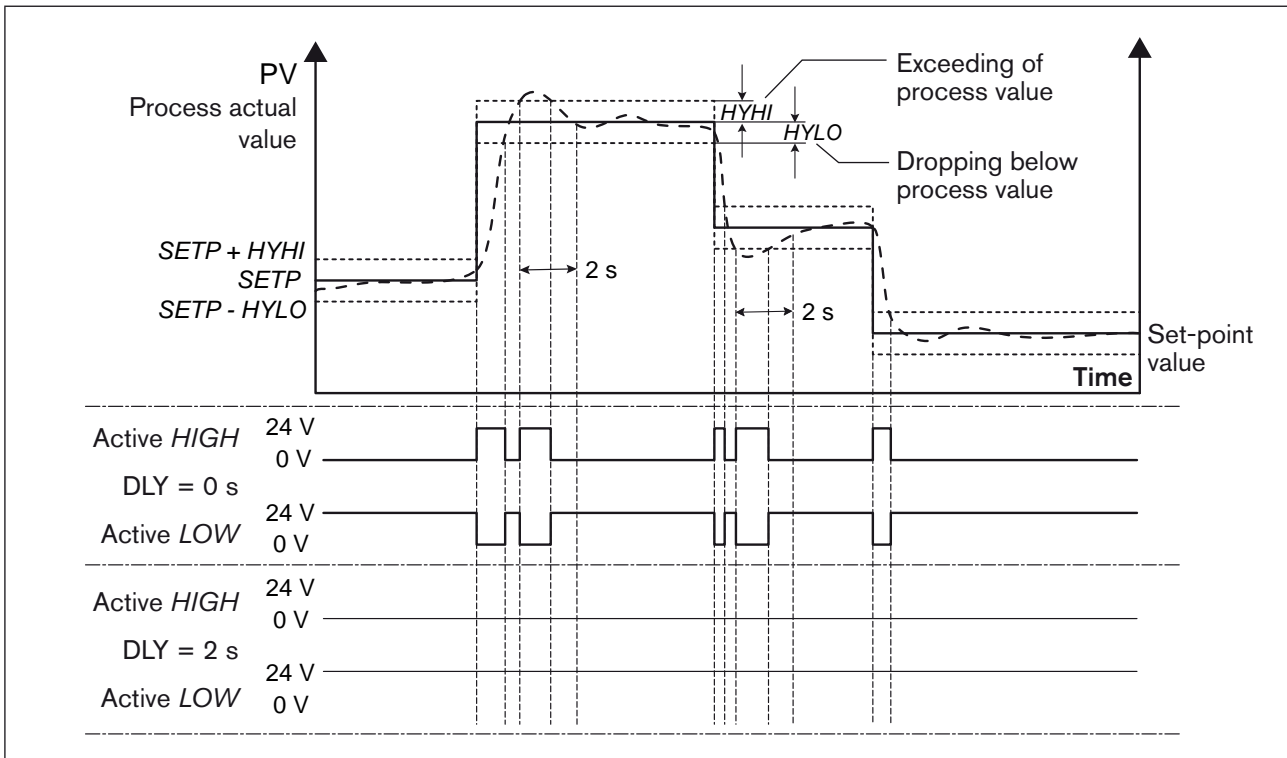
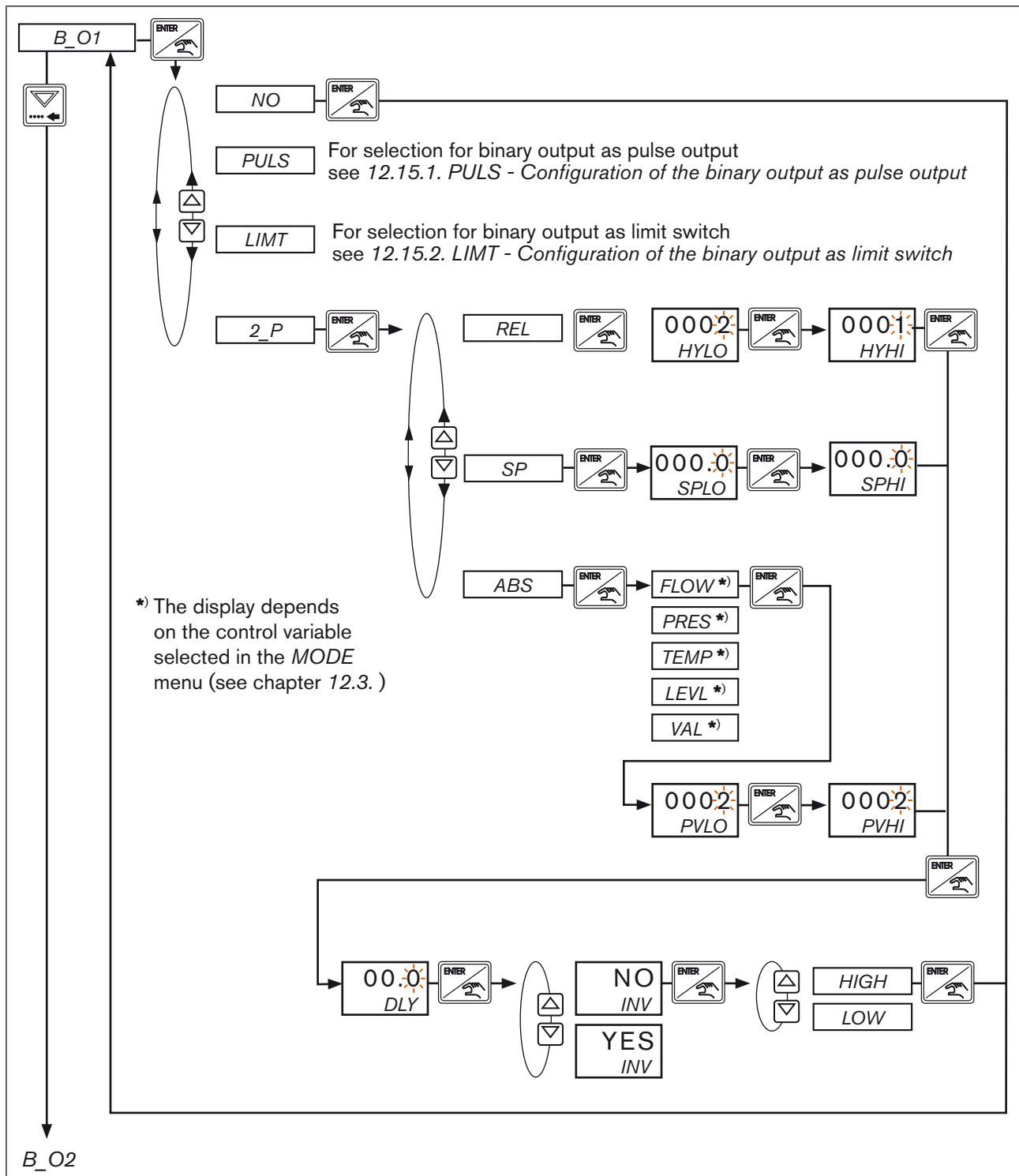

Figure 64: B_O1; LIMT; limit value monitoring relatively to the variable set-point value

12.15.3. 2_P - Configuration of the binary output as 2-state controller

In the discontinuous 2-state control, an open/closed valve is opened or closed depending on two limit values, for example.

Setting in the menu:



MAN 1000094736 EN Version: G Status: RL (released | freigegeben) printed: 13.01.2011

Figure 65: B_O1; Configuration of the binary output as 2-state control (2_P)

| Display | Description |
|-------------|---|
| <i>2_P</i> | Selection for the binary output with the function as 2-state controller. |
| <i>REL</i> | <p>The 2-state control is implemented relatively to the set-point value depending on the deviation between set-point value and actual process value. If the set-point value is changed, the control limits are adapted automatically. See <i>Figure 66: B_O1, 2_P; 2-state control relatively to the set-point value</i></p> <p><i>HYHI</i>: Upper hysteresis <i>HYLO</i>: Lower hysteresis Value range: <i>HYHI, HYLO</i> >= 0 Measuring unit: absolute, like defined in <i>UNIT</i></p> |
| <i>SP</i> | <p>The switching of the outputs is done relatively to the set-point value (<i>SETP</i>) between the limit values (<i>SPHI</i>) and (<i>SPLO</i>). This function can be used e. g. for opening or closing an additional open/closed valve for extending the working range of the control valve.</p> <p><i>SPLO</i>: Lower switching threshold referred to set-point value <i>SPHI</i>: Upper switching threshold referred to set-point value Measuring unit: absolute, like defined in <i>UNIT</i></p> |
| <i>ABS</i> | <p>2-state control between the fixed limit values (<i>PVHI</i>) and (<i>PVLO</i>). Depending on the selected control variable and measuring unit following can be selected:</p> <p><i>FLOW</i>: 2-state control of flow <i>PRES</i>: 2-state control of pressure <i>TEMP</i>: 2-state control of temperature <i>LEVL</i>: 2-state control of level <i>VAL</i>: 2-state control of conductivity, pH-value, concentration or process values without indication of units (<i>UNIT</i> = NU) <i>PVHI</i>: Upper switching threshold referred to analog process value. <i>PVLO</i>: Lower switching threshold referred to analog process value. (<i>PVHI</i> >= <i>PVLO</i>)</p> <p>The 2-state control between the limit values <i>PVHI</i> and <i>PVLO</i> can, for example, be used for the filling level control in a tank.</p> |
| <i>DLY</i> | Time in sec for that the deviation must constantly be present. |
| <i>INV</i> | <p>Effective direction between the process value and the opening of the valve</p> <p><i>YES</i>: Inverted control direction <i>NO</i>: Direct control direction (not inverted)</p> <p>Example: The control is inverted, if the displayed process value decreases when the valve opens.</p> |
| <i>HIGH</i> | Binary output active at voltage of 24 V. |
| <i>LOW</i> | Binary output active at voltage of 0 V. |

Table 34: *Display B_O1, configuration as 2-state controller*

Schematic representation of a 2-state control relatively to the set-point value:

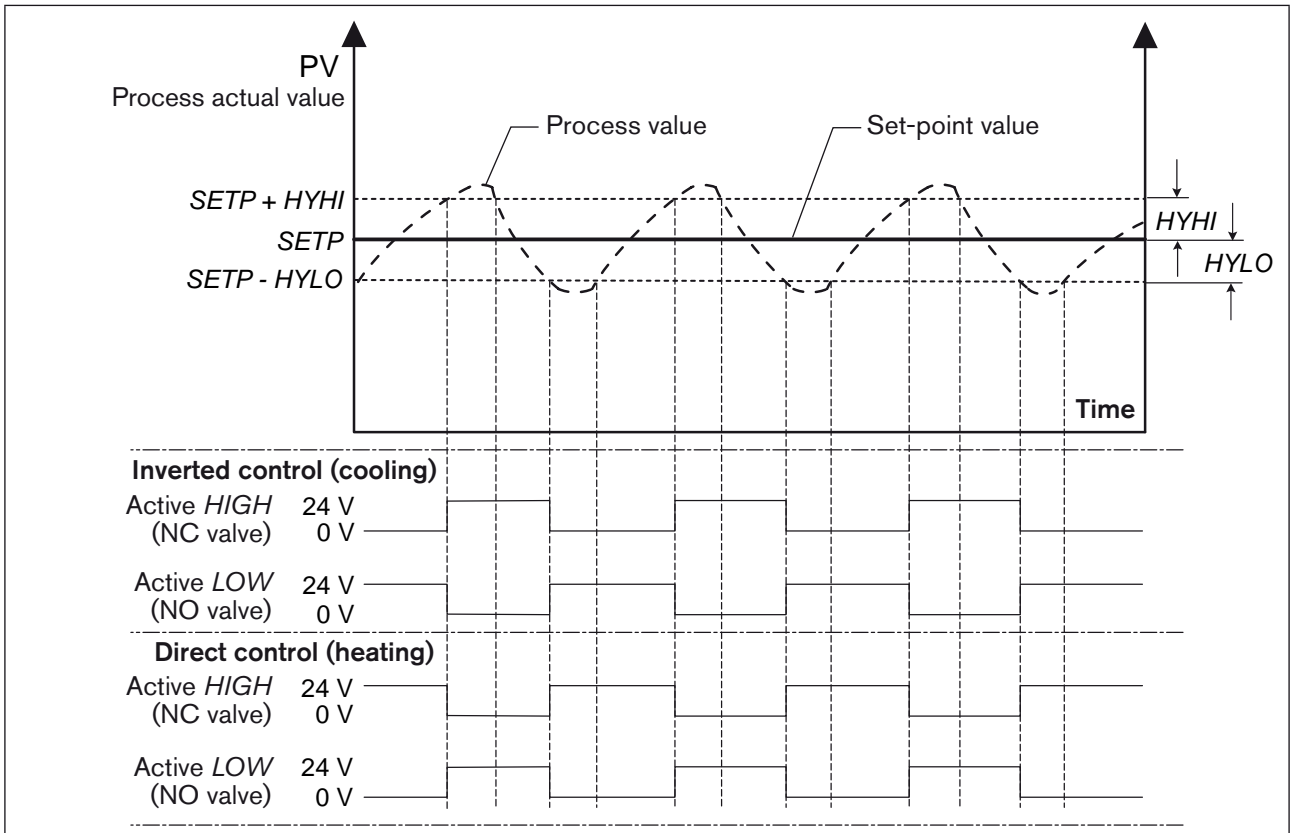

Figure 66: B_O1, 2_P; 2-state control relatively to the set-point value

MAN 1000094736 EN Version: G Status: RL (released / freigegeben) printed: 13.01.2011

12.15.4. Error messages for *B_O1* and *B_O2*

| <i>B_O1</i> | <i>B_O2</i> | Description |
|-------------|-------------|--|
| <i>ERR1</i> | <i>ERR3</i> | <p><i>ERR1</i> is displayed if the process value displayed by the monitoring window is exceeded or not reached relatively to the set-point value ($PV > SETP+HYHI$ or $PV < SETP-HYLO$).</p> <p>The last measurement value is displayed and the red LED is lit.</p> <p>According to the definition made in <i>B_O1</i>, the binary output is set to <i>LOW</i> (0 V) or <i>HIGH</i> (24 V).</p> <p>The controller remains active.</p> <p>RESET: The red LED goes off. The display and the binary output are reset automatically as soon as the process value displayed in the monitoring window is once again within the range of the set-point value.</p> |
| <i>ERR2</i> | <i>ERR4</i> | <p><i>ERR2</i> is displayed if the value displayed by the monitoring window is exceeded or not reached absolutely to the fixed process value limit (<i>PVHI</i>, <i>PVLO</i>).</p> <p>($PV > PVHI$ or $PV < PVLO$).</p> <p>The last measurement value is displayed and the red LED is lit.</p> <p>According to the definition made in <i>B_O1</i>, the binary output is set to <i>LOW</i> (0 V) or <i>HIGH</i> (24 V).</p> <p>The controller remains active.</p> <p>RESET: The red LED goes off. The display and the binary output are reset automatically as soon as the process value displayed in the monitoring window is once again within the process value limit.</p> |

Table 35: *B_O1*; error messages

12.16. *B_O2* - Second binary output

The binary output *B_O2* is only available for the control cabinet model of Type 8611.

The description for binary output *B_O2* is identical to that of binary output *B_O1* (see chapter 12.15.).



As all models of the eCONTROL Type 8611 controller are equipped with the same software, the *B_O2* menu option also exists in the assembly models for wall, rail, valve and fitting assembly, even though binary output *B_O2* is not available.

If *B_O2* is activated, an error message is displayed on the display or by the LED in accordance with the defined limit values.

12.17. VALV - Test function and setting of the control range

In this menu option, the actuating element can be operated manually, for instance in order to

- test how the process variable responds to the change in manipulated variable or
- to define the permissible control range of the actuating element.

It is recommended to carry out the settings under real process conditions if the process allows it.

12.17.1. Control with PI-action structure

(T_N activated, $T_N > 0$), *MODE = SCV, 0 - 10, 4 - 20, 2P - T, 3P - T*

Setting in the menu:

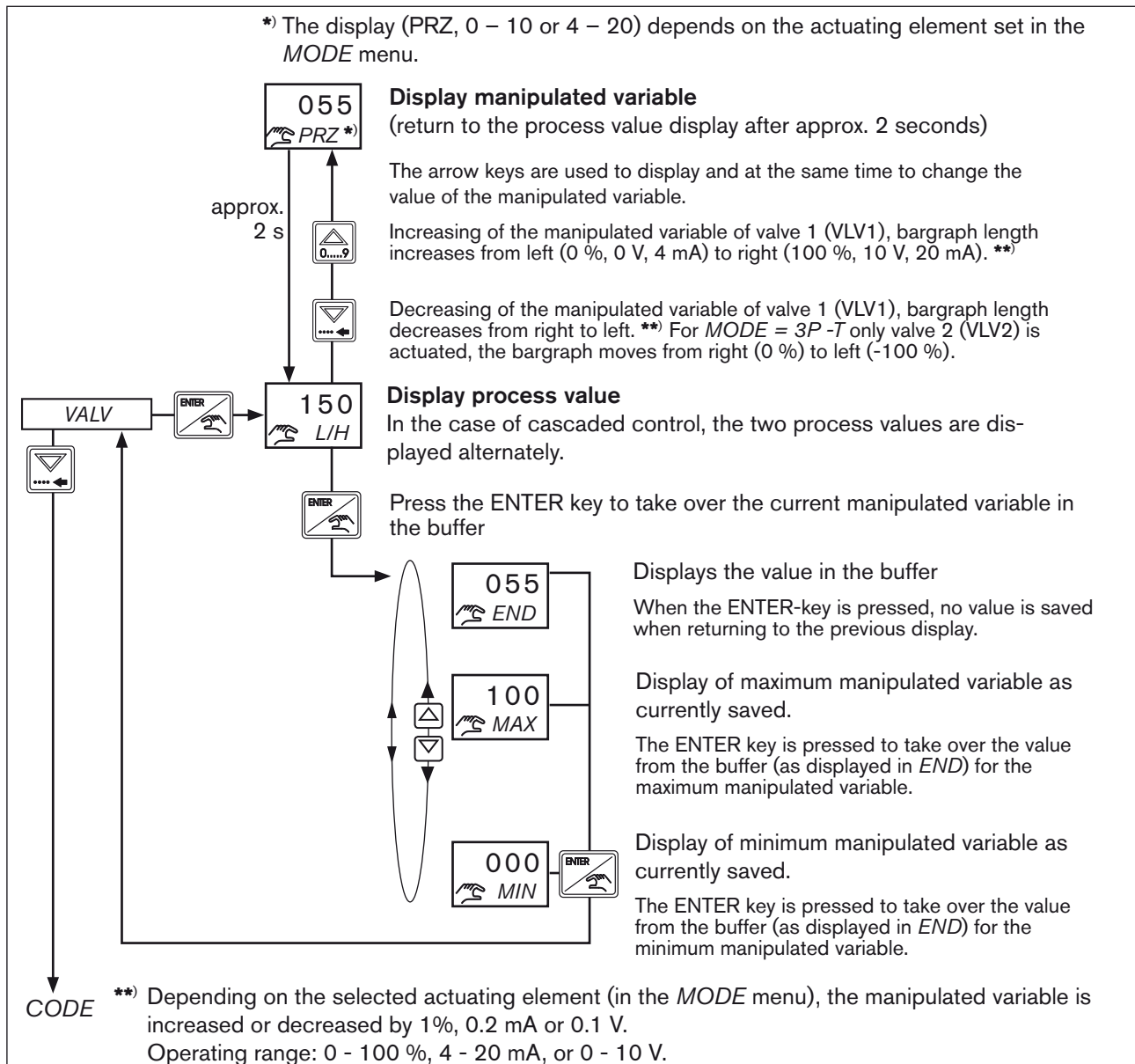

MAN 1000094736 EN Version: G Status: RL (released | freigegeben) printed: 13.01.2011

Table 36: VALV; menu setting for control with PI-action structure (T_N activated, $T_N > 0$)

12.17.2. Control with P-action structure

(T_N deactivated, $T_N = 9999$), $MODE = PCV, 2P - T, 3P - T$

Setting in the menu:

1. Press the ENTER key to display the current process value. In the case of cascaded control, the process value and the flow-rate value are displayed alternately

Press the up arrow key to open the actuating element, and the down arrow key to close the actuating element.

Press the up arrow key to operate the actuating element 1 (VLV1), and the down arrow key to operate the actuating element 2 (VLV2). For $MODE = 2P - T$ only the actuating element 1 (VLV1) can be operated with the arrow up key.

Each time the key is pressed, the actuating element is operated for 40 ms. If the button is pressed continuously the control of the actuating element will be continuously.

Press the ENTER key to take over the displayed process value in the buffer END.

2. Press the arrow keys to switch between the displays for the
 - currently saved maximum value (MAX)
 - currently saved minimum value (MIN)
 in the buffer (END).
3. Press the ENTER key to confirm the selection and
 - if END is selected, no change is made when returning to the previous display.
 - When selecting MIN or MAX the value from the buffer is displayed. It can be stored by pressing the ENTER key once again, or can manually be overwritten using the arrow keys before saving.

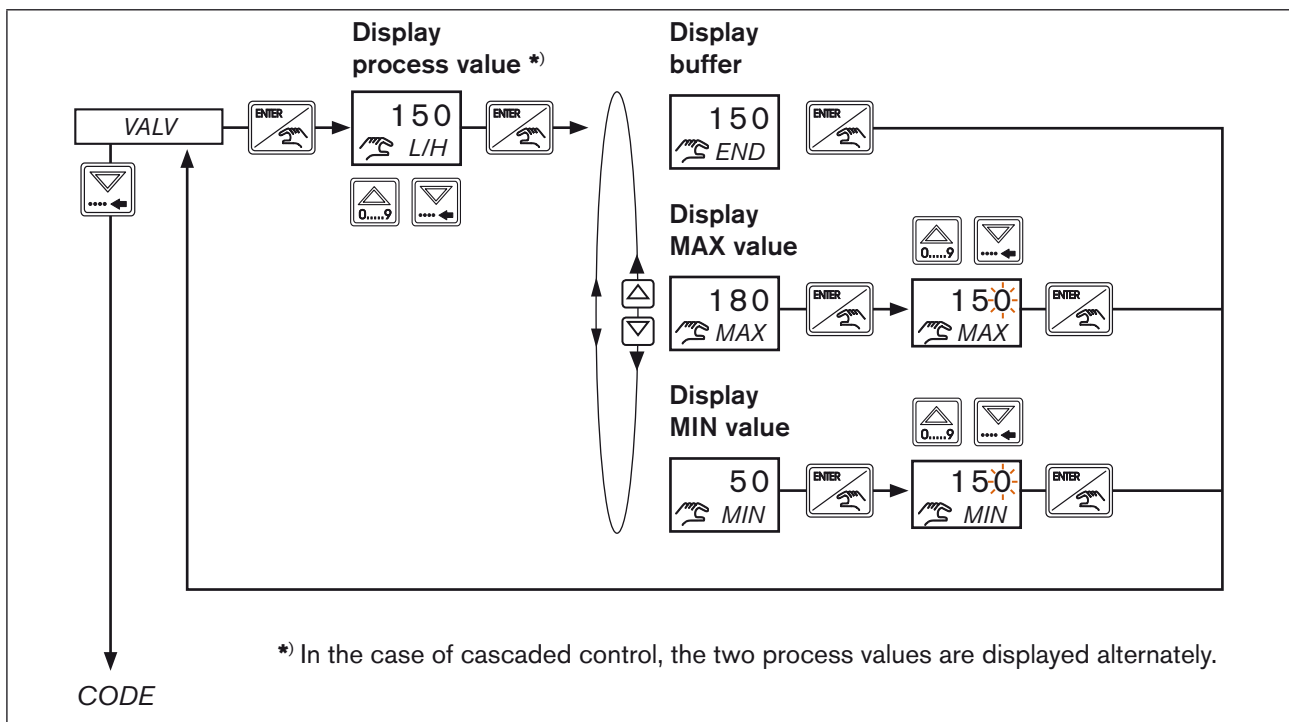

Figure 67: VALV, menu setting for control with P-action structure (T_N deactivated, $T_N = 9999$)

12.18. CODE - Code protection

Access to the configuration level can be protected by a code. Any unauthorized persons are thus denied access and cannot change the parameters.

If the code protection is activated, there is a prompt to input the code prior to each blocked operator action.

The following operator actions are blocked if code protection is activated:

- Changing the controller parameters in operating state MANUAL under the *PARA* menu (see chapter 11.8.)
- Access to the configuration level (see chapter 12.1.)



Factory setting:

Upon delivery from the factory, the display in the *CODE* menu is set to 0000. This means that the code protection is not activated. Switching to the configuration level (see chapter 9.2.1. *Switching between the operating levels and operating states*) is done without query of the code.

Setting the code protection in the menu:

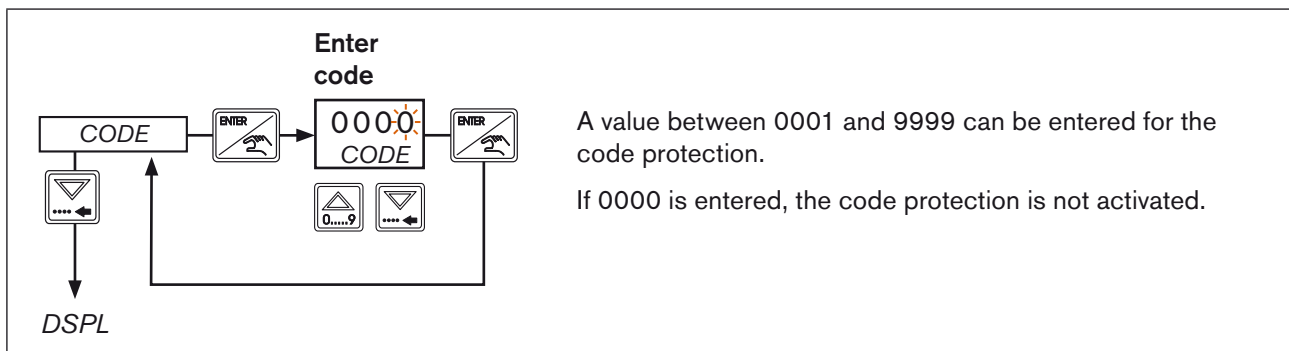

Figure 68: CODE; Setting the code protection

12.18.1. If you have forgotten the code

If you have forgotten the code, access is possible using a master code.

In this case, please contact your the sales office responsible for you. The contact details can be found on our homepage under www.burkert.com → Bürkert → Company → Locations

12.19. DSPL - Setting the display

In this menu, the following settings for the display can be made:

- Activation of the background lighting
- Define what value or what manipulated variable should be displayed after switching on the voltage.

Setting the display in the menu:

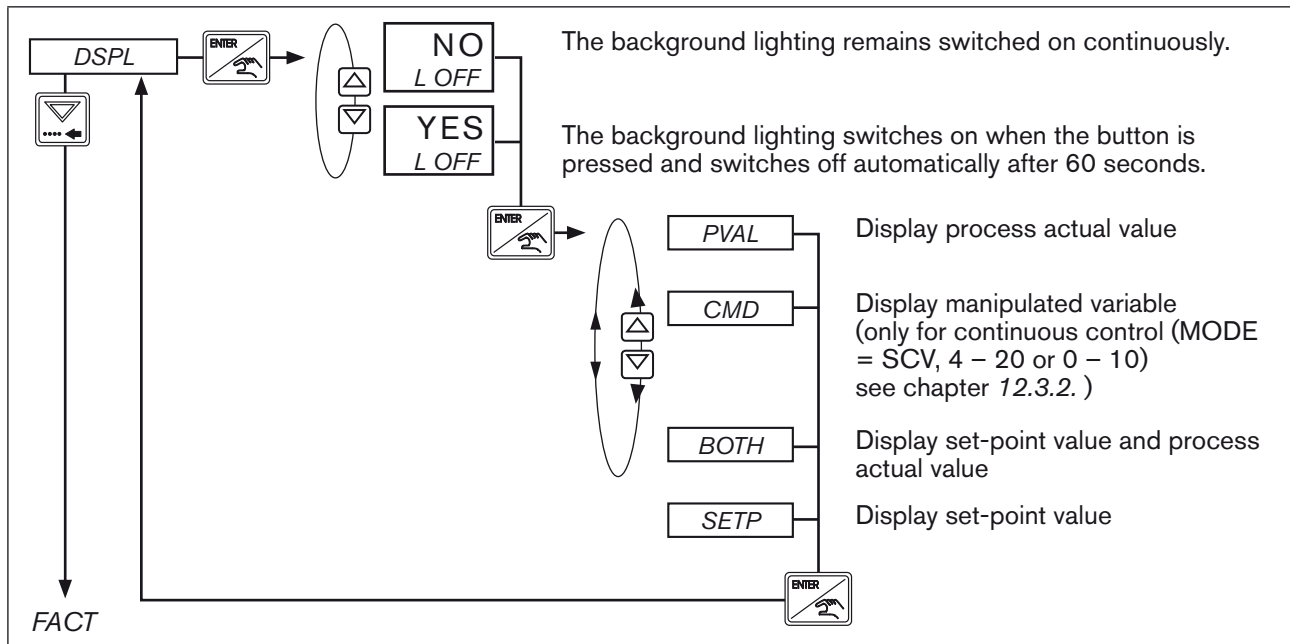

Figure 69: DSPL; Setting the display

| Display | Description |
|---------|--|
| PVAL | Display process actual value. Depending on the unit selected in the <i>UNIT</i> menu (see chapter 12.4.) the corresponding process actual value with unit is displayed. In the case of cascaded control, the temperature and the flow-rate value are displayed alternately. In the case of ratio control, the two flow-rate values are displayed alternately. |
| CMD | Display manipulated variable. Depending on the actuating element selected in the <i>MODE</i> menu (see chapter 12.3.) the following is displayed: <i>PRZV</i> : Display manipulated variable for control of proportional valve in [%] 4 – 20: Display manipulated variable for control of analog actuating element in [mA] 0 – 10: Display manipulated variable for control of analog actuating element in [V] The <i>CMD</i> function is not available for selection for the actuating elements <i>PCV</i> , <i>2P – T</i> and <i>3P – T</i> . |
| BOTH | Set-point value (<i>SETP</i>) and process actual value (<i>PVAL</i>) are shown on one display |
| SETP | Display set-point value. Depending on the control variable selected in the <i>MODE</i> menu (see chapter 12.3.) the following is displayed: <i>SET</i> : Display set-point value for process control <i>RATI</i> : Display set-point value for ratio control |

Table 37: Display DSPL

12.20. FACT - Reset to Factory Settings

In this menu, the controller Type 8611 can be reset to the factory settings it was delivered with.

Setting in the menu:

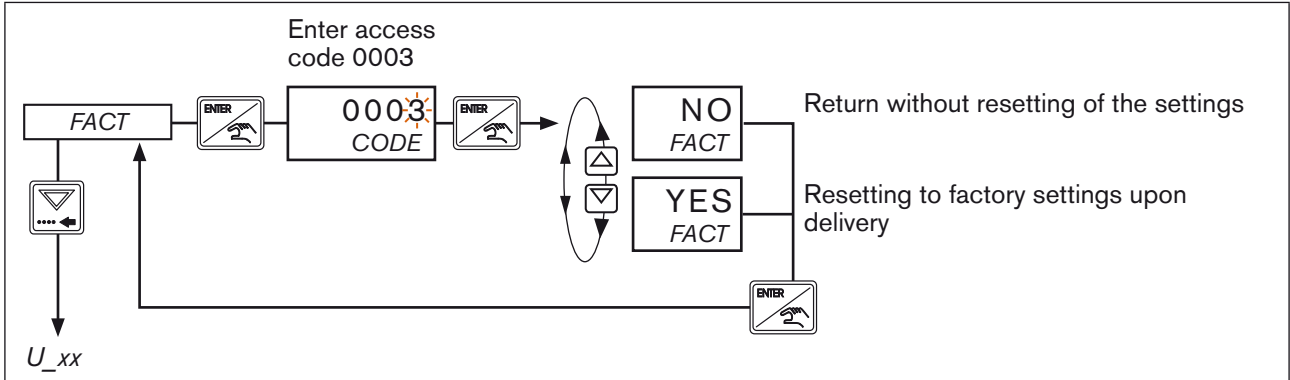

Figure 70: FACT; Reset to Factory Settings

12.21. U_{xx}, B_{xx} - Display of the program version and software version

- In the U_{xx} menu, the program version of the controller Type 8611 is displayed.
- In the B_{xx} menu, the software version of the controller Type 8611 is displayed.

Menu display:

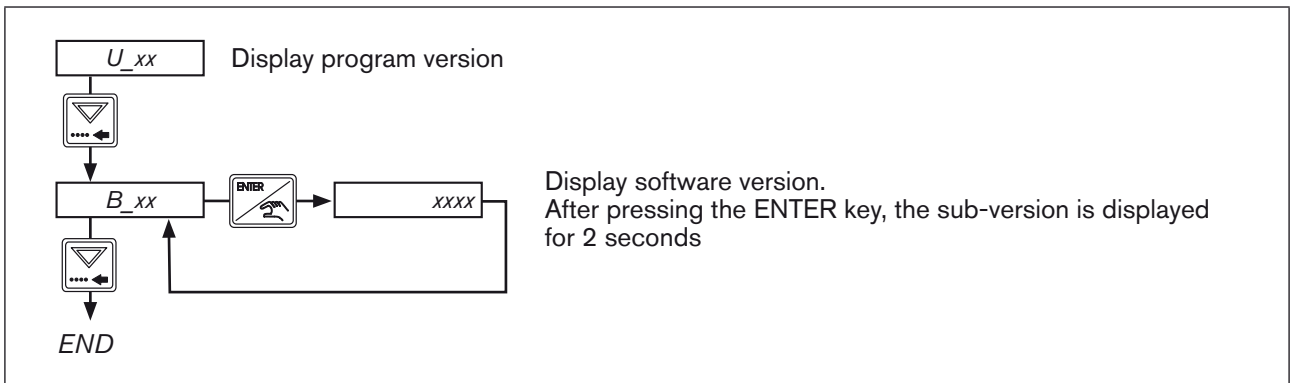

Figure 71: U_{xx}, B_{xx}; Display of the program version and software version

12.22. END - Leaving the configuration level

Press the ENTER key in the END menu option to leave the configuration level. After that, the controller is once again at the process operating level and in the AUTOMATIC operating state (see chapter 9.2.1. *Switching between the operating levels and operating states*).

If the arrow keys are pressed, the controller remains at the configuration level and switches to the next or the previous menu option.

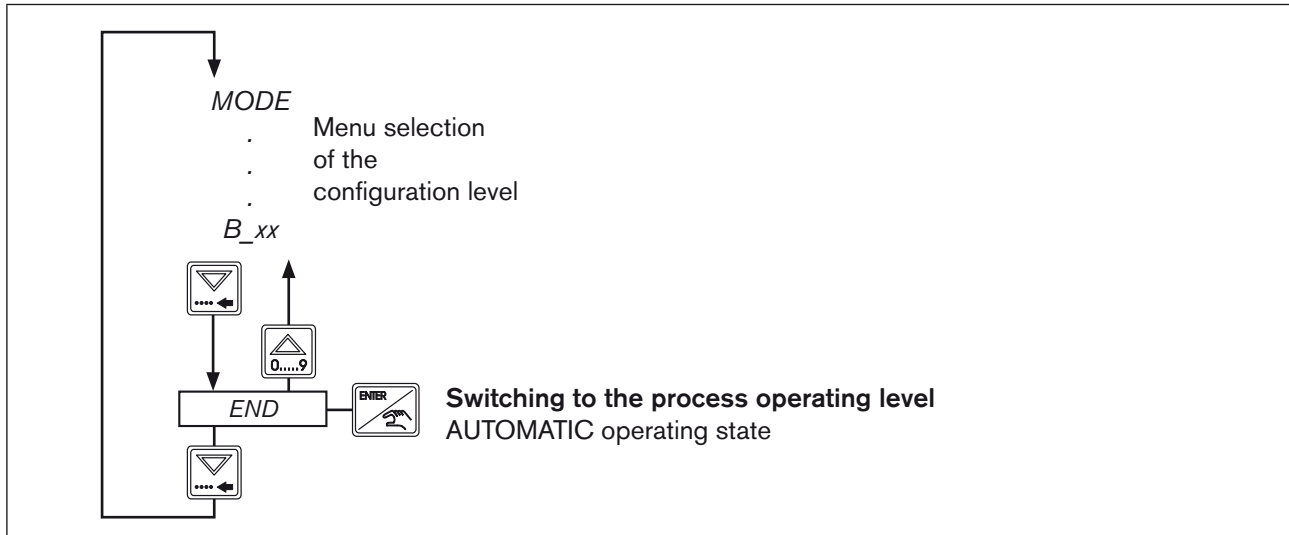

Figure 72: END; Leaving the configuration level

13. OVERVIEW SETTING PARAMETERS

| | | Continuous control | | | Quasi-continuous control | | | Discontinuous control | |
|---|--------------------------|-----------------------------------|--------------------------|---------------|--------------------------|-----------------------------------|-----------------------------|-----------------------|-----------------------|
| Actuating element | | Proportional valve | Linear actuating element | | Process valve | Open/closed valve | Open/closed rotary actuator | Open/closed valve | Open/closed valve |
| Valve parameter (MODE) | Program MODE | SCV | 0-10 | 4-20 | PCV | 2P - T | 3P - T | 2P - T | 3P - T |
| | Control frequency | PWM | [-] | [-] | [-] | [-] | [-] | [-] | [-] |
| | Operating principle | [-] | [-] | [-] | [-] | NC/NO | NC/NO | NC/NO | NC/NO |
| | Minimum control time | [-] | [-] | [-] | TMN1/ TMN2 [ms] | TMN1 [ms] | TMN1/ TMN2 [ms] | TMN1 [ms] | TMN1/ TMN2 [ms] |
| Control structure | | PI oder P (T _N = 9999) | | | P | PI oder P (T _N = 9999) | | P | |
| Control parameter (PARA) | Proportional gain | KP1 [%/PV] | KP1 [%/PV] | | KP1 [%/PV] | KP1 [%/PV] | KP1 / KP2 [%/PV] | KP1 (=9999) | KP1 / KP2 (=9999) |
| | Reset time | TN [s] | TN [s] | TN [s] | [-] | TN [s] | TN [s] | [-] | [-] |
| | Cycle time | [-] | [-] | [-] | TREG [s] | TREG [s] | TREG [s] | [-] | [-] |
| | Dead zone | DEAD [Δ PV] | DEAD [Δ PV] | DEAD [Δ PV] | DEAD [Δ PV] | DEAD [Δ PV] | DEAD [Δ PV] | DEAD [Δ PV] | DEAD [Δ PV] |
| | Control direction | INV (Yes/No) | INV (Yes/No) | INV (Yes/No) | INV (Yes/No) | INV (Yes/No) | INV (Yes/No) | INV (Yes/No) | INV (Yes/No) |
| | Zero point shut-off | ZERO (Yes/No) | ZERO (Yes/No) | ZERO (Yes/No) | ZERO (Yes/No) | ZERO (Yes/No) | ZERO (Yes/No) | ZERO (Yes/No) | ZERO (Yes/No) |
| | Startposition of control | STRT [0-100] | STRT [0-10] | STRT [4-20] | [-] | STRT [0-100] | STRT [0-100] | [-] | [-] |
| Additional control parameters for setting a cascaded control loop (MODE = T + F) | | | | | | | | | |
| Proportional gain | KP_T [%/°K] | KP_T [%/°K] | KP_T [%/°K] | KP_T [%/°K] | KP_T [%/°K] | KP_T [%/°K] | KP_T [%/°K] | KP_T [%/°K] | KP_T [%/°K] |
| Reset time | TN_T [s] | TN_T [s] | TN_T [s] | TN_T [s] | TN_T [s] | TN_T [s] | TN_T [s] | TN_T [s] | TN_T [s] |
| Dead zone | DEAD [Δ °K] | DEAD [Δ °K] | DEAD [Δ °K] | DEAD [Δ °K] | DEAD [Δ °K] | DEAD [Δ °K] | DEAD [Δ °K] | DEAD [Δ °K] | DEAD [Δ °K] |

Table 38: Overview setting parameters

MAN 1000094736 EN Version: G Status: RL (released / freigegeben) printed: 13.01.2011

14. MAINTENANCE, TROUBLESHOOTING

The process controller Type 8611 is maintenance-free when operated according to the instructions in this manual.

14.1. Malfunctions

The table below contains the possible error messages with cause and remedial action.

| Error | Display / action | Cause | Remedial action |
|-------------|--|---|--|
| <i>ERR1</i> | <i>ERR1</i> is displayed and red LED is lit. The process actual value is still displayed. Binary output B_O1 is activated. The control remains active. | The process value displayed by the monitoring window is exceeded or not reached relatively to the set-point value (see menu function B_O1 / LIMT / REL, chapter 12.15.). | For description see chapter 12.15.4. <i>Error messages for B_O1 and B_O2</i> |
| <i>ERR2</i> | <i>ERR2</i> is displayed and red LED is lit. The process actual value is still displayed. Binary output B_O1 is activated. The control remains active. | The process value displayed by the monitoring window is exceeded or not reached absolutely to the fixed process value limit (see menu function B_O1 / LIMT / ABS, chapter 12.15.). | |
| <i>ERR3</i> | <i>ERR3</i> is displayed and red LED is lit. The process actual value is still displayed. Binary output B_O2 is activated. The control remains active. | The process value displayed by the monitoring window is exceeded or not reached relatively to the set-point value (see menu function B_O2 / LIMT / REL, chapter 12.16.). | For description see chapter 12.15.4. <i>Error messages for B_O1 and B_O2</i> |
| <i>ERR4</i> | <i>ERR4</i> is displayed and red LED is lit. The process actual value is still displayed. Binary output B_O2 is activated. The control remains active. | The process value displayed by the monitoring window is exceeded or not reached absolutely to the fixed process value limit (see menu function B_O2 / LIMT / ABS, chapter 12.16.). | |
| <i>ERR5</i> | Display <i>ERR5</i> control is deactivated and valve closes. | Sensor input signal of process actual value < 2 mA. | Check sensor or cables. Acknowledge with ENTER key. |
| <i>ERR6</i> | Display <i>ERR6</i> control is deactivated and valve closes. | Set-point value input signal < 2 mA. | Check sensor or cables. Acknowledge with ENTER key. |
| <i>ERR7</i> | Display <i>ERR7</i> control is deactivated and valve closes. | No temperature sensor (PT100) connected. | Check Pt 100 resistance thermometer. Acknowledge with ENTER key. |

Table 39: Error messages

15. PACKAGING AND TRANSPORT

NOTE!

Transport damages!

Inadequately protected equipment may be damaged during transport.

- During transportation protect the device against moisture and dirt in shock-resistant packaging.
- Do not allow the temperature to exceed or drop below the permitted storage temperature.

16. STORAGE

NOTE!

Incorrect storage may damage the device.

- Store the device in a dry and dust-free location!
- Storage temperature: 0 – +70 °C.

17. DISPOSAL

→ Dispose of the device and packaging in an environmentally friendly manner.

NOTE!

Damage to the environment caused by device components contaminated with media.

- Observe applicable disposal regulations and environmental regulations.



Observe national waste disposal regulations.

