

FINE CONTROLS (UK) LTD



Fine Controls have been supplying process controls & instrumentation equipment since 1994, & now serves an ever expanding customer base, both in the UK & globally.

We offer a full range of valve & instrumentation products & services, with our product range representing leading technologies & brands:

Flow: Flow Meters & Transmitters, Flow Switches, Flow Control Valves & Batch Control Systems

Temperature: Temperature Probes & Thermowells, Temperature transmitters, Temperature Regulators & Temperature Displays

Level: Level Transmitters & Switches

Pressure: Pressure Gauges & Transmitters, Precision & High Pressure Regulators & I-P Converters, Volume boosters.

Precision Pneumatics: Pressure Regulators, I-P Converters, Volume Boosters, Vacuum Regulators

Valves: Solenoid & Pneumatic Valves, Control Valves & Positioners, Actuated Ball, Globe or Diaphragm Valves & Isolation Valves

Services: Repair, Calibration, Panel Build, System Design & Commissioning

A rotork® Brand
FAIRCHILD



bürkert



SIEMENS



alcon
SOLENOID VALVES

A rotork® Brand



MIDLAND-ACS
A rotork® Brand



Honeywell



Bourdon
Baumer Group



SOLDO
CONTROLS

A rotork® Brand



Fine Controls (UK) LTD, Bassendale Road, Croft Business Park,
Bromborough, Wirral, CH62 3QL UK
Tel: 0151 343 9966
Email: sales@finecontrols.com



Mechanical flow switch for On/Off control

- Economic integration in pipe systems without any additional piping
- Magnetic measuring principle
- Mechanical adjustment of setpoint

Type 8010 can be combined with...



Valve



Alarm

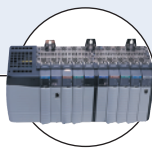

PLC

The INLINE flow sensor/switch Type 8010 is specially designed for use in pure and water resembling fluids, free from air bubbles and magnetizable particles, to monitor minimum/maximum values of flow.

The sensor/switch is made up of a fitting (Type S010) and an electronic module (Type SE10), quickly and easily connected together by a Quarter-Turn.

This device indicates the presence of a flow in the pipe by switching the Reed contact contained in the electronic module. The switching points Min./Max. for rising and falling velocities can be set with a screw within a defined range.

The SE10 electronic module is available in two versions:

- Normally open (NO): The flow switches on the contact.
- Normally closed (NC): The flow switches off the contact.

These S010 fittings are available in two versions:

- with a short blade «Range1» fitted for the fittings DN15 to 40.
- with a long blade „Range2» fitted for the fittings DN32 to 50.

General data

Compatibility	With fittings S010 INLINE (see ordering chart)
Sensor element	Blade with magnet, Reed contact
Materials	
Housing, cover	PC, +20% glass fibre reinforced
Setting screw	Plated brass
Cable plug	PA
Materials wetted parts	
Fitting, sensor holder	Brass (CuZn39Pb2), stainless steel (316L - 1.4435), PVC, PP, PVDF
Blade	PVDF
Axis / Seal	Stainless steel (316L) / FKM (EPDM on request)
Electrical connection	Cable plug: EN 175301-803 (provided)
Connection cable	0.14 up to 0.5 mm ² cross section; max. 100 m length

Complete device data (fitting + electronic module)

Pipe diameter	DN 15 to 50
Switching range	4.7 up to 75.4 l/min (see selection table - on page 3)
Flow velocity max.	10 m/s
Medium temperature with fitting in	
PVC	0 up to 50°C (32 to 122°F)
PP, PVDF, brass, stainless steel	0 up to 55°C (32 to 131°F)
Fluid pressure max.	PN10 (with plastic fitting) - PN16 (with metal fitting) see pressure/temperature chart, next page
Viscosity / Solid particles rate	100 cSt. max. / max. 1% (particle size max.: 0.5 mm)

Electrical data	
Power supply	Without
Outputs	
Reed Contact	Potential free, forme A, switch off or switch on
Switching voltage	150 V DC/250 V AC max.
Switching Current	0.8 A max.
Switching power	50 W max., 50 VA
Carrying current	2.5 A

Environment	
Ambient temperature	0 up to +55°C (32 to 131°F) (operating and storage)
Relative humidity	≤ 80%, without condensation

Standards, directives and approvals	
Protection class	IP65 with connector plugged-in and tightened
Standards, directives	
Pressure	Complying with article 3 of §3 from 97/23/CE directive.*
Vibration	EN 60068-2-6
Shock	EN 60068-2-27

* For the 97/23/CE pressure directive, the device can only be used under following conditions (depend on max. pressure, pipe diameter and fluid).

Type of fluid	Conditions
Fluid group 1, §1.3.a	DN25 only
Fluid group 2, §1.3.a	PN*DN ≤ 1000
Fluid group 1, §1.3.b	PN*DN ≤ 2000
Fluid group 2, §1.3.b	DN ≤ 200

Pressure / temperature chart

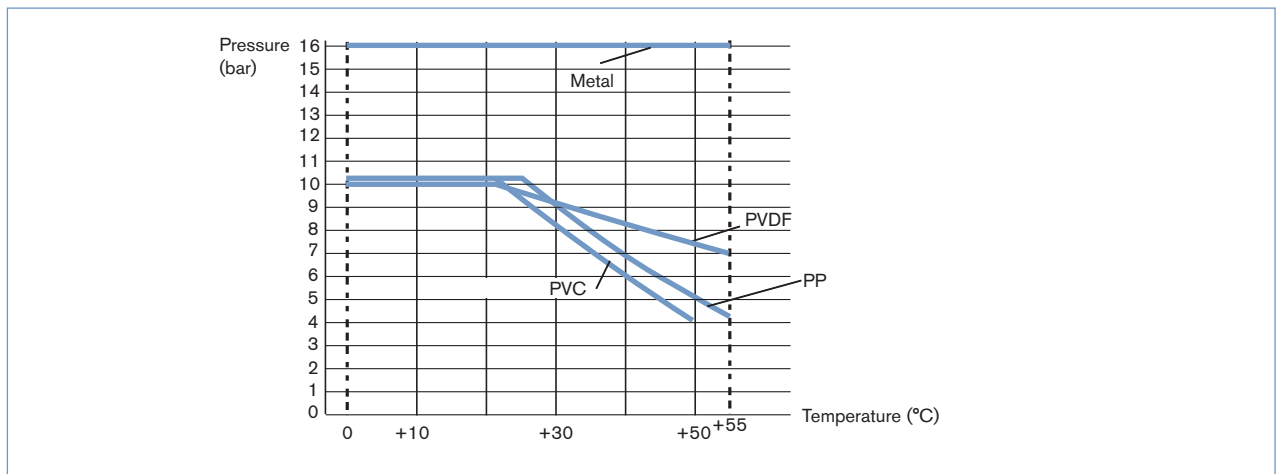

Design, inner materials and principle of operation



The S010 INLINE fitting is made up of a blade with a magnet.

The SE10 module contains a rocker arm with a magnet on each end. When liquid flows through the pipe, the blade rotates and, by magnetic adherence, actuates the rocker arm.

With this rotation, the upper magnet switches the Reed contact opening or closing the circuit. The switching points can be set with a screw within a defined range

No.	Description	Materials
1	Sensor holder	Brass, stainless steel, PVC, PP or PVDF
2	Blade	PVDF
3	Axis	Stainless steel
4	O-Ring	FKM or EPDM

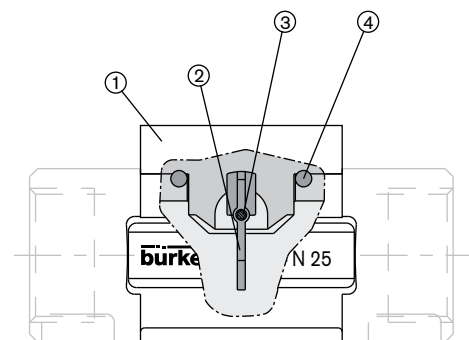

Switching threshold and fitting DN selection chart

The type of blade (Range 1 or 2) and the fitting DN define the flow range on which the switching thresholds can be adjusted. The table below shows the switching end values depending on the selected model of type 8010

Range	Fitting DN	Fluid velocity (Water) [m/s]			Flow rate			
		min.	max.	Variation way	l/min		m³/h	
					min.	max.	min.	max.
1	15	0.65	0.90	increasing	6.9	9.5	0.41	0.57
		0.60	0.80	decreasing	6.4	8.5	0.38	0.51
	20	0.35	0.55	increasing	6.6	10.4	0.40	0.62
		0.25	0.45	decreasing	4.7	8.5	0.28	0.51
	25	0.40	0.60	increasing	11.8	17.7	0.71	1.06
		0.30	0.50	decreasing	8.8	14.7	0.53	0.88
	32	0.65	0.90	increasing	31.4	43.4	1.88	2.61
		0.55	0.70	decreasing	26.5	33.8	1.59	2.03
	40	0.75	1.00	increasing	56.5	75.4	3.39	4.52
		0.60	0.90	decreasing	45.2	67.9	2.71	4.07
2	32	0.18	0.28	increasing	8.5	13.5	0.51	0.81
		0.15	0.22	decreasing	7.0	10.5	0.42	0.63
	40	0.25	0.45	increasing	18.8	33.9	1.13	2.04
		0.20	0.35	decreasing	15.1	26.4	0.90	1.58
	50	0.49	0.59	increasing	58.0	70.0	3.48	4.20
		0.36	0.51	decreasing	42.0	60.0	2.52	3.60

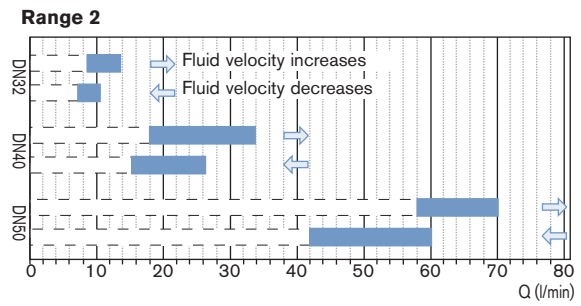
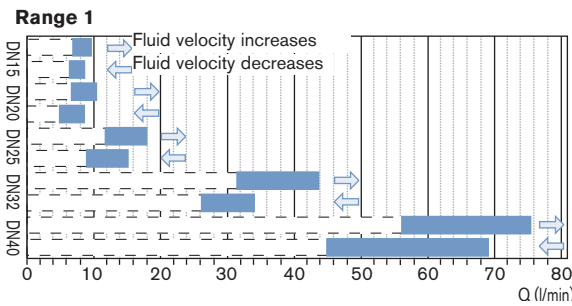

Attention!

The fitting with nominal diameters of 32 and 40 mm are designed for two different switching range (1 and 2) in relation with flow velocity and equivalent flow values. For all other sizes, there is only one switching range (1 or 2).

Dimensions [mm]

Electronic module SE10

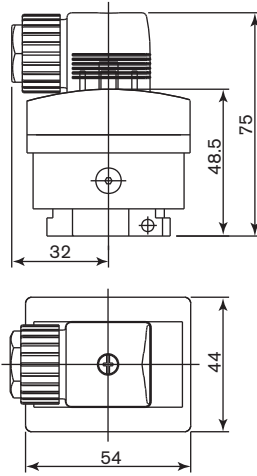

High of Electronic SE10 + Fitting S010

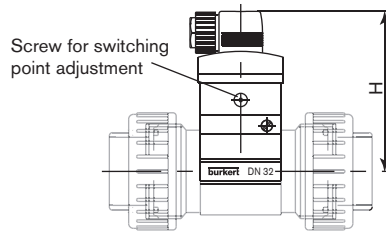

DN	H
15	100
20	97
25	97
32	101
40	105
50	111

True union connection - (solvent or fusion spigot)

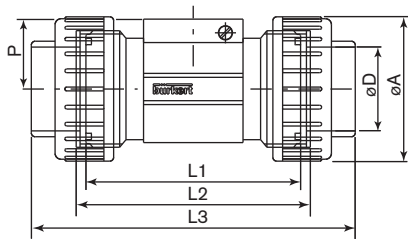

Spigot connection - (solvent or fusion spigot)

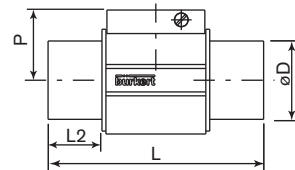

DN	P	True union connection in Plastic						Spigot connection in PVC				Spigot connection in PP or PVDF				
		L1	L2	L3	ANSI*	JIS*	øD	L	ø D	L2	L	ø D	L2			
				DIN	ANSI*	JIS*	DIN	ANSI*	JIS*	øA		ø D	L2	L	ø D	L2
15	34.5	90	96	128	130.0	129.0	20	21.3	18.4	43	90	20	16.5	85	20	14
20	32.0	100	106	144	145.6	145.0	25	26.7	26.45	53	100	25	20.0	92	25	16
25	32.2	110	116	160	161.4	161.0	32	33.4	32.55	60	110	32	23.0	95	32	18
32	35.8	110	116	168	170.0	169.0	40	42.2	38.60	44	110	40	27.5	100	40	20
40	39.6	120	127	188	190.2	190.0	50	48.3	48.70	83	120	50	30.0	106	50	23
50	45.7	130	136	212	213.6	213.0	63	60.3	60.80	103	130	63	37.0	110	63	27

* only for PVC

Dimensions [mm]

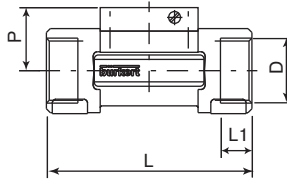
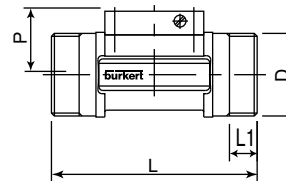
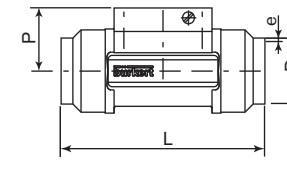
Internal thread connection					External thread connection			Weld ends connection		
										
DN	P	Internal thread connection in stainless steel or brass			External thread connection in stainless steel			Weld ends connection in stainless steel		
		L	L1	D	L	L1	D	L	ø D	e
15	34.5	85	16.0 17.0 15.0	G 1/2 NPT 1/2 Rc 1/2	84	11.5	G 3/4	84	21.3	1.6
20	32.0	95	17.0 18.3 16.3	G 3/4 NPT 3/4 Rc 3/4	94	13.5	G 1	94	26.9	1.6
25	32.2	105	23.5 18.0 18.0	G 1 NPT 1 Rc 1	104	14.0	G 1 1/4	104	33.7	2.0
32	35.8	120	23.5 21.0 21.0	G 1 1/4 NPT 1 1/4 Rc 1 1/4	119	18.0	G 1 1/2	119	42.4	2.0
40	39.6	130	23.5 20.0 19.0	G 1 1/2 NPT 1 1/2 Rc 1 1/2	129	19.0	M55 x 2	129	48.3	2.0
50	45.7	150	27.5 24.0 24.0	G 2 NPT 2 Rc 2	149	20.0	M64 x 2	149	60.3	2.6

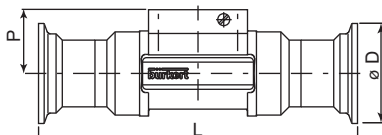
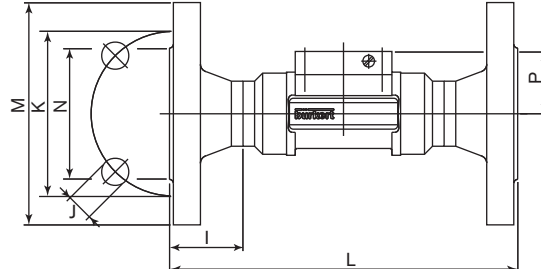
Clamp connection				Flange connection						
										
DN	P	Clamp connection - ISO4200 in stainless steel		Flange connection in stainless steel						
		L	ø D	Norm	L	I	J	M	K	N
15	34.5	130	34.0	DIN ANSI JIS	130 130 152	23,5	4x14.0 4x15.8 4x15.0	95.0 89.0 95.0	65.0 60.3 70.0	45.0 34.9 51.0
20	32.0	150	50.5	DIN ANSI JIS	150 150 178	28,5	4x14.0 4x15.8 4x15.0	105.0 99.0 100.0	75.0 69.8 75.0	58.0 42.9 56.0
25	32.2	160	50.5	DIN ANSI JIS	160 160 216	28,5	4x14.0 4x15.8 4x19.0	115.0 108.0 125.0	85.0 79.4 90.0	68.0 50.8 67.0
32	35.8	180	50.5	DIN ANSI JIS	180 180 229	31,0	4x18.0 4x15.8 4x19.0	140.0 117.0 135.0	100.0 88.9 100.0	78.0 63.5 76.0
40	39.6	200	64.0	DIN ANSI JIS	200 200 241	36,0	4x18.0 4x15.8 4x19.0	150.0 127.0 140.0	110.0 98.4 105.0	88.0 73.0 81.0
50	45.7	230	77.5	DIN ANSI JIS	230 230 267	41,0	4x18.0 4x19.0 4x19.0	165.0 152.0 155.0	125.0 120.6 120.0	102.0 92.1 96.0

Ordering chart for flow switch Type 8010

Electronic module Type SE10 - for fitting Type S010

Output	Electrical connection	Item no.
Reed contact, NO	Cable plug DIN EN 175301-803	438 087
Reed contact, NC	Cable plug DIN EN 175301-803	438 088

Note: A complete device Type 8010 consists of a fitting Type S010 and an electronic module Type SE10. Please order the two required units separately.

Fitting Type S010 (to be ordered separately)

Port connection	Seal	Standard	Item no.							
			DN 15	DN 20	Range 1		Range 2			
			DN 25	DN 32	DN 40	DN 32	DN 40	DN 50		
Brass - Temperature max. 55°C, PN16										
Internal thread	FKM	G	438 163	438 164	438 165	438 166	438 167	438 169	438 170	438 171
		NPT	438 172	438 173	438 174	438 175	438 176	438 178	438 179	438 180
		Rc (ISO7)	438 181	438 182	438 183	438 184	438 185	438 187	438 188	438 189
External thread	FKM	G	438 190	438 191	438 192	438 193	438 194	438 196	438 197	438 198
Stainless steel - Temperature max. 55°C, PN16										
Internal thread	FKM	G	438 199	438 200	438 201	438 202	438 203	438 205	438 206	438 207
		NPT	438 208	438 209	438 210	438 211	438 212	438 214	438 215	438 216
		Rc (ISO7)	438 217	438 218	438 219	438 220	438 221	438 223	438 224	438 225
External thread	FKM	G	438 226	438 227	438 228	438 229	438 230	438 232	438 233	438 234
Weld ends	FKM	EN ISO 1127/ISO 4200	438 235	438 236	438 237	438 238	438 239	438 241	438 242	438 243
Clamp	FKM	ISO (for pipe EN ISO 1127/ISO4200)	438 244	438 245	438 246	438 247	438 248	438 250	438 251	438 252
Flange	FKM	EN1092-1	438 253	438 254	438 255	438 256	438 257	438 259	438 260	438 261
		ANSI B16-5-1988	438 262	438 263	438 264	438 265	438 266	438 268	438 269	438 270
		JIS 10K	438 271	438 272	438 273	438 274	438 275	438 277	438 278	438 279
PVC - Temperature max. 50°C, PN10										
True union	FKM	DIN 8063	438 091	438 092	438 093	438 094	438 095	438 097	438 098	438 099
		ASTM D 1785/76	438 109	438 110	438 111	438 112	438 113	438 115	438 116	438 117
		JIS K	438 118	438 119	438 120	438 121	438 122	438 124	438 125	438 126
Spigot	FKM	DIN 8063	438 100	438 101	438 102	438 103	438 105	438 106	438 107	438 108
PP - Temperature max. 55°C, PN10										
True union	FKM	DIN 8063	438 127	438 128	438 129	438 130	438 131	438 133	438 134	438 135
Spigot	FKM	DIN 8063	438 136	438 137	438 138	438 139	438 140	438 142	438 143	438 144
PVDF - Temperature max. 55°C, PN10										
True union	FKM	DIN 8063	438 145	438 146	438 147	438 148	438 149	438 151	438 152	438 153
Spigot	FKM	DIN 8063	438 154	438 155	438 156	438 157	438 158	438 160	438 161	438 162

Ordering chart accessories / spare parts (to be ordered separately)

Description	Item no.
O-ring set	
FKM - for metal fitting, DN 15 to 50	426 340
EPDM - for metal fitting, DN 15 to 50	426 341
FKM - for plastic fitting, DN 15	431 555
FKM - for plastic fitting, DN 20	431 556
FKM - for plastic fitting, DN 25	431 557
FKM - for plastic fitting, DN 32	431 558
FKM - for plastic fitting, DN 40	431 559
FKM - for plastic fitting, DN 50	431 560
EPDM - for plastic fitting, DN 15	431 561
EPDM - for plastic fitting, DN 20	431 562
EPDM - for plastic fitting, DN 25	431 563
EPDM - for plastic fitting, DN 32	431 564
EPDM - for plastic fitting, DN 40	431 565
EPDM - for plastic fitting, DN 50	431 566
Sensor holder	
Brass with short blade "range 1", gasket (FKM), screws for DN 15 up to DN 40	560 906
Brass with long blade "range 2", gasket (FKM), screws for DN 32 up to DN 50	561 761

 Further versions on request
**Materials**

Stainless steel sensor holder

To find your nearest Bürkert facility, click on the orange box →

www.burkert.com

In case of special application conditions,
please consult for advice.

Subject to alteration.
© Christian Bürkert GmbH & Co. KG

0912/0_EU-en_00891772